

AN ABSTRACT OF THE DISSERTATION OF

Matthew R. Hallowell for the degree of Doctor of Philosophy in Civil Engineering
presented on March 18, 2008.

Title: A Formal Model for Construction Safety and Health Risk Management

Abstract approved:

John A. Gambatese

Despite recent efforts to improve site safety, construction still accounts for a disproportionate injury and illness rate. According to the 2007 injury and illness data released by the National Safety Council, the construction industry has a fatality and disabling injury rate that is approximately three times higher than the all-industry average. The transient, unique, and complex nature of construction projects makes safety management exceptionally difficult. Most construction safety efforts are applied in an informal fashion under the premise that simply allocating more resources to safety management will improve site safety. Currently, there is no mechanism by which construction site safety professionals may formally select safety program elements for a particular process. This dissertation describes a research effort that introduces, populates, and validates a formal method to evaluate construction safety risk and strategically match safety program elements to construction processes.

The decision scheme introduced, based on the application of Newton's third law, assumes that every construction activity is associated with specific safety risks and that each safety program element is capable of mitigating a portion of such risks. Using the high-risk process of constructing concrete formwork as an example, the theoretical model was populated. Data was obtained using the Delphi method, a systematic and interactive

research technique for obtaining the judgment of a panel of independent experts. The results of this research include the quantification of probability and severity values for ten mutually-exclusive and all-inclusive safety risks associated with thirteen worker-activities required to construct concrete formwork. Additionally, the study quantified the probability and severity reduction values resulting from the implementation of thirteen safety program elements.

The data can be used to improve safety management techniques in several ways. First, cumulative risk may be tracked throughout a work period allowing safety managers to identify and avoid periods of exceptionally high safety risk. Second, safety managers may strategically select safety program elements based on the ability to reduce portions of specific risks. Finally, the balance between cumulative risk and the safety mitigation can be evaluated.

The results of this research indicate that the highest risk activities for formwork construction are form lubrication and preparation, ascending and descending ladders, and accepting and loading materials with a crane. The most effective safety program elements are upper management support and commitment, subcontractor selection and management, and employee involvement in safety management and planning. The risk values for formwork construction and the risk reduction values associated with safety program elements can be used to determine the appropriate scope and focus of safety and health management efforts. The methods used to quantify these values may be applied to any construction process or safety program.

© Copyright by Matthew R. Hallowell

March 18, 2008

All Rights Reserved

A Formal Model for Construction Safety and Health Risk Management

by

Matthew R. Hallowell

A DISSERTATION

submitted to

Oregon State University

in partial fulfillment of

the requirements for the

degree of

Doctor of Philosophy

Presented March 18, 2008

Commencement June 2008

UMI Number: 3321087

Copyright 2008 by
Hallowell, Matthew R.

All rights reserved

INFORMATION TO USERS

The quality of this reproduction is dependent upon the quality of the copy submitted. Broken or indistinct print, colored or poor quality illustrations and photographs, print bleed-through, substandard margins, and improper alignment can adversely affect reproduction.

In the unlikely event that the author did not send a complete manuscript and there are missing pages, these will be noted. Also, if unauthorized copyright material had to be removed, a note will indicate the deletion.

The logo for UMI (University Microfilms International) consists of the letters "UMI" in a bold, serif font, with a registered trademark symbol (®) to the upper right of the "I".

UMI Microform 3321087
Copyright 2008 by ProQuest LLC
All rights reserved. This microform edition is protected against
unauthorized copying under Title 17, United States Code.

ProQuest LLC
789 East Eisenhower Parkway
P.O. Box 1346
Ann Arbor, MI 48106-1346

Doctor of Philosophy dissertation of Matthew R. Hallowell presented on March 18, 2008

APPROVED:

Major Professor, representing Civil Engineering

Head of the School of Civil and Construction Engineering

Dean of the Graduate School

I understand that my dissertation will become part of the permanent collection of Oregon State University libraries. My signature below authorizes release of my dissertation to any reader upon request.

Matthew R. Hallowell, Author

ACKNOWLEDGEMENTS

The faculty of the School of Civil and Construction Engineering has provided me with tremendous graduate school experience: they have taught me how to think; they have provided me with research and teaching opportunities; and they have shown me how to integrate creativity into all of my work. Several individuals deserve special mention for their contributions to this dissertation and my development.

John Gambatese has been what I can only describe as the ideal advisor. He played an instrumental role in my decision to attend Oregon State University, supported me with research and teaching assistantships, provided continuous guidance during every phase of my doctoral program, and is a great friend. My favorite memories of graduate school are the times in John's office simply talking through ideas in a relaxed and enjoyable environment. After three years of working closely with John, I have never seen him in any condition other than calm, cool, and collected. He will be my role model as I continue in academia.

Although he was not part of my dissertation committee, Mike Toole has also played a primary role in my development. Mike's candid comments, attention to detail, and superior intellect are inspiring traits in a colleague and his generosity, kindness, and supportive nature make him the best of friends. He has always taken the time to introduce me to people within our discipline, shown faith in my work, and has been my best advocate. My success as a graduate student is largely the result of his influence and support. Mike will always be a close colleague and friend.

Upon arriving to OSU, I began a minor in Public Health with few expectations. Anthony Veltri, my minor advisor, was a most pleasant surprise. Anthony was a great instructor but it wasn't until after our independent study, multiple trips to Seattle, watching football, and laughing over lunch that I could fully appreciate Anthony's personality. He is funny, strong-willed, intelligent, and caring. He is generous with his time, has provided me with every opportunity, and has taken great care in his advice. I feel that I have made a life-long friend and mentor.

David Sillars, more than anyone else, taught me patience and critical-thinking skills. By following his example, I have come to learn that it is always appropriate to take a moment to think your ideas through, ponder alternatives, and justify your decisions. I also share in his distaste for veggie burgers.

David Rogge was my first research advisor at OSU. He had great faith in my ability and gave me my first opportunity to shape research, analyze data, and write results. He was always patient and willing to provide guidance. My favorite thing about him: He always greeted me with a smile.

Without my friends, I never would have made it this far. I have enjoyed great trips, races, work-out sessions, and parties with the most interesting people. Fortunately, there are too many to name here. Thank you all for keeping me sane.

I don't believe that one can truly do their family justice in acknowledgements, so I'll leave it at this: my parents, grandparents, aunts, and uncles all deserve recognition for their support, guidance, and exceptional character. I am fortunate to be a product of a close-knit family that enjoys each other's company with no exceptions. I love you all from the bottom of my heart.

Special thanks to Alexis Will. Her love, support, and friendship have enhanced my life tremendously. She is the most important person in my life and I am lucky to have her by my side.

TABLE OF CONTENTS

	<u>Page</u>
Introduction	1
0.1. Dissertation Structure	2
0.2. Primary Research Objectives	3
0.3. Key Terms	6
Manuscript 1 – Current Industry Practice and model Theory	11
1.1. Preface	11
1.2. Introduction	11
1.3. The Importance of Construction Safety Research	12
1.4. Accident Causation and Analytic Models	20
1.5. Current Safety and Health Management Strategies	31
1.6. Safety Equilibrium Model	36
1.7. Conclusion	45
Manuscript 2 – Safety Risk Demand for the Construction of Concrete Formwork	47
2.1. Preface	47
2.2. Introduction	48
2.3. Literature Review	51
2.4. Methodology	64
2.5. Results	99
2.6. Analysis	117
2.7. Application	126
2.8. Conclusions	134

	<u>Page</u>
Manuscript 3 – Risk Mitigation Capacity of Essential Construction	
Safety and Health Program Elements	137
3.1. Preface	137
3.2. Introduction	137
3.3. Literature Review	140
3.4. Methodology	152
3.5. Results	156
3.6. Analysis	166
3.7. Application	174
3.8. Conclusions	176
Manuscript 4 – Population and Validation of a Formal Model for	
Construction Safety and Health Management	178
4.1. Preface	178
4.2. Introduction	178
4.3. Application of the Equilibrium Concept	182
4.4. Literature Review	188
4.5. Methodology	190
4.6. Results	198
4.7. Conclusions	221
4.8. Discussions	223
Conclusions, Limitations, and Recommendations	225
5.1. Introduction	225
5.2. Conclusions	225
5.3. Overarching Conclusions and Applications	235

	<u>Page</u>
5.4. Limitations	236
5.5. Recommendations for Future Research	241
Bibliography	244
Appendix	254

LIST OF FIGURES

	<u>Page</u>
1.1. Annual fatality rate of the construction industry compared to the all-industry average	13
1.2. Annual disabling injury rate of the construction industry compared to all industry	14
1.3. Traditional Design-Bid-Build model	17
1.4. The two-factor model	23
1.5. Reason's Accident Trajectory Model	24
1.6. Marcum and Veltri's Analytic Model	28
1.7. Accident causation model	30
1.8. Safety risk demand	41
1.9. Safety risk mitigation	44
1.10. Safety Equilibrium Model	45
2.1. Safety risk demand	49
2.2. Causes of high-severity formwork accidents	62
2.3. Typical events during the Delphi process	72

	<u>Page</u>
2.4. Relationships between group-data collection techniques	76
2.5. Applicability of the Delphi method for this research	79
2.6. Fatality-disabling injury cost ratio from 1998 to 2007	96
2.7. Comparison of injury severity levels	98
2.8. Schedule-based safety risk plot (original)	131
2.9. Schedule-based safety risk plot (leveled)	133
3.1. Safety risk mitigation	139
3.2. Sustainable Construction Safety and Health Rating System	151
3.3. Most effective safety program elements	172
3.4. Cost effectiveness example	175
4.1. Safety equilibrium model	181
4.2. Safety risk demand v. safety risk perception	208
5.1. Safety equilibrium model	229

LIST OF TABLES

	<u>Page</u>
1.1. Costs associated with disabling injuries and fatalities in the construction industry	15
1.2. Typical work conditions in construction and manufacturing	18
1.3. Expert qualification	34
1.4. Methods of selecting safety program elements	35
2.1. Construction safety risk classifications	57
2.2. Support for the Delphi method as a viable research technique	73
2.3. Criticism of the Delphi method as a research technique	74
2.4. Controls for bias in the Delphi process	91
2.5. Proposed probability scale	94
2.6. Dollar values associated with injury severity levels	97
2.7. Adjusted severity scales	99
2.8. Industry survey demographics	102
2.9. Delphi demand panel expert characteristics	109

	<u>Page</u>
2.10. Probability ratings obtained through the Delphi process	112
2.11. Severity ratings obtained through the Delphi process	113
2.12. Probability conversions	119
2.13. Probability ratings (incidents per worker-hour)	120
2.14 . Adjusted severity values	121
2.15 . Risk scores (severity per worker-hour)	123
2.16. Comparison of risk values among safety risk classification codes	124
2.17. Comparison of risk values among formwork construction activities	125
2.18. Risk tracking for a hypothetical workday (original)	130
2.19. Risk tracking for a hypothetical workday (leveled)	132
3.1. Objectives and abilities of safety elements	142
3.2. Essential safety program elements	145
3.4. Probability mitigation scale	155
3.5. Severity mitigation scale	155
3.6. Delphi capacity panel expert characteristics	158

	<u>Page</u>
3.7. Probability reduction ratings obtained through the Delphi process	161
3.8. Severity reduction ratings obtained through the Delphi process	162
3.9. Probability conversions	167
3.10. Probability reduction ratings	168
3.11. Risk mitigation scores	170
3.12. Risk mitigation values	172
3.13. Risk mitigation due to the implementation of all 13 elements	173
3.14. Example effectiveness ratings	175
4.1. Original probability, severity, and risk	185
4.2. Reduction in probability and severity	186
4.3. Resulting risk values	187
4.4. Comparison of original risk and resulting risk	188
4.5. Worker-hour equivalents for recognizable time periods	196
4.6. Duration of worker activities for Crew 1 (Elevated slab)	201
4.7. Duration of worker activities for Crew 2 (Wall)	202

	<u>Page</u>
4.8. Cumulative risk for Crew 1 (Elevated slab)	203
4.9. Cumulative risk for Crew 2 (Wall)	204
4.10. Risk perceptions of Crew 1 (Elevated slab)	206
4.11. Risk perceptions of Crew 2 (Wall)	207
4.12. Delphi demand panel expert characteristics	210
4.13. Results of the Delphi process (all rounds)	213
4.14. Comparison of validation results (conflicting elements omitted)	214
4.15. Comparison of capacity values and validation results	215
4.16. Worker-hours per activity	217
4.17. Resulting risk demand	218
4.18. Risk perceptions	220
4.19. Risk perceptions	220

LIST OF APPENDICIES

	<u>Page</u>
Appendix A – Introductory Delphi survey	255
Appendix B – Expert review of formwork activities	259
Appendix C –Round 1 Delphi survey of demand panel (complete)	265
Appendix D – Round 2 Delphi survey of demand panel (partial)	281
Appendix E – Round 3 Delphi survey of demand panel (partial)	284
Appendix F – Round 1 Delphi survey of capacity panel (complete)	288
Appendix G – Round 2 Delphi survey of capacity panel (partial)	304
Appendix H – Round 3 Delphi survey of capacity panel (partial)	307
Appendix I – Round 1 Delphi survey of validation panel (complete)	310
Appendix J – Risk perception survey	314
Appendix K – Incident data form	316
Appendix L – Expected activities form	317
Appendix M – Survey of safety program elements implemented	318

INTRODUCTION

Matthew R. Hallowell

Despite recent efforts to improve site safety, construction still accounts for a disproportionate injury and illness rate. According to the 2007 injury and illness data released by the National Safety Council, the construction industry has a fatality and disabling injury rate that is approximately three times higher than the all-industry average. The transient, unique, and complex nature of construction projects makes safety management exceptionally difficult. Most construction safety efforts are applied in an informal fashion under the premise that simply allocating more resources to safety management will improve site safety. While some construction firms are capable of implementing a large proportion of applicable safety program elements, a vast majority of firms must operate under a limited budget and are forced to select a small subset of elements. Currently, there is no mechanism by which construction site safety professionals can formally select safety program elements for a particular process.

The primary objective of this dissertation is to create a formal method of construction safety risk management that can be used to evaluate the relative effectiveness of safety program elements based upon the activities expected for a given process. Other objectives include determining the probabilities and severities for the worker activities associated with a selected construction process, and defining the probability and/or severity reduction values resulting from the implementation of various safety program elements.

In this dissertation, a theoretical model is created, expected risk values associated with a construction processes will be defined, the risk mitigation resulting from the implementation of various safety program elements is quantified, and the data is

combined to create a data-driven model for construction safety and health risk management. Ideally, this model will be implemented in practice to improve construction site safety.

This dissertation is divided into four, independent manuscripts. These manuscripts are intended for independent submission to scholarly journals. The structure of this dissertation, and the specific topics covered in each manuscript, are described below.

0.1. DISSERTATION STRUCTURE

Each manuscript covers one major theme and builds upon previous results. While each manuscript stands alone in its own right, there is significant reference to topics, data, and strategies described in previous manuscripts. Repetition has been avoided in most manuscripts. However, some topics are revisited when necessary to provide appropriate context.

0.1.1. Manuscript 1

The first manuscript, entitled “Current Industry Practice and Model Theory,” includes a discussion of the importance of construction safety research, a review of several safety and health analytic models, investigation of current safety and health management practices in construction, and the introduction of a formal risk-based model for construction safety management.

0.1.2. Manuscript 2

The second manuscript, entitled “Safety Risk Demand for the Construction of Concrete Formwork,” reviews the current safety risk quantification techniques and populates the demand portion of the theoretical model introduced in the first manuscript. Quantifying risk demand involves the identification of the activities required to construct concrete formwork (the highlighted construction process), identification and classification of

construction safety risks, and quantification of the probability and severity levels for risks associated with each activity.

0.1.3. Manuscript 3

The third manuscript, entitled “Safety Risk Mitigation Resulting from the Implementation of Construction Safety Program Elements,” reviews literature that identifies the most effective safety program elements and quantifies the probability and/or severity reduction resulting from the implementation of selected safety program elements.

0.1.4. Manuscript 4

The fourth and final manuscript entitled, “Population and Validation of a Formal Model for Construction Safety and Health Risk Management,” presents the fully-populated equilibrium model and suggests several applications. Also included in this manuscript is a description of a detailed research effort aimed at validating the two central components of the model: demand and capacity. A combination of project data and perception surveys is used to validate the risk data collected in previous manuscripts and the Delphi method is used to confirm the relative effectiveness of the selected safety program elements.

0.2. PRIMARY RESEARCH OBJECTIVES

The purpose of this dissertation is to make six significant and original contributions to the fields of construction safety and risk management. Additionally, this dissertation attempts to make three minor contributions. Each research objective involves answering a major research question. These questions are highlighted at the end of this section. A review of each primary research objective is summarized below.

0.2.1. Creation of a theoretical model for formal management of construction safety and health risk

As indicated, the construction industry lacks a formal method of evaluating existing safety risk and appropriate risk reduction techniques. The present research aims to create a formal method for managing construction safety and health risk. This management model, based upon the application of Newton's third law, is introduced and described in detail in the first manuscript.

0.2.2. Activity-based quantification of safety risks for a particular process

Many studies aim to quantify construction safety risks. Most studies, however, use subjective risk ratings such as the Likert (i.e., 1-5) scale. Studies also attempt to use actual probability and severity values from archived data published by the Bureau of Labor Statistics (BLS). These studies only focus on high severity, low probability incidents. The present study attempts to quantify construction safety risks for particular worker activities for a given process using a full spectrum of potential severity types.

0.2.3. Quantification of risk mitigation resulting from the implementation of safety program elements

No study reviewed by the author makes an attempt to quantify safety risk mitigation. The research effort described in the third manuscript attempts to make such a contribution. This objective is achieved by quantifying the probability and/or severity reduction resulting from the independent implementation of selected safety program elements. Defining such safety risk mitigation values is unprecedented.

0.2.4. Population of the theoretical equilibrium model

Merging the concepts of demand and capacity and evaluating resulting risk (i.e., degree of equilibrium) represents a significant contribution made by this dissertation. The specific methodology used to identify original risk values, risk mitigation values, and

resulting risk involves populating and implementing the theoretical model introduced in the first manuscript.

0.2.5. Validation of results

In addition to obtaining original data, this dissertation also aims to validate all major results. The final manuscript summarizes research that validates the safety risk values for a given process, the risk mitigation resulting from the implementation of safety program elements, and the concept of equilibrium.

0.2.6. Minor Objectives

In route to achieving the primary objectives, this research also involves several minor contributions. These minor contributions also represent secondary research objectives.

0.2.6.1. Identification of current methods of construction safety and health risk management

This minor research objective involves the identification of the current methods of safety risk management. The structure and limitations of these methods are highlighted in the first manuscript.

0.2.6.2. Creation of probability and severity scales

As described in the second manuscript, expert panelists were asked to rate the probability and severity associated with the construction of concrete formwork. In order to facilitate these ratings, probability and severity scales that encompass all types of risks had to be created. Most scales developed prior to this study are very simple and subjective. The scales developed for this study include actual probability and severity ratings for all types of accidents ranging from near misses to fatalities.

The research objectives discussed above can be restated in terms of research questions. These research questions are presented below, in the order in which they are addressed in this dissertation:

1. What are the current methods of construction safety risk management?
2. Can a theoretical model for construction safety risk management be created using current risk management theory?
3. What are the risk values associated with the process of constructing concrete formwork?
4. Can probability and severity scales be created that encompass all potential probability and severity levels?
5. What is the risk mitigation that results from the independent implementation of safety program elements?
6. Can the risk demand and risk capacity values be combined in the manner suggested by the theoretical equilibrium model developed?
7. Can the results of this dissertation be validated using alternate research techniques?

0.3. KEY TERMS

This section provides definitions of many key terms that are essential to this dissertation. These terms occur frequently throughout the dissertation and may be used in a variety of contexts. Furthermore, many of these terms are used interchangeably in informal conversation because the differences between the terms may be subtle. It is important for the reader to understand these subtle differences. A full understanding of the key terms is necessary to fully-comprehend the structure, methodology, results, and application of this document.

0.3.1. Accident

According to Webster's Dictionary (2007), the word accident refers to an event that occurs by chance without an apparent cause. Since the causes of construction accidents are typically well-known, the use of the word "accident" will be avoided.

0.3.2. Capacity

Capacity is defined as the risk mitigation resulting from the implementation of safety program elements. Capacity is calculated by multiplying the ability of a comprehensive program or program element to reduce the probability of an incident by the ability to reduce the severity of the incident. Capacity may be defined for individual program elements or may be expressed by the sum of the mitigation ability (i.e., individual capacities) of all selected safety program elements. When discussing capacity a clarifier that defines the type of capacity (e.g., individual element, entire program) must be included.

0.3.3. Cumulative Risk

Cumulative risk is defined as the collective risk demand associated with an activity, process, or project. Cumulative risk involves the inclusion of exposure (e.g., number of worker-hours spent on an activity). The unit of cumulative risk is equal to those defined by severity. For example, if severity is measured in dollars, cumulative risk is expressed in dollars. Cumulative risk may be defined for one activity or for the collective activities in a process or project. When discussing cumulative risk, a clarifier (e.g., cumulative risk for a static lift, cumulative risk for constructing concrete formwork) that indicates the scope of risk must be included.

0.3.4. Demand

For this study demand refers to the risk associated with a work activity, process, or project. Demand may be defined in terms of the individual activity risk, process risk, or

project risk and must, therefore, include a clarifier that describes the types of risk included.

0.3.5. Hazard

A hazard is the source of danger that may result in loss. Hazard is different from risk in that a hazard describes a condition whereas risk describes a potential event. For example, the condition of working at height is a hazard, while a fall from height and sustaining an injury is classified as a risk.

0.3.6. Incident

An incident is a distinct event. In the context of risk, an incident is the realization of a potential event. The word incident often carries a negative connotation. An incident is different from a risk in that an incident is the realization of a potential event while a risk includes both the element of chance and a potential magnitude of severity.

0.3.7. Equilibrium

Equilibrium is defined as a stable situation in which the net force is equal to zero. In structural engineering, equilibrium occurs when forces are balanced (e.g., the force on a beam is equal to the capacity of the beam). In terms of risk, equilibrium occurs when the demand is equal to the capacity. Equilibrium can also be described in terms of resulting risk.

0.3.8. Exposure

Exposure refers to the duration of contact with a hazardous situation (e.g., days). Exposure is used to convert a unit risk (e.g., dollars per day) to a cumulative risk (e.g., dollars).

0.3.9. Frequency

Frequency is a measurement of the number of occurrences of an event in a given time period. In terms of construction risk, frequencies (e.g., events per worker-hour) may be converted into probabilities when defined in a particular context (e.g., events per worker per hour). Frequency is defined as a rate where probability is a dimensionless measure of chance.

0.3.10. Opportunity

Opportunity is a potential event that may result in a preferred outcome.

0.3.11. Probability

Probability provides a quantitative description of the likely occurrence of a particular event. Probability is conventionally expressed on a scale from 0 to 1; a rare event has a probability close to 0, a very common event has a probability close to 1. When discussing risk, probability must be defined in a particular context such as the probability that an event will happen to one worker in a one-hour work period.

0.3.12. Risk

Risk is a potential event that results in an outcome that is different from what is planned. Risk is characterized by the simultaneous presence of an element of chance and a magnitude of impact. The term risk implies the potential for a *negative* outcome.

0.3.13. Severity

Severity defines the degree of magnitude associated with an incident. In terms of risk, severity describes the outcome of an incident. For an incident that results in injury, the units of severity may include, but are not limited to, dollars, time away from work, and subjective measures of human impact.

0.3.14. Unit Risk

Unit risk is the risk per unit of exposure. An example of unit risk is dollars per worker-hour. Unit risk is calculated by multiplying the probability of an event (i.e., incidents/exposure) by the severity (i.e., magnitude). Cumulative risk for an activity is calculated by multiplying unit risk by actual exposure.

MANUSCRIPT 1.0
CURRENT INDUSTRY PRACTICE AND MODEL THEORY
Matthew R. Hallowell

1.1. PREFACE

The main objectives of this manuscript are to illustrate the importance of construction safety research, review safety and health analytic models, identify current safety and health management practices in construction, and present a formal risk-based model for construction safety management. In other words, this manuscript demonstrates the need for a new safety risk management technique, indicates where a new model would fit within the context of current practice, and briefly describes the framework of a proposed risk-based model. The theoretical model proposed in this manuscript contains three key concepts: risk demand, risk capacity, and equilibrium. These three concepts are introduced in this manuscript and are the foci of manuscripts one, two, and three, respectively. The result of this research is a fully-populated and validated version of the theoretical model introduced and justified in this manuscript.

1.2. INTRODUCTION

This manuscript is divided into four core sections: the importance of construction safety research, discussion of safety and health analytic models, identification of the current safety and health management practices in construction, and the introduction of a risk-based construction safety management model. The author believes that these sections contain sufficient detail to provide the reader with an understanding of the importance of safety research, the limitations of the current safety and health management techniques and analytic models, and the need for a formal, risk-based analytic model.

1.3. THE IMPORTANCE OF CONSTRUCTION SAFETY RESEARCH

1.3.1. Disproportionate injury and illness rates

It is no secret that the construction industry is responsible for a relatively high occupational injury rate. According to the Bureau of Labor Statistics (BLS 2007), the construction industry, the largest single-service industry in the United States, consistently employs approximately five percent of the American workforce. Data assembled from the National Safety Council (NSC 2003) indicates that construction accounts for approximately twelve percent of the United States' occupational fatalities and consistently has the third highest fatality rate of all US industries. In fact, nearly 10 of every 100,000 workers are fatally injured while employed on a construction site. Figure 1.1 presents a graphical representation of the fatality data from 1952 to 2003. As one can clearly see, the construction industry accounts for a disproportionate fatality rate that is nearly three times higher than that of general industry.

Figure 1.2 illustrates the disabling injury rates of the US construction industry compared with the all-industry average from 1951 to 2004 (NSC 2006). While both fatality and disabling injury rates have declined in the time period shown, the construction industry still accounts for a highly disproportionate injury and fatality rate. Therefore, focused research in construction safety and health management is warranted.

International studies have shown similar evidence that construction safety is an important issue that deserves attention. For example, researchers in the United Kingdom (UK) have found that construction workers in the UK are five times more likely to be killed and two times more likely to suffer a serious injury than the all-industry average (Carter and Smith 2006). Specifically, the fatality rate in 1998 in the UK was 5.6 fatalities per 100,000 workers and, during the same year, the average fatality rate in construction for the European Union as a whole was over 13 fatalities per 100,000 workers (Carter and Smith 2006).

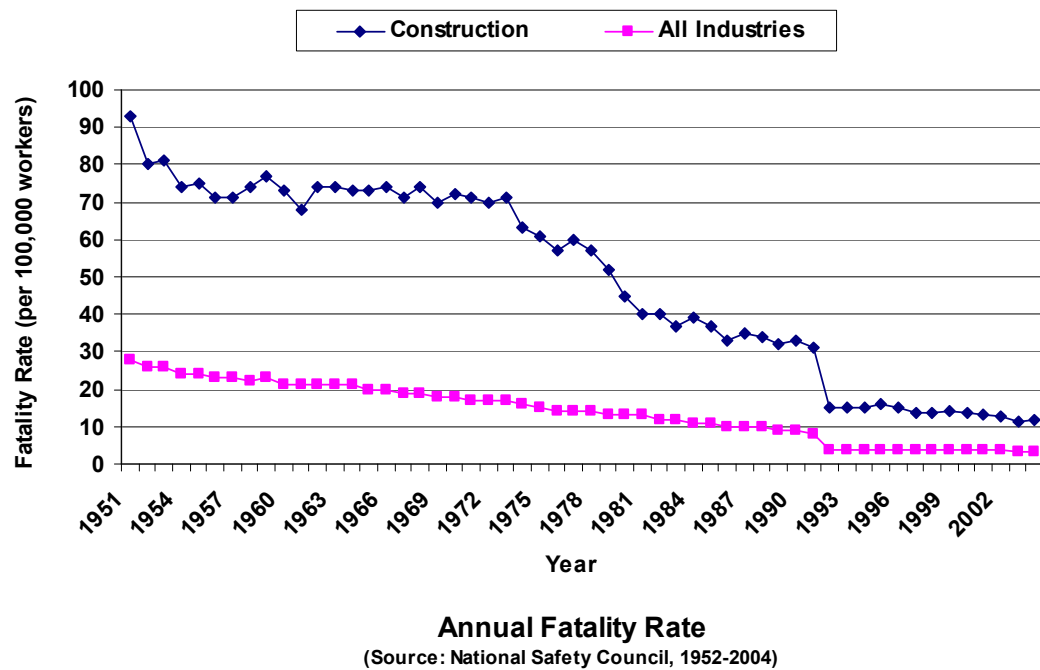

Figure 1.1 – Annual fatality rate of the construction industry compared to the all-industry average¹

In recent years, safety performance has become a more recognized issue in the construction industry for a variety of reasons including the results of studies which have shown that hazardous work environments may have a significant impact on schedule and budget performance.

¹ One may note a sudden decrease in 1992. This sharp decrease in fatality rate reflects a change in the data collection procedure adopted by the National Safety Council (NSC).

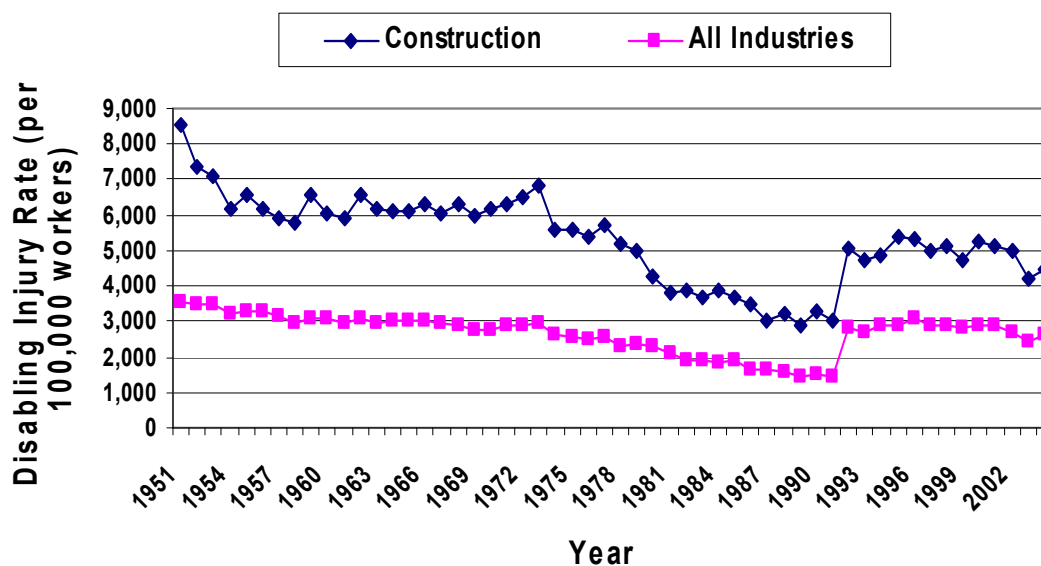

Figure 1.2 – Annual disabling injury rate of the construction industry compared to all industry²

1.3.2. High Cost of Construction Accidents

Hinze et al. (2006) observed that construction safety has gained attention because of the increasing workers' compensation insurance premiums that have resulted from a great increase in medical costs and convalescent care. In 2004, the construction industry experienced 460,000 disabling injuries and the cost of these disabling injuries was estimated to be \$15.64 billion (NSC 2006). The NSC also estimates that there were 1,194 fatalities in 1994, and the average cost of each of these fatalities (to the employer) was approximately \$1,150,000. With just under 10.3 million individuals employed in the construction industry, the average total cost for disabling injuries and deaths can be calculated to be \$1,656 per construction employee. Table 1.1 outlines the estimated cost of disabling injuries and deaths in the construction industry.

² One may note a sudden spike in 1992. This sharp increase in disabling injury rate reflects a change in the data collection procedure adopted by the National Safety Council (NSC).

While the costs presented in Table 1.1 are relatively high, these figures do not include the high-probability, low-severity incidents that may lead to a significant proportion of occupational safety and health-related costs. Furthermore, the NSC figures do not account for all indirect costs. According to literature such as Hinze (1997), indirect costs may represent over half of the true cost of construction accidents. Therefore, the true cost of construction safety incidents may be even more compelling than the figures calculated from the NSC data above.

Table 1.1 – Costs associated with disabling injuries and fatalities in the construction industry (NSC 2006, as cited in Rajendran (2006))

	Number in 2004	Cost per fatality/injury	Total cost
Fatalities	1,194	\$ 1,150,000	\$ 1,373,100,000
Disabling injuries	460,000	\$ 34,000	\$ 15,640,000,000
Total Cost			\$ 17,013,100,000
Construction workers	10,272,000		
Total cost per employee			\$ 1,656

1.3.3. Inherent characteristics of the construction industry that influence construction safety

This section describes several of the inherent characteristics of the construction industry that significantly impact construction safety performance as defined by literature. While many of the relationships between characteristics and safety performance are not supported by empirical evidence, the literature is based upon sound theory and many years of observation.

The construction industry has a variety of unique features that distinguishes it from manufacturing, service, agriculture, and all other industries. Construction is commonly defined as the industry that is responsible for building or assembling infrastructure or buildings on a given site. This section aims to uncover some of the unique attributes of

the construction industry and discuss their impact on construction safety. Furthermore, the construction industry is compared to manufacturing, another large-scale US industry. The intent of this section is to help the reader to understand many of the characteristics that make safety and health management in construction exceptionally complex.

Fredricks, Abduayyeh et al. (2005) contend that construction injuries are common because of many of the inherent characteristics of the construction industry including dynamic work environments, industry fragmentation, multiplicity of operations, proximity of multiple crews, and industry culture. Each of these characteristics contributes to unforeseen and unfamiliar hazards or the unsafe behavior of workers. Each of these factors is discussed below.

1.3.3.1. Fragmentation

Perhaps the most unique feature of the construction industry is the fragmentation of the project phases in design-bid-build (DBB) project delivery method. For the past half-century, the dominant design and construction process for buildings has been understood as a three-step process: Architects and engineers (AEs) design the project, bids are solicited from contractors, and contractors construct the project (Mehta et al. 2006). The process has traditionally been viewed as being linear and compartmentalized. Specifically, engineering design is completed by AEs before construction begins, and contractors merely implement the AEs' designs. Under this project delivery model, general contractors and subcontractors only provide construction services, and material vendors only manufacture and deliver product to the site (Tatum 2000). Figure 1.3 represents the model of design-bid-build project delivery.

Alternatively, the manufacturing industry operates under a much different product delivery model. In most manufacturing firms the owner, designer, and constructor are all employed by the same firm. That is, a manufacturing firm typically controls all operations that bring a product from conception to completion (McCrary, Smith et al.

2006). This is true with the exception of suppliers, in which case many large firms still exhibit significant control.

The significant difference in industry structure is likely to explain some of the variation in safety performance. In manufacturing, each business unit (e.g. design, operations, safety and health) works toward the common goals set by upper management. While there is likely to be conflict between these organizational functions, priority can be set by management. In construction, however, relationships between firms can be adversarial and the priorities of one firm may conflict with another. Additionally, this structure limits the ability to provide construction input into the design of the final facility.

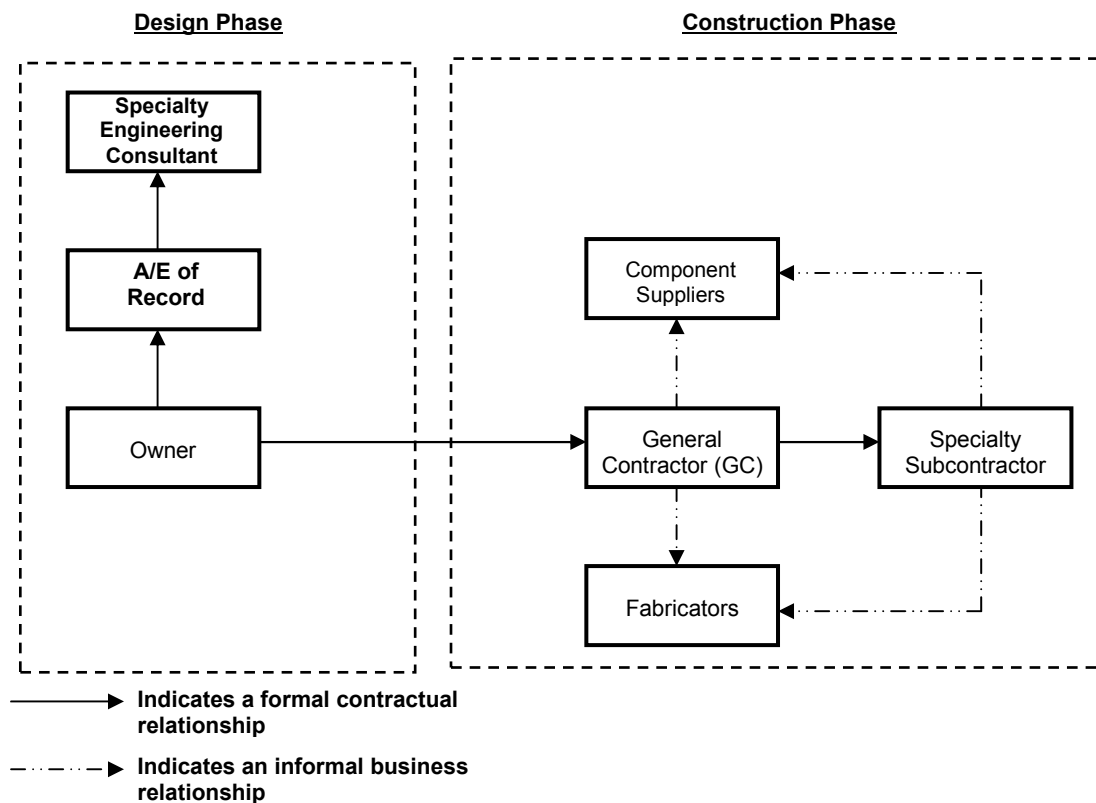

Figure 1.3 – Traditional Design-Bid-Build Model

One should note that contemporary contracting methods such as design-build and CM/GC are becoming more prevalent in the construction industry. These integrated delivery methods more closely resemble the organizational structure of a manufacturing firm. In these two delivery methods, the designers and the constructors work together early in the design phase of the project. It is not surprising that these integrated delivery methods are associated with lower incident rates in comparison to DBB (Gamabtese 2006). However, even when the project phases are integrated, several factors continue to make construction particularly dangerous.

1.3.3.2. *Dynamic work environments*

Construction, unlike manufacturing, is unique, transient, and dynamic in nature. That is, construction project site conditions are constantly changing, exposed to stochastic elements, and differ significantly from previous projects. In industries like manufacturing, the work conditions are relatively stable. As shown in Table 1.2, the construction industry is relatively dynamic with high levels of uncertainty. While this table provides only general statements and is not comprehensive, it provides the reader with several factors that may contribute to the relatively high fatality rates in construction. The characteristics listed in Table 1.2 are supported by a great deal of literature including Hinze (1997), Hinze and Wilson (2000), Carter and Smith (2006), and Yi and Langford (2006). Most importantly, in construction, work tasks are often unpredictable, worker crews are constantly changing, and the work conditions distract workers from safely completing tasks.

Table 1.2 – Typical work conditions in construction and manufacturing

Work Condition	Construction	Manufacturing
Shelter	Often little or none	Work occurs inside
Repetition	Low	High
Task Predictability	Low	High
Task Standardization	Low	High
Work-hours	Various	Controlled shifts

1.3.3.3. *Culture*

Another factor that may contribute to the disproportionate disabling injury and fatality rates is a negative safety culture on construction sites. Three cultural factors are: macho attitudes, substance abuse, and language barriers.

1.3.3.3.1. *Machismo*

Traditionally, the construction industry has been viewed as a ‘tough’ industry. Many workers pride themselves in being burly and capable of performing work without worrying about safety (Hinze 1997). This attitude is likely to increase the risk tolerance and, therefore, the frequency and severity of injuries.

1.3.3.3.2. *Substance abuse*

According to Gerber and Yacoubian (2001), the U.S. Department of Health and Human Services found that the construction industry had nearly double the rate of employees abusing alcohol or using illicit drugs when compared to the all-industry average. The use of drugs and alcohol in one’s personal life can have significant impacts on one’s ability to work safely. Substance abuse results in reduced reaction time, compromised judgment and many other negative effects (Hill 2004). When substances are abused in the workplace, and workers are performing duties while under the influence, the negative effects are magnified substantially. The fact that the construction industry was found to have an extraordinarily high substance abuse rate is alarming considering construction involves heavy machinery, complex crews, and potential danger to the public.

1.3.3.3.3. *Language barriers*

Finally, language barriers have been identified as a causal factor for construction incidents, especially in the South-Western States in the US where a relatively high proportion of the workforce is Spanish-speaking (Hill 2004). Unfortunately, on many of

these sites the safety manager and other members of management do not speak Spanish. Therefore, it is difficult for these individuals to warn Spanish-speaking workers of potential hazards. This is especially true when Spanish-speaking workers pretend to understand directions in fear of losing their jobs. Language barriers present in the U.S. construction industry are yet another cultural factor that limit safety and health performance.

Data and sound safety and health theory have provided compelling evidence that construction safety research is vital to the success of projects and the well-being of the workers. This dissertation aims to introduce, populate, and validate a new, risk-based, safety and health analytic model that can be used to evaluate expected risk on construction sites and aid in safety and health decision-making. The model presented later in this manuscript is the result of extensive literature review, integration of the concept of equilibrium, sound risk management theory, and the application of existing analytic models. The concept of equilibrium will be discussed in detail in Section 1.6, and risk management theory will be discussed throughout this manuscript and the following three manuscripts.

1.4. ACCIDENT CAUSATION AND ANALYTIC MODELS

Before presenting the theoretical model, it is necessary to review the current safety and health models that guide our understanding of incidents and indirectly guide decision-making and management techniques. The most influential and highly regarded safety and health analytic models are presented in this section. While some of the models have been developed for industries other than construction, their concepts and theories extend to the construction industry as well. This section is necessary to provide the reader with an understanding of the need for a new model and to illustrate where the proposed model fits within existing literature.

Following the Occupational Health and Safety Act of 1970, employers became increasingly concerned with workplace safety. The OSH Act essentially shifted the responsibility of worker safety and health from the workers themselves to the employer. Therefore, employers became more concerned with the mechanisms by which safety incidents occur. Subsequently, researchers began evaluating safety and health incidents and studying the factors that influence safety performance. The results of these research efforts involved the creation of an analytic model that depicts the factors that lead to an injury.

The objective of this section is to provide an overview of five analytical accident sequence models. These five models are presented in order of complexity. First, the most basic model, that suggests that injuries are the direct result of two primary factors, is presented. This model is followed by a simple, but effective model that describes the chain of events that must exist for an injury to occur. These two analytic models, first published in the 1950's, have been cited in countless publications and presentations. These models also serve as the foundation upon which three advanced analytic models that have been formulated. The three advanced models, developed in the latter half of the twentieth century, include Reason's accident trajectory model (Reason 1990), Everett Marcum and Anthony Veltri's risk, danger, and loss analytic model (Veltri 2006), and a systems model of construction accident causation developed by Mitropoulis, Abdelhamid, et al. (2005). While there are many methods and models for analyzing safety and health incidents, these well-known models are highlighted in this paper because of their recognition and application to the construction industry.

1.4.1. Two-factor model

Most contemporary literature agrees that incidents are the direct result of two factors: uncontrolled hazardous exposure and unsafe worker actions (Heinrich 1959; Reason 1990; Hinze 1997; Gibb, Haslam et al. 2004). Traditional research primarily focused on the latter, claiming that every incident was the sole responsibility of the worker.

However, the two-factor model, introduced by Heinrich (1959), suggests that incidents result from a combination of the two factors. In some cases, one factor may contribute more than another. Nevertheless, both causal factors must be present for an accident to occur.

This simple model serves as the foundation of an effective safety and health management program. Construction safety programs are typically designed to reduce (or eliminate) uncontrolled hazardous exposure or unsafe worker actions. In the case where uncontrollable hazardous exposures are unavoidable, safety programs must ensure that workers are trained to recognize and avoid contact. Many research studies in construction safety support the negative correlation between safety program implementation and incident rate reduction (King and Hudson 1985; Peyton and Rubio 1991; Hislop 1999).

The two-factor model is illustrated in detail in Figure 1.4. This figure has been adapted from Reason (1990). It is apparent from this model that incidents are the direct result of two factors: unsafe conditions and unsafe actions. Examining the figure in greater detail reveals the secondary factors that cause unsafe conditions and contribute to unsafe behaviors. These secondary factors will not be discussed in detail here. The author refers the reader to, “Human Error” by James Reason. This book contains a well-written and detailed description of all of the forces illustrated in Figure 1.4.

Following this model, the U.S. Navy created a more advanced version that suggests that incidents are the result of a chain of events, each contributing to an unsafe action or an unsafe condition.

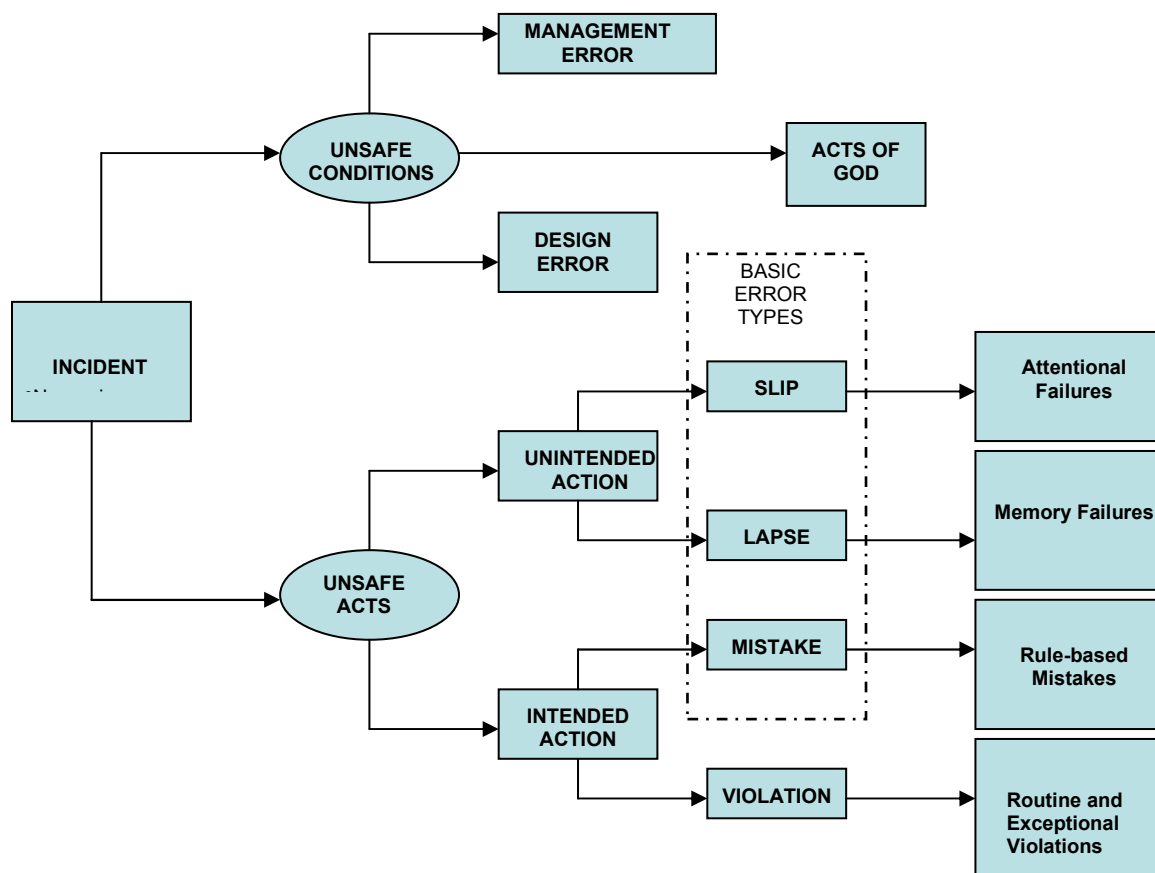

Figure 1.4 – The two-factor model

1.4.2. Chain of Events Theory

A study performed by the Naval Surface Weapons Center in Silver Spring, Maryland, was first to apply the chain of events theory (Fine 1975). The Navy concluded that seemingly clear-cut cases were actually the result of poor upstream management. In fact, the Navy concluded that virtually every incident could have been prevented through proper safety and health management. In other words, incidents occurred because management failed to act during events in a series that ultimately resulted in an accident. Furthermore, if any event in the chain had not occurred, the accident might have been averted. In many cases, the last error in a series of poor decisions is performed by the injured worker. Thus, it is common for many injuries to be blamed on worker behavior.

Building upon the chain of events theory, James Reason created what is known as the “Accident Trajectory Model” or “Swiss Cheese Model.” Reason takes the chain of events theory a step further showing that each event in the chain creates a hole in a specific line of defense. If any one line of defense were perfect, incidents would not occur. This model is described in more detail in the following paragraphs.

1.4.3. Reason’s Accident Trajectory Model

According to James Reason, accidents can be prevented through the effective implementation of three filters: facility design, shaping factors and work conditions. However, errors and omissions in any of the three filters will result in an incident (i.e. injury or near-miss). The holes in the model in Figure 1.5 represent such errors or omissions. Effective safety programs minimize the presence of errors or omissions in one or more of the three filters. Since the meaning of each filter is not clear from the model, a definition for each of these filters is provided.

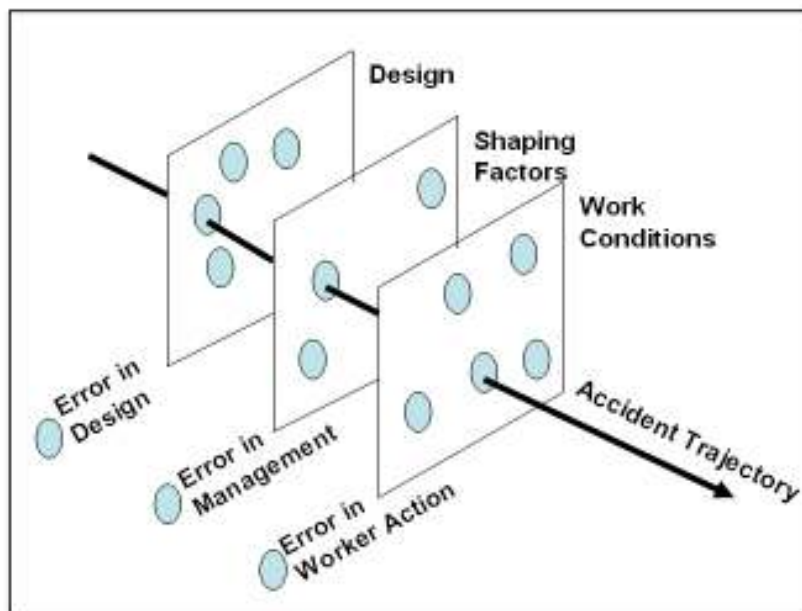

Figure 1.5 – Reason’s Accident Trajectory Model

1.4.3.1. Design

According to numerous publications, explicit consideration of construction safety and health issues by the designers of facilities (i.e., architects and engineers) may serve as a preventative filter for construction safety accidents (Gambatese, Hinze et al. 1997; Gambatese 2000; Gambatese, Behm et al. 2005; Toole 2005; Toole, Hervol et al. 2006). If properly implemented, safety hazards can be designed-out during the design phase of a project. That is, the explicit consideration of safety during design may significantly reduce the number of potential hazards on construction sites. According to Reason's theory, if the design for safety process were to be perfect, no hazards would exist during construction. In construction, however, the design for safety technique is still in its infancy and remains relatively unsophisticated. Construction safety management techniques, on the other hand, are far more established.

1.4.3.2. Shaping Factors

In the accident trajectory model, model shaping factors include all of the activities conducted by the general contractor's safety management team. Typically, this team consists of several classifications of management including foremen, superintendents, crew leaders, and safety managers. The quality of the work shaping filter depends on the ability of the contractor's employees to recognize and remove hazards. Errors and omissions in this filter occur any time a safety risk goes unnoticed. For example, if management does not recognize that work will take place directly below a mason working at height, the risk of a falling masonry block resulting in an injury is still present. This risk is manifested in Reason's model by a hole in the filter.

1.4.3.3. Work Condition

The final line of defense in this model is the worker interaction with the work site. Workers who are trained to recognize and avoid uncontrolled hazardous exposures are able to prevent harm not only to themselves, but to their fellow workers as well. Several

safety program elements are geared toward safety training. An error in this filter may occur when a worker does not recognize a hazardous exposure, when a worker has a slip or lapse in judgment, or when the worker acts unsafely on purpose.

1.4.3.4. Accident Trajectory

According to Reason, an accident will only occur when there is an error in all three filters and when these errors are in perfect alignment. That is, the designer, management team, and the worker must all fail in order for an accident to occur. Even with best efforts, it is not possible to be perfect. Therefore, holes will always exist in the filters and accidents are always a possibility (i.e., safety risk cannot be reduced to 0). However, it is possible, through effective safety management to prevent the vast majority of accidents.

The following model, created by Marcum and Veltri, also illustrates that incidents are the result of a chain of events and that the use of proper filters (e.g., management techniques and training) can reduce incidents. This model elaborates on Reason's trajectory model by illustrating the proper management techniques that can be used as countermeasures. In other words, methods for filling the gaps in Reason's model are provided.

1.4.4. Marcum and Veltri's Analytic Model

As part of a paper describing the failures of organizations to effectively protect and use their resources effectively, Veltri and Marcum created a risk, danger, and loss model that describes not only the causal factors that lead to a contact incident but also the loss problem and advancement problem domains that follow (Figure 1.6).

This model indicates that five interrelated problem domains exist in sequence. These problem domains are as follows: integration, risk, danger, loss, and advancement. These domains are in turn classified in three sub groups: causal, danger, and effect factors. Causal factors include the integration and risk problem domains while the effect factors

naturally include the loss and advancement problem domains. Perhaps the most notable aspects of the model are its tracking and countermeasure features. According to Veltri (2006), the risk, danger, and loss model as well as the countermeasure strategies draw heavily from works by Heinrich (1931), Bird (1975), and Marcum (1978).

The objectives of this model are two-fold. Analysts may use the model to both track forward and backward from the moment of an incident and reveal the countermeasures to prevent each organizational short-coming. Tracking backward allows the analyst to determine the cause of an incident while forward tracking allows the analyst to reveal the direct effects of the incident. When one tracks backward from a contact incident root causes are revealed such as: “ineffective managerial actions, non-integrated risk/loss control efforts, and obsolete management approaches.” In other words, Marcum and Veltri suggest that preventative responsibility must be charged back to management that allowed the integration and risk problem domains to exist. While all the features and specifics of this model are too numerous to describe in this manuscript, it is clear that this model affords an analyst with the luxury of identifying the cause and effect factors of an incident and the measures that may be taken to learn from the incident and prepare the organization from future risk. Building even further, Mitropolis, et al. (2005), present a systems model of accident causation. Like Marcum and Veltri’s model, the systems model shows that incidents are the result of many factors and incidents can have a variety of impacts. Because the systems model describes the various interrelationships between all factors, it is considered by the author to be the most advanced of all current accident causation models.

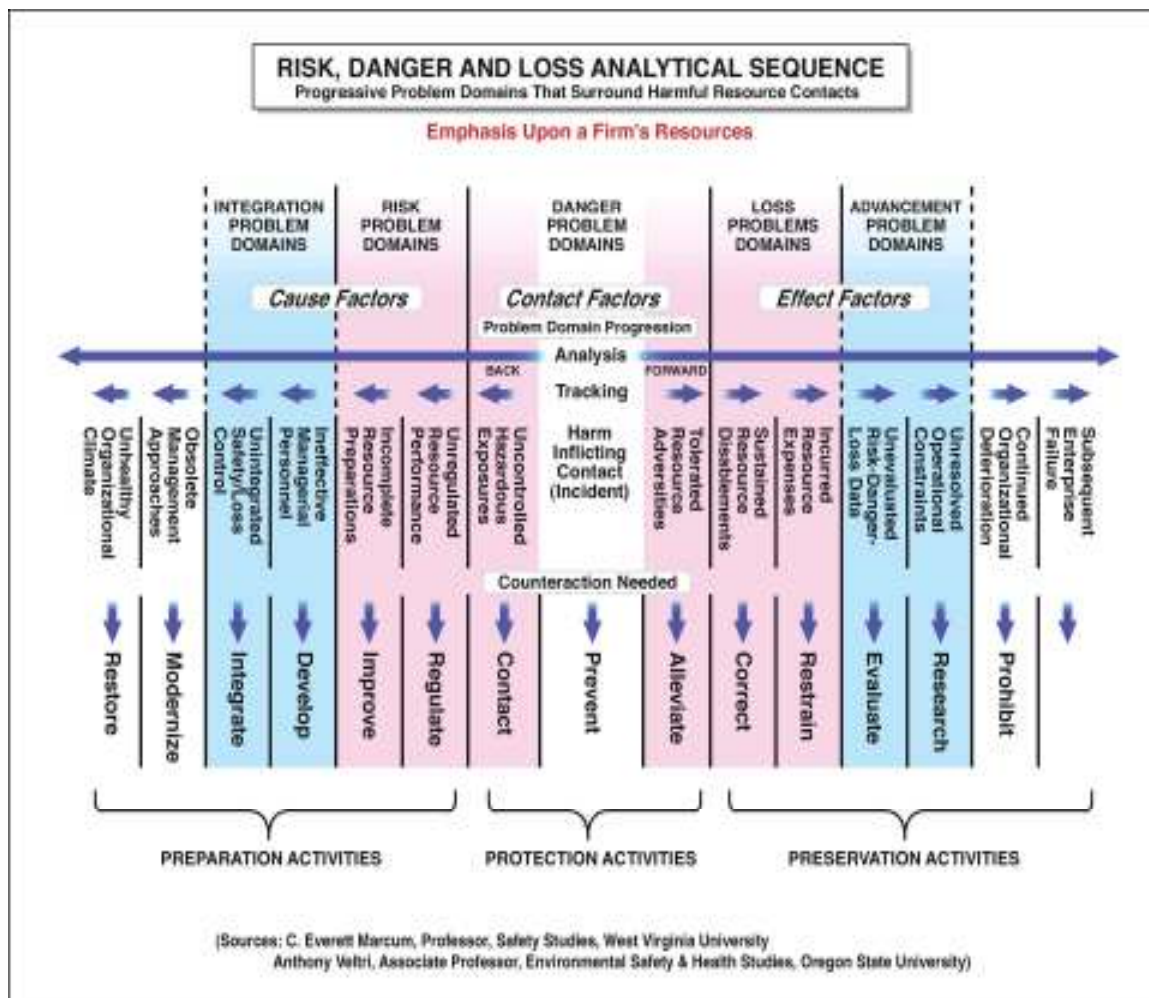

Figure 1.6 – Marcum and Veltri’s Analytic Model

1.4.5. Systems Model of Accident Causation

Mitropolis et al. (2005) describe the conditions surrounding an incident as a system. Their paper develops a causation model that focuses on the activity-level as opposed to event-based modeling, takes a systems view in lieu of a linear view of accident trajectories, and is based upon a descriptive, rather than prescriptive model of work behavior.

Mitropolis et al. acknowledge the work of Rasmussen (1997) and the chain of events theory when creating their system. The system developed by Mitropolis et al. is illustrated

in Figure 1.7. Since the model is very involved, it is outside the scope of this manuscript to include an in-depth discussion of the model's components. Therefore, the author refers the readers to Mitropolis et al.'s 2005 publication cited above. To aid the reader in their understanding of the systems model, a brief description of a system and the modeling technique is provided below.

Systems models contain a variety of features. Most notably a model has a boundary that defines the elements that are included in the model and those that are not. Similarly, a model has well defined inputs and outputs. Once these elements have been defined, the interrelationships, or throughput, may be defined. Figure 1.7 illustrates only the throughput defined by Mitropolis et al. (2005). In this system, the signs indicate the direction of the relationship between the factors; a positive sign indicates that when the causal factor X changes, the effect Y changes in the same direction (i.e., as X increases Y increases, or as X decreases Y decreases). A negative sign indicates that the effect changes in the opposite direction (i.e., as X increases Y decreases, or as X decreases Y increases).

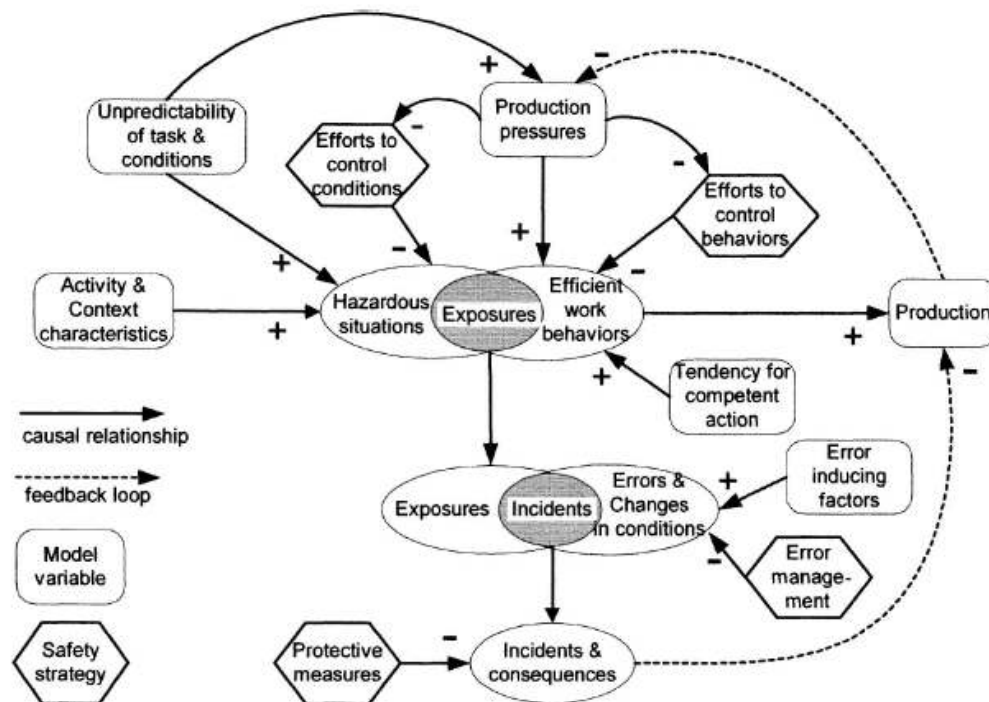

Figure 1.7 – Accident causation model

Each of the models presented in this manuscript are unique but subsequently build upon the concepts researched and assembled by previous studies. Only one of the models, Marcum and Veltri's analytic model, provides specific guidance for safety and health management. Furthermore, no model provides direct guidance for the selection and implementation of safety program elements. Therefore, the study presented in this dissertation proposes a new model that illustrates both the safety and health conditions and the management methods that can be used to reduce the risk of an incident that compromises construction safety.

1.5. CURRENT SAFETY AND HEALTH MANAGEMENT STRATEGIES

1.5.1. Introduction

Since the proposed model aims to guide a constructor in their selection of safety program elements, the current methods implemented by contractors must be identified. First, literature is reviewed to determine if the current methodology has been published. As one will see, this documentation is limited. Therefore, exploratory research is performed to identify current methods.

1.5.2. Literature

The vast majority of construction safety literature focuses on identifying and describing the various methods of improving site safety (i.e. safety program elements). Strategies such as job hazard analyses, record keeping, and substance abuse programs are well-defined. Literature also provides excellent justification and guidance for implementation of some fifty safety program elements. Some publications, such as Hinze (1997) and Hill (2004), go as far as to identify the essential elements of effective safety programs. Another publication, Rajendran (2006), evaluates the relative ability of safety program elements to improve site safety. This research assigns a point value to approximately fifty elements in a safety rating system modeled after LEED™. None of the publications reviewed identify specific methods for selecting a subset of safety program elements.

Each of the publications discussed above operates under the same fundamental assumption: a firm should implement as many safety program elements as their budget permits. This literature also implies that safety program elements should be applied to a construction site or firm in general and does not identify their relative ability to mitigate safety risks for specific processes. Most troubling, however, is the fact that there is no guidance for constructors with limited resources that can only implement a small subset of the fifty elements. This is true despite the fact that small firms represent the vast majority of the industry.

The very small body of safety risk literature focuses primarily on risk quantification methods. For example, Baradan and Usmen (2006) discuss the comparative injury and fatality risks in the construction of buildings using data provided by the Bureau of Labor Statistics (BLS). Likewise, Lee and Halpin (2003) created a predictive tool for estimating accident risk in construction using fuzzy inputs from the user. Unlike the research of Baradan and Usmen, this paper introduces a method of assessing accident potential rather than retrospective data provided by the BLS. Both of these studies evaluate techniques for identifying and quantifying safety risks in construction. However, neither study provides guidance for mitigating safety risk.

One study combines construction safety risk identification with mitigation techniques. Jannadi and Almishari (2003) introduce The Risk Assessor, a knowledge-management program, which quantifies risk using the common risk formula below:

$$\text{Activity Risk Score} = (\text{Severity}) \times (\text{Exposure}) \times (\text{Probability})$$

Using similar methods as Lee and Halpin (2003) and Baradan and Usmen (2006), this software may be used by construction professionals to identify activities of particularly high risk. Unfortunately, the software does not identify specific methods for mitigating the safety risk. Instead, the program relies heavily on the expertise of the user and assumes that viable methods of risk mitigation have been previously identified. Once a corrective measure has been selected and input into the program, The Risk Assessor serves as a platform that may be used to financially justify any corrective measure.

This manuscript aims to build upon existing literature by introducing a formal method for strategically matching safety program elements to construction processes. This decision scheme assumes that every construction activity is associated with specific safety risks and that each safety program element is capable of mitigating a portion of such risks. Before introducing this model, the current methodology for selecting safety program

elements will be explored. In order to understand the implications of the proposed model, one must fully understand the current safety management practices that dominate the industry.

1.5.3. Research Method

The dominant research method used for this dissertation is the Delphi method. This research method, its application to the research, methods for reducing bias, etc. is described in great detail in the following manuscript. During the creation of the Delphi panel, 29 construction safety experts were asked to identify the prevailing methods implemented by general contractors for selecting safety program elements. Potential experts were identified and selected from the ASCE Site Safety Committee, the ASSE Construction Safety Specialty Committee, and from contacts provided in peer-reviewed publications. See sections 2.5 for a complete description of the demographics of the experts and their qualifications. For reference, a brief description of the panelist's qualifications is provided below.

In order to be qualified as an expert, the panelists were required to meet at least four of the eight requirements listed in Table 1.3. Criteria for expert qualification was obtained from guidelines from Delphi studies such as Veltri (2006), Rogers and Lopez (2002) and Rajendran (2007). In addition to these requirements, Table 1.3 also indicates the percentage of qualified expert panelists who met each requirement in this study. After assigning one point for meeting or exceeding each of the 8 criteria, the median score was a 6. In other words, the median expert met 6 of the 8 requirements. Only the responses from the qualified experts were used in this study.

Input from experts is desirable for this study because individuals that meet the requirements in Table 1.3 are likely to have a holistic understanding of the construction industry. A holistic understanding of the construction industry was necessary because one objective of the research was to collect data that would represent the behavior and

experience of the entire industry. Collecting subjective data from certified experts was also the chosen methodology due to the lack of objective data and the difficulty in collecting data from all types of projects.

Table 1.3 – Expert Qualification (n = 29)

Requirement	Percentage of experts meeting the qualification
1. Primary or secondary author of a peer-reviewed journal article on the topic of construction safety or health	62%
2. Invited to present at a conference with a focus on construction safety or health	86%
3. Member or chair of a construction safety and health-related committee	93%
4. At least 5 years of professional experience in the construction industry	97%
5. Faculty member at an accredited institution of higher learning	41%
6. Author or editor of a book or book chapter	45%
7. Advanced degree from an institution of higher learning (minimum of a BS)	97%
8. Designation as a Professional Engineer (PE), Certified Safety Professional (CSP), Associated Risk Manager (ARM) or a Licensed Architect (AIA)	79%

1.5.4. Findings

Experts were asked to use their experience to select the strategy that most contractors employ when choosing safety program elements for a particular construction project. The survey sent to the expert panels can be found in Appendix A. As one can clearly see from Table 1.4, there is very little consensus, even among the experts, regarding the method of selecting safety program elements. The highest degree of consensus was that small and medium-sized contractors select elements by word of mouth and that elements are chosen based on intuition and judgment for all contractor sizes. One should note that the experts were not told what defined small, medium and large contractors. In addition to the percentages indicated in Table 1.4, several additional methods employed by contractors

of all sizes were mentioned, such as guidance and/or requirements from insurance companies (11% of the experts), guidance from OSHA (33%), and Owner requirements (22%).

The findings from this survey confirm the hypothesis that elements are chosen in an informal fashion and that there is no unified method currently implemented in the industry. In fact, no experts mentioned a formal method for selecting safety program elements based upon their relative ability to mitigate risks on construction sites. These findings support the premise that a formal method for selecting elements based on their relative ability to mitigate risk could be useful in the construction industry.

Table 1.4 – Methods of selecting safety program elements (percentage of experts)

Method	Contractor Size		
	Small	Medium	Large
Safety program elements are chosen at random	50 %	4.5%	0%
Elements are chosen based on intuition and judgment	59 %	63.6 %	59 %
Elements are chosen based on word of mouth	63.6 %	63.6 %	22.7 %
Elements are chosen based on literature	13.6 %	50 %	77.2 %
Contractors implement as many safety program elements as the budget permits	31.8 %	50 %	45.5 %

Experts were also asked if their firm implemented a formal method of evaluating safety risk and the effectiveness of their safety program elements. None of the experts reported such a formal method.

1.5.5. Conclusions and Recommendations

The lack of guidance in literature for the selection of safety program elements and evaluation of construction safety risk is evident from Table 1.4. Contractors clearly do not have a cohesive or advanced strategy. Therefore, the author proposes a new model that evaluates safety and health risk of construction processes and can be used as a formal method for the strategic selection of safety program elements.

The remaining sections of this manuscript introduce and describe a formal method of construction safety management. The creation of the model involves merging concepts from structural engineering and risk management and applying them to the field of safety management. First, the basic theoretical concept of equilibrium from the field of structural engineering is applied to safety and health. Based upon the concept of equilibrium, a model that incorporates risk management techniques is formulated. Finally, the implementation and implications of the model is discussed.

1.6. SAFETY EQUILIBRIUM MODEL

This section of the manuscript provides the reader with the theoretical framework for a risk-based model for construction safety and health management. The model can be used to evaluate safety and health risk given specific activities and safety efforts. The theoretical model introduced in this section is populated in manuscripts two and three and is illustrated and validated in manuscript four. The model is clearly needed for the following reasons:

- Analysis of safety and health statistics indicates that construction accounts for a disproportionate injury and illness rate (Section 1.3.1)
- The costs associated with construction safety incidents are very high (Section 1.3.2)

- Many inherent characteristics of the construction industry such as dynamic work environments and culture make construction safety management very complex (section 1.3.3)
- Existing models do not involve risk-based analyses or guidance for the selection of safety program elements (sections 1.4)
- Currently, the construction industry does not have a cohesive or formal method for the selection of safety program elements or evaluation of the risk mitigation ability of these elements (Section 1.5.4)

The theoretical model presented here is based upon a physics concept that may seem out of place to the reader. The author contends that the concept of equilibrium can be applied to safety and health management. In theory construction sites can be risk-free if the ability of the safety program elements to mitigate risk exceeds or equals the total risk associated with a process. This theory drives the proposed model and is based on the concept of equilibrium (Newton's third law). The concept of equilibrium is discussed first and the application of the concept is discussed in subsequent sections.

1.6.1. Equilibrium

The concept of equilibrium, based upon Newton's third law, is widely known in the fields of physics and engineering. Simply put, Newton's third law states that for every action there must be an equal and opposite reaction. In structural engineering, this concept is employed when designing systems to support various loading schemes. In order to be structurally effective, a system must be designed in such a way that the capacity of the system is greater than or equal to the maximum anticipated load. In other words, the system's capacity must meet or exceed the loading demand. This relationship is illustrated in the following design relationship for flexure in a structural member:

$$M_u \leq \Phi M_n \quad \text{where,} \quad (\text{Eq. 1.1})$$

M_u : Ultimate Moment (i.e., maximum design demand),

M_n : Design Moment (i.e., nominal moment or capacity),

Φ : Factor of Safety

When this same concept is applied to construction safety, one may recognize that the safety risk demand is equal to the sum of the safety risk on a construction site. Assuming that every safety program element offers some form of safety risk mitigation, the sum of that mitigation ability is equal to the capacity of the safety system. In theory, to reach equilibrium and make the safety system stable (i.e. accident-free), the capacity of the safety program must meet or exceed the safety demand. This relationship is expressed in the following expression (Equation 2), modeled after Equation 1.

$$S_u \geq \Phi S_n \quad \text{where,} \quad (\text{Eq. 1.2})$$

S_u : Safety Risk Demand (i.e. the cumulative safety risk on the construction site)

S_n : Safety Capacity (i.e. the cumulative mitigation ability of the safety program)

Φ : Factor of Safety

One will note that a factor of safety is included in both equations. As with any engineered system, a factor of safety should be employed to compensate for potential errors and uncertainty in the quantification of demand values (e.g. loading or cumulative safety risk) or capacity (e.g. strength of the system or ability of the safety program to mitigate risk).

1.6.2. Quantifying Demand and Capacity

In order to apply the concepts presented in the safety equilibrium equation, one must identify and define both the safety risk demand and the capacity of the safety program. Several publications provide guidance for the identification and quantification of safety risk such as Jannandi and Almishari (2003), Lee and Halpin (2003), and Baradan and

Usmen (2006). Defining the capacity of the safety program is a bit more abstract. One method for quantifying both capacity and demand is outlined below.

Before continuing with the manuscript, it is necessary to define the concept of safety risk. Here, risk is defined as a potential event that results in an outcome that is different from planned. For construction safety, risks are defined as potential incidents. There are two main components of risk: probability and severity. Probability defines the chance or rate of occurrence of an incident. For safety risk, probability may be defined in terms of worker-hours per incident. Severity, on the other hand, defines the magnitude of the outcome. Severity may be defined in monetary terms or in terms of the degree of injury (e.g. fatality, lost work-time, medical-case, etc.). The product of these two components is the risk value. This relationship is expressed in the following equation, modeled after Yi and Langford (2006):

$$\text{Risk (R}_i\text{)} = \text{Probability (p)} \times \text{Severity (s)} \quad (\text{Eq. 1.3})$$

In terms of safety, the probability of an accident is typically expressed in the form of an incident rate such as the number of worker-hours per incident. Severity, on the other hand, is more difficult to quantify. The author offers well-defined and justified probability and severity scales in Manuscript 2.

1.6.3. Demand

Quantifying the risk demand for a construction process is not a simple task. However, literature provides significant guidance. The method of quantifying the safety risk demand involves both the identification and analysis of the safety risk. Figure 1.8 defines one method of identification and analysis. While this figure is purely theoretical and does not attempt to define actual quantities of activities or risks, it provides the reader with a structured method that may be applied to any construction process. This method is illustrated in Manuscript 2 using concrete formwork as an example. Figure 1.8 is

intended to convey 5 steps required to quantify the collective safety demand for a specific construction process. These steps are as follows:

1. Identify common safety risks

First, one must define common construction safety risks, denoted R_1 through R_n in Figure 1.8. The author suggests the Bureau of Labor Statistics and Occupational Safety and Health Administration's Occupational Injury and Illness Classification System (OIICS) as a starting point (BLS 2007). This classification system lists and defines common safety risks.

2. Identify activities required for a construction process

The second step involves defining the typical activities associated with a particular process. For example, constructing formwork may include activities such as cutting raw material, transporting material, erecting panels, etc. In Figure 1.8, activities are denoted A through Z. One should note that an individual close to the work, such as a foreman, is typically best qualified for identifying the activities required for any given process.

3. Identify and quantify the risks associated with each activity

For each activity identified in step 2 the common safety risks that may occur when performing each activity must be identified and quantified. For the theoretical example provided in Figure 1.8, activity A is associated with risks 1, 2 and 5. In order to calculate risk using Equation 3, the user must then assign a probability and severity value for each risk associated with each activity once the connections have been made.

4. Sum the quantified risks for each activity

The risk values for each activity (e.g. ΣA) may be calculated by summing the risk values associated with the activity. In Figure 1.8, the total risk value for activity A would be calculated by summing the risk values for risks 1, 2 and 5.

5. Calculate the total risk demand by summing the risk values for all activities

The total risk demand, S_u , for a particular process may be calculated by summing the total risk values of all of the activities. S_u may be calculated using equation 1.4.

$$\sum_{Act.=A}^Z [\sum_{R1}^{Rn} (\text{Safety Risk})] = S_u = Demand \quad (\text{Equation 1.4})$$

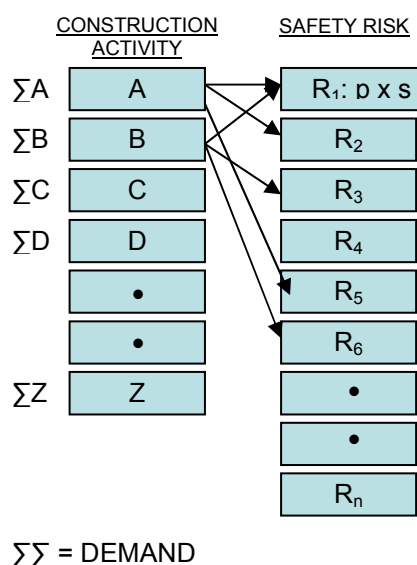

Figure 1.8 – Safety Risk Demand

1.6.4. Capacity

The capacity of a safety program can be quantified in a similar method as the risk demand. Rather than calculate the risk value, one must calculate the risk mitigation when

defining capacity. In a structural system, this process involves calculating the maximum load a structure may support. Similarly, in a safety system this process involves quantifying the total risk mitigation ability of the safety program. As with risk demand quantification, there are two components to consider: reduction in probability and reduction in severity. One must be careful to use the same units of probability and severity when defining both demand and capacity.

Unlike safety risk demand, there has yet to be an attempt to quantify the mitigation ability of a safety program. However, quantifying this value is necessary to use the equilibrium equation. Figure 1.9 may be used as guidance when calculating the risk capacity of the safety program. The specific process required for the quantification of capacity can be summarized in the following 5 steps:

1. Identify common safety risks (e.g. OIICS)

Use the same risks identified when calculating demand.

2. Identify viable safety program elements

A safety or risk manager should identify the safety program elements that their firm is currently capable of implementing or those that the firm is considering for implementation. Significant guidance is provided in literature, such as Hill (2006) and Hinze (1997).

3. Identify and quantify the ability of safety program elements to mitigate a portion of the common safety risks

In theory every safety program element is capable of mitigating a portion of the probability or severity of safety risks. For example, job hazard analyses may be extremely effective in reducing the probability of a particular safety risk and somewhat

effective in reducing the severity of the risk. The mitigation ability of each safety element should be defined for each risk. The risk mitigation may be calculated using a modification of Equation 1.4 where the risk mitigation is equal to the product of the probability reduction and severity reduction. The resulting equation becomes Equation 1.5.

4. Sum the mitigation ability for each safety program element

The risk mitigation values for each safety program element (e.g. $\sum \alpha$) may be calculated by summing the risk reduction values associated with the element. In Figure 1.9 the total risk mitigation value for element α would be calculated by summing the risk mitigation values for risks 3 and 6.

5. Calculate the total capacity of the safety system by summing the mitigation ability of the safety program elements planned for implementation

The total risk capacity, S_n , for a particular safety program may be calculated by summing the total risk mitigation values of all safety program elements implemented on a project. This may be a subset of the collection of safety program elements that the firm has available.

$$\sum_{El.\alpha}^{\zeta} \left[\sum_{R_1}^{R_n} (\text{Safety Risk Mitigation}) \right] = S_n = \text{Capacity} \quad (\text{Equation 1.5})$$

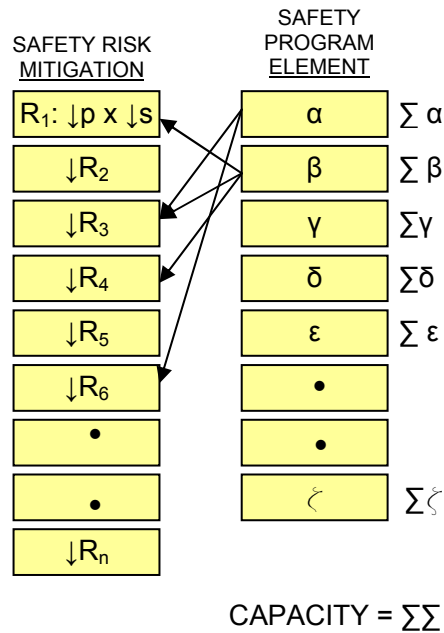

Figure 1.9 – Safety Risk Mitigation

1.6.5. Application of the equilibrium concept

Once the safety risk demand has been quantified, the equilibrium equation (Equation 1.2) may be applied. By using the concept of equilibrium and the quantified risk mitigation capacity of each safety program element, one may define the relative effectiveness of safety program elements and identify when equilibrium between safety risk demand and the capacity of the safety program has been achieved. The concept of equilibrium is illustrated in Figure 1.10.

The practical application of this model requires the knowledge of an expert or experts in the field of construction safety. The individual or group that identifies and quantifies the risks that comprise the safety demand and capacity must have extraordinary knowledge of the work process, safety risk implications of the activities, and the effectiveness of individual safety program elements. For this reason it is suggested that multiple individuals should be involved when implementing the model. For example, a foreman

may be the most knowledgeable employee for defining the activities required for a process, the safety manager may be the most effective person for identifying the risks associated with the construction activities, and a risk manager may be the most effective person for quantifying the risk demand and mitigation values. Collectively, such a safety risk task force may be extremely effective.

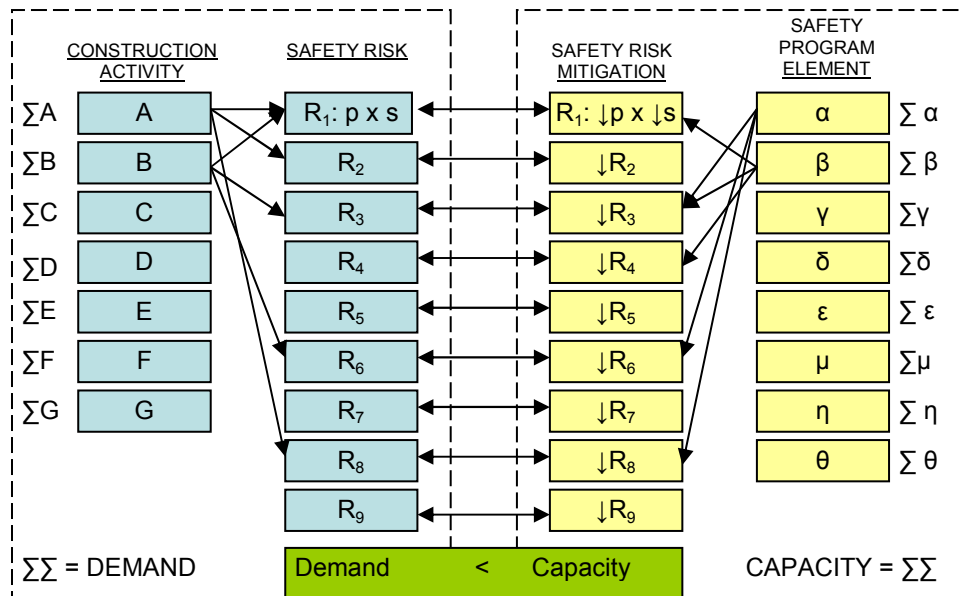

Figure 1.10 – Safety Equilibrium Model

1.7. CONCLUSION

This manuscript has reviewed the importance of construction safety research, several safety and health analytic models, and current safety and health management practices in construction, and presents a formal risk-based model for construction safety management. As indicated previously, the focus of this dissertation is the introduction, population, and validation of this risk-based model. The following manuscript focuses on the concept of safety risk demand. The concept of demand is revisited and the current methods of risk quantification are reviewed. Most importantly, however, the activities required to construct concrete formwork are identified and the risk values for each of these activities are quantified using the Delphi procedure. In other words, the specific risk demand for

the activities associated with the process of constructing concrete formwork is quantified. Following manuscript three, the fourth manuscript focuses on the quantification of the ability of specific safety program elements to reduce a portion of construction safety risks. Finally, these two concepts are combined in a fully-populated equilibrium model that is validated using current data obtained from the industry.

MANUSCRIPT 2.0
SAFETY RISK DEMAND FOR THE CONSTRUCTION OF
CONCRETE FORMWORK

Matthew R. Hallowell

2.1. PREFACE

The first manuscript of this dissertation provided the reader with compelling evidence that construction safety research is extraordinarily important. Additionally, several safety and health analytic models were highlighted, current safety and health management practices in construction were reviewed, and a formal risk-based model for construction safety management was introduced. Manuscript 1 serves as the foundation for the remainder of this dissertation.

In the present manuscript, the author attempts to populate the safety risk demand portion of the theoretical model outlined in Manuscript 1 using the process of constructing concrete formwork as an example. In other words, the primary objective of this manuscript is to describe a study that quantified the probability and severity of safety risks associated with the activities required to construct concrete formwork.

To structure the model, the author identifies the potential construction safety risks using an augmented version of the Occupational Safety and Health Administration's Occupational Illness and Injury Classification System (OIICS) and conducts field observations and industry surveys to determine the worker activities required to construct concrete formwork. To populate the model (i.e., define the probability and severity of each construction safety risk for each activity), the Delphi process is implemented.

2.2. INTRODUCTION

As indicated previously, the purpose of this manuscript is to identify and quantify safety risks associated with a construction process. Two forms of data were collected to achieve this objective. First, the activities associated with the construction of concrete formwork are identified, classified, and described. Second, data is collected to quantify the probability and severity of the construction safety risks associated with each activity.

Before proceeding, it is appropriate to revisit the concept of demand introduced in Manuscript 1 as its quantification is the central theme of this manuscript. According to Hallowell and Gambatese (2007), the method of quantifying the safety risk demand requires one to identify and analyze all safety risks in a formal and methodical fashion. When quantifying the safety demand associated with a process, one must perform the following five activities:

1. *Identify common safety risks*
2. *Identify activities required for a construction process*
3. *Identify and quantify the risks associated with each activity*
4. *Sum the quantified risks for each activity*
5. *Calculate the total risk demand by summing the risk values for all activities required for the process*

The activities described in the above five steps are illustrated in Figure 2.1. This figure has been reproduced from Manuscript 1.

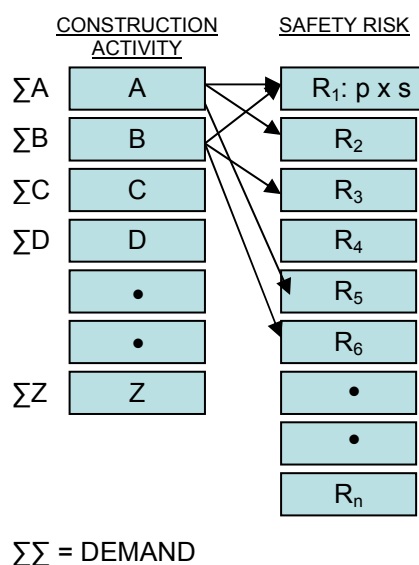

Figure 2.1 - Safety risk demand

To illustrate the concept of safety risk demand, the author has chosen the process of constructing concrete formwork. Formwork construction was selected because archival literature, Bureau of Labor Statistics data (BLS 2007), and Occupational Safety and Health Administration Fatality Reports (OSHA 2007) indicate that formwork construction is associated with a relatively high frequency of disabling injuries and illness. Similarly, ergonomic studies suggest that the repetitive activities of lifting, sawing, and hammering commonly performed by formwork carpenters lead to a high probability of low severity injuries such as discomfort and persistent pain (Har 2002). Furthermore, the process of constructing formwork was selected because formwork is involved in some capacity on nearly every non-residential building construction project. Finally, preliminary observations and the experiences of the author indicate that the work activities required to construct formwork are easily identifiable, encompass the work activities required of many other construction processes, and involve a manageable number of worker activities (between 10 and 30). Several articles that illustrate the high

risk of formwork construction relative to other common building trades are summarized below.

In an analysis of the number of falls by occupation and process recorded by the Korean Occupational Health and Safety Administration (KOSHA), most fatalities due to falls occurred in the process of constructing concrete formwork (Yi and Langford 2006). In fact, an analysis of 1997 OSHA accident reports revealed that 5.83 percent of falls were attributed to the construction of formwork or the construction of temporary structures (Huang and Hinze 2003). Additionally, 21.2 percent of all struck by accidents involved wood framing or formwork construction (61 of 288 cases).

According to Sommers (1982), 54 percent of all construction failures between 1964 and 1974 were due to failure of concrete formwork. Furthermore, formwork carpenters are typically subjected to productivity pressure as formwork construction activities are commonly on the critical path. Formwork accidents were found to be most common in the latter half of the workday when productivity pressures are the greatest. Sommers (1982) also claims that formwork failures can be prevented through proper planning and advanced safety programs.

In addition to the high severity, low probability risks, formwork construction also involves a significant portion of low severity, high probability risks. In a recent publication, Har (2002) found that formwork carpenters are at high risk for musculoskeletal injuries caused by poor ergonomics and repetitive work activities. The combination of a high proportion of fatalities and disabling injuries and the high volume of low severity, high probability risks may make formwork one of the highest risk processes in construction. Moreover, when one considers that formwork construction is involved on nearly every non-residential building construction project (i.e., the construction industry is highly exposed to this high risk process), it becomes obvious that the construction industry is in dire need of rigorous academic research on the topic of

quantification, modeling, and mitigation of formwork risks. Therefore, this dissertation will focus on the safety risk demand associated with the construction of concrete formwork.

The following section of the manuscript presents literature that describes risk quantification methods, safety risk classification systems, common worker activities required to construct concrete formwork, and specific risks that are especially high for formwork construction.

2.3. LITERATURE REVIEW

The following literature review is divided into four main sections: the review of methods for evaluating and quantifying construction risks, construction safety risk classification systems, activities required to construct concrete formwork, and an analysis of OSHA formwork construction safety risk reports. One should note that further literature review is also included in the methodology section of this manuscript (section 2.4). Literature in the methodology section applied specifically to the research methods implemented in this study.

2.3.1. Methods Implemented to Quantify Risk in Construction

Most safety risk literature focuses on risk analysis and the relative risk levels among trades or industries. For example, Baradan and Usmen (2006) discuss the comparative injury and fatality risks for trades involved in the construction of buildings using data published by the Bureau of Labor Statistics (2007). Likewise, Lee and Halpin (2003) created a predictive tool for estimating accident risk in construction using fuzzy inputs from the user.

One of the most common methods of quantifying safety risk, employed by Jannadi and Almishari (2003) and Baradan and Usmen (2006), is illustrated in Equation 2.1. According to this equation, risk is composed of three primary components: probability,

severity, and exposure. In risk quantification, probability refers to the chance of a potential event (e.g., number of events per day), severity represents the potential outcome of an event (e.g., dollars per event), and exposure describes the duration of potential contact with a potentially hazardous situation (e.g., days). The role of exposure is to convert a unit risk (e.g., dollars per day) to a cumulative risk (e.g., dollars). Both of the studies cited above evaluate techniques for identifying and quantifying safety risks in construction. However, neither study indicates how the spectrum of probability and severity levels should be defined or communicated to the workforce.

$$\text{Activity Risk Score} = (\text{Probability}) \times (\text{Severity}) \times (\text{Exposure}) \quad (\text{Eq. 2.1})$$

2.3.1.1. *Probability Quantification*

Quantifying the probability of event occurrence is a seemingly easy task. When analyzing safety risk, the most commonly-used units of incident frequency are: recordable incident rates and subjective measures. Brauer (1994) classifies probability as frequent, probable, occasional, remote, and improbable. Baradan and Usmen (2006) take a more advanced approach by calculating incident rates using data published by the Bureau of Labor Statistics (BLS). For non-fatal injuries, BLS data is reported in terms of incident rate (i.e., number of injuries or illnesses per 100 full-time workers) while the probability of fatality is reported as the number of deaths per 100,000 full-time workers. While this approach to calculating probability of construction safety incidents is more advanced, one should note that the BLS data is only recorded and published for very high severity incidents (i.e., lost work-time incidents and fatalities). A risk analysis that incorporates only high-severity, low-probability data ignores a significant portion of risk, namely high-probability, low-severity events. According to basic risk management theory, comprehensive and formal risk analysis should include all types of risk.

2.3.1.2. *Severity Quantification*

While probability lends itself well to quantification through the use of incident rates, quantifying severity is more abstract. It is not surprising that most safety studies concentrate on two severity levels: lost work-time incidents and fatalities. As previously indicated, data is rarely collected for low-severity injuries such as minor musculoskeletal injuries or persistent pain despite the fact that many studies indicate that these injury types are also high risk (Hess et al. 2004). In other words, the product of probability and severity for low-severity injuries may be comparable to that for high severity injuries. Therefore, it is important to define a continuous measure of severity that includes both low-severity injuries and high fatality injuries.

Several publications such as Hinze (1997) and Hill (2004) describe the range in severity of several incident types. Likewise, the Canadian Organization of Oil Drilling Contractors (2004), and the Occupational Safety and Health Administration (2007) have produced online resources that define a spectrum of possible incident severities. Using these publications as guidance, definitions of a few incident severity types are included below.

Fatality: A work related injury or illness that results in death.

Lost work-time: An injury or illness that prevents an employee from returning to work the following workday.

Restricted work case: An injury or illness that prevents an employee from performing work in normal capacity, but does not result in days lost from work.

Medical Treatment Only: Any work related injury or illness requiring medical care or treatment beyond first aid. In this category the worker must be able to return to their regular work and function in normal capacity.

First Aid: Any treatment of minor scratches, cuts, burns, splinters and so forth. In this category the worker should be able to return to work following the first aid treatment.

With the exception of first-aid injuries, the above incident types would be considered “OSHA recordable.” That is, US Federal Law requires that employers record these injuries in the employer’s occupational injury log. However, as many construction professionals and researchers are well aware, there are a significant number of incidents that result in minor injuries such as persistent pain, temporary pain, discomfort, and close-calls. In fact, Heinrich (1931, as cited in Hinze 1997) claims that for every major injury there are 29 minor injuries and 300 no-injury incidents. It is the opinion of the author that ignoring the contribution of these high-probability, low-severity events is a major flaw in most construction safety literature and risk analyses.

Studies that focus on construction ergonomics have reported that a significant portion of construction related claims involve low-severity incidents. For example, Hess et al. (2004) found that strains and sprains accounted for 31.5 percent of workers’ compensation claims by union construction laborers in the state of Washington between 1990 and 1994. While most of these incidents are not “OSHA recordable” and would not be reflected in BLS annual statistics, they represent a large portion of the yearly workers’ compensation costs. Because high-severity injuries such as fatalities and disabling injuries involve a relatively high number of workers’ compensation claims, this data suggests that ergonomic issues, such as strains and sprains, occur relatively frequently. If one were to assume that the total number of workers’ compensation claims is representative of the cumulative safety risk on a construction site, minor injuries such as strains and sprains would account for a significant portion of risk.

Because appropriate probability and severity scales do not exist for the quantification of construction safety risk, the author has created suggested probability and severity scales. An overview of these scales has been published (Hallowell and Gambatese 2008). The

author of this manuscript refers the reader to this publication as it includes an in-depth discussion of the benefits and limitations of the suggested probability and severity scales as noted by a panel of experts in the field of construction safety and risk management. These scales are briefly presented in Section 2.4.2.5 as they will be used in subsequent sections of this report.

2.3.2. Construction Safety Risks

One of the most important aspects of the safety equilibrium model defined in Manuscript 1 (see Section 1.6.3) is the definition and classification of common construction safety risks. The risk categories represent a significant aspect of both demand and capacity and are the central link for the equilibrium concept. This section reviews the various construction safety risk classifications and involves the selection of safety codes that will be applied to this research.

Three main sources of literature define construction safety accident codes. Each of these accident classification systems (also referred to as codes) is all-inclusive and mutually exclusive. That is, every accident is classified in one, and only one, accident classification code. The Bureau of Labor Statistics defines its yearly construction safety data reports in terms of ten codes (BLS 2002). The Occupational Safety and Health Administration define safety risk classifications in terms of twenty-nine codes in its Occupational Illness and Injury Classification System (OIICS). Each code in OSHA's OIICS is subdivided into more specific categories.

Both OSHA and BLS define accident codes for all industries (i.e., the codes apply to incidents in all industries). Hinze (1998), however, suggests a construction-specific accident classification system that highlights the highest construction-specific safety risks. Using an aggregation of these three accident classification systems, the author has selected 12 all-inclusive and mutually-exclusive codes. The author has incorporated the best features of each of the classification systems and limited the number of codes based

on the parameters and limitations of the research. A summary of the OSHA OIICS codes (2007), BLS Categories (2002), Hinze's construction accident classification system (Hinze 1998), and the selected codes is provided in Table 2.1. Furthermore, the selected codes are defined in the following section.

Table 2.1 – Construction safety risk classifications

OIICS Sub-codes (2007)	BLS Categories (2002)	Hinze's Codes (1998)	Selected codes (Present Study)
Contact with objects and equipment, unspecified	Contact with objects	Struck-by falling materials	Struck-by or against falling objects
Struck against object			
Struck by object		Struck by other materials	Struck against equipment or materials
		Struck-by equipment	
Caught in or compressed by equipment or objects	Caught in or crushed	Caught in/between equipment	Caught in-or compressed by material or equipment
Caught in or crushed in collapsing materials		Caught in/between material	
		Cave-in	
Rubbed or abraded by friction or pressure			
Rubbed, abraded, or jarred by vibration			
Fall to lower level	Fall to lower level	Fall to lower level	Fall to lower level
Jump to lower level			
Fall on same level	Fall on same level	Fall at ground level	Fall on same level (inclusive)
	Slips or trips without fall		
Bodily reaction	Overexertion		Overexertion
Overexertion			
Repetitive motion	Repetitive motion		Repetitive motion
Contact with electric current	Exposure to harmful substance	Electrocution (5-types)	Exposure to harmful substances or environments (inclusive)
Contact with temperature extremes			
Exposure to air pressure changes			
Exposure to caustic, noxious, or allergic substances			
Exposure to noise			
Exposure to radiation			
Oxygen deficiency		Drowning	
		Asphyxiation	
Highway accident	Transportation accident		Transportation accidents (inclusive)
Non-highway accident			
non-passenger struck by vehicle, mobile equipment			
Railway accident			
Water vehicle accident			
Aircraft accident			
Fire		Explosion	Other
Explosion		Fire	
Assaults and violent acts			
Self-inflicted injuries			
Other	All other events	Other	

2.3.2.1. Selected Accident Classification Codes

The accident classification system selected for this study represents an aggregate of three commonly-used accident classification systems as indicated in Section 2.3.2. While the OSHA OIICS was not chosen per se, the OSHA OIICS is extremely well-defined (OSHA 2007). Therefore, the definitions provided by the OIICS will be used to define the ten categories selected. Each of the ten categories is defined below.

2.3.2.1.1. Struck by object

"Struck by object" applies to injuries produced by forcible contact or impact between the injured person and the source of injury when the motion producing the contact is primarily that of the source of injury rather than the person. This category includes incidents where workers are struck by falling objects, struck by flying objects, and struck by swinging or slipping objects.

2.3.2.1.2. Struck against object

"Struck against object" applies to injuries produced by forcible contact or impact between the injured person and the source of injury when the motion producing the contact is primarily that of the injured person. This major group includes: bumping into objects, stepping on objects, kicking objects, and being pushed or thrown into or against objects.

2.3.2.1.3. Caught in or compressed by equipment or objects

This major group includes cases in which the injury was produced when a person or part of a person was injured by being squeezed, crushed, pinched or compressed between two or more objects, or between parts of an object. This category includes 'Caught in or crushed in collapsing materials'.

2.3.2.1.4. *Fall to lower level*

“Fall to lower level” applies to instances in which the injury was produced by impact between the injured person and the source of injury, the motion producing the contact being that of the person, under the following circumstances:

- the motion of the person and the force of impact were generated by gravity, and
- The point of contact with the source of injury was lower than the surface supporting the person at the inception of the fall.

2.3.2.1.5. *Fall on same level*

“Fall on same level” applies to instances in which the injury was produced by impact between the injured person and the source of injury, the motion producing the contact being that of the person, under the following circumstances:

- the motion of the person was generated by gravity following the employee's loss of equilibrium (the person was unable to maintain an upright position) and,
- The point of contact with the source of injury was at the same level or above the surface supporting the person at the inception of the fall.

This category includes slips and trips.

2.3.2.1.6. *Overexertion*

“Overexertion” applies to cases, usually non-impact, in which the injury or illness resulted from excessive physical effort directed at an outside source of injury or illness. The physical effort may involve lifting, pulling, pushing, turning, wielding, holding, carrying, or throwing the source of injury/illness.

2.3.2.1.7. *Repetitive motion*

Repetitive motion applies when an injury or illness resulted from bodily motion which imposed stress or strain upon some part of the body due to a task's repetitive nature.

2.3.2.1.8. *Exposure to harmful substances or environments*

This category applies to cases in which the injury or illness resulted from contact with, or exposure to, a condition or substance in the environment. This category includes contact with electric current, exposure to temperature extremes, exposure to excessive noise, etc.

2.3.2.1.9. *Transportation accidents*

This category includes events involving transportation vehicles, powered industrial vehicles, or powered mobile industrial equipment in which at least one vehicle (or mobile equipment) is in normal operation and the injury/illness was due to collision or other type of traffic accident, loss of control, or a sudden stop, start, or jolting of a vehicle regardless of the location where the event occurred.

2.3.2.1.10. *Other*

This category includes any event or exposure which is not classified or listed under any other division. Also included are fires and explosions, assaults and violent acts, and all other events or exposures not elsewhere categorized.

The ten accident classification codes defined above are used throughout the remainder of this dissertation. As indicated earlier, this classification system is a central component of the equilibrium model and is required to quantify safety risk demand. Before safety risk demand can be defined for the process of constructing concrete formwork, however, the specific activities associated with formwork construction must be identified. The small body of literature related to formwork construction activities is included in the following section.

2.3.3. Formwork Construction Activities

Determining the specific worker activities associated with formwork construction is essential to the population of the theoretical model developed in Manuscript 1. For this

study, the process of constructing concrete formwork is limited only to the on-site construction of formwork elements and does not include the construction of prefabricated items, construction of concrete reinforcement systems, stripping of concrete forms, etc.

While formwork is an extremely common construction process, there is only a small body of literature that explicitly discusses specific activities involved in the construction process. In fact, only one document identified by the author, Formwork for Concrete, published by the American Concrete Institute (ACI 2007) even indirectly defines concrete formwork construction activities. In order to define worker activities from this document, one may only infer from descriptions of design tasks and typical site layouts. Due to the lack of literature on the topic, two research methods were implemented to determine the specific formwork construction activities. These research methods are discussed in Section 2.4.1 and the results of the research effort are presented in Section 2.5.1.

While there is very little literature or available data that defines the specific worker activities required to construct concrete formwork, OSHA tracks the specific high-severity incidents associated with formwork construction (and many other construction processes) in their Accident Investigation Reports. A brief analysis of the archival evidence from 1984 to 2000 is provided in the following section. This information is included despite the fact that the data is only representative of a small proportion of the US construction industry because it may provide insight to the major high-severity safety risks associated with formwork construction.

2.3.4. Formwork Construction Safety Risks

An analysis of the United States' Occupational Safety and Health Inspection Data from 1984 to 2000 indicates that the vast majority of formwork incidents involve falls (61%), struck-by incidents (14.5%), and collapses (6.5%). The author searched the OSHA Accident Investigation Reports, available online at:

<<http://www.osha.gov/pls/imis/accidentsearch.html>>, and found that approximately 2 percent of all construction accidents recorded by OSHA in their incident reports were directly associated with the construction of formwork. Figure 2.2 illustrates the causes of high-severity incidents associated with concrete formwork construction identified in OSHA's archived reports.

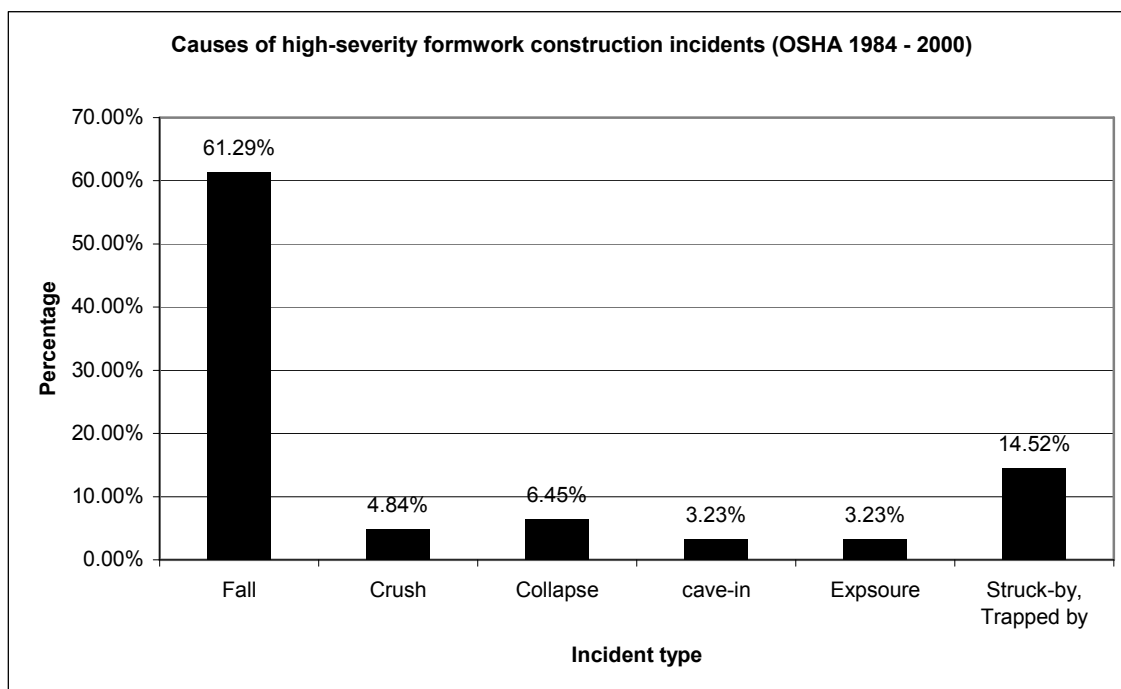

Figure 2.2 – Causes of high-severity formwork accidents

One should note that the author do not believe that the OSHA Investigation Reports are representative of the industry as a whole and that this data would be insufficient for the population for the risk demand model. According to the OSHA website, inspections are only required when an incident results in a fatality or multiple-hospitalization. Even in such cases, OSHA may not officially record and report the results of the accident investigation (OSHA 2007). The variability in the accident investigation occurs because, “There are currently no specific standards for accident investigation.” In many cases, small firms, and governmental organizations that are not under the jurisdiction of

OSHA's inspection team, may choose not to inform OSHA of an incident despite its severity.

The incidents listed on the OSHA website are by no means a comprehensive aggregation of all incidents related to formwork from 1984-2000 as they only include the highest severity incidents. However, the author believes that this data may be an accurate representation of the proportion of causal factors that lead to high-severity formwork injuries. Since the inspection data collected by OSHA represents incomplete industry data and involves only high-severity injuries, the research project from which this manuscript has been written aims to gather improved data that quantifies the probability and severity components of formwork safety risks.

The literature review for this manuscript indicates that there is very little published on the topic of common activities of construction formwork carpenters. Also, there is very little data available that describes the entire spectrum of formwork safety risks. While OSHA tracks some formwork accidents, the reports available online only represent a very small cross section of the entire construction industry. Furthermore, there is no data published on the topic of low-severity, high-probability construction safety risks despite the fact that a true risk analysis incorporates the consideration of an entire spectrum of risks.

The review of current literature provides compelling evidence that the formal quantification of construction safety risk demand is vital to understanding the true construction risk level. The following section will review the methodologies implemented to determine the formwork construction activities and populate the safety risk demand model.

2.4. METHODOLOGY

Several methodologies were implemented to collect data for this study. Due to the complex nature of the research objectives, the methodologies used to determine the worker activities associated with formwork construction are different from the methodology implemented to determine the safety risk demand. This section of the manuscript reviews the methodologies used to determine the formwork construction activities first as this information was used to create the surveys used in subsequent phases of the research. Following a comprehensive review of the Delphi method, the research method implemented to determine the safety risk associated with each activity will be provided. Finally, a discussion of the application of the Delphi method and the specific techniques implemented to minimize judgment-based bias will be reviewed.

2.4.1. Methodology Implemented to Determine Activities Associated with the Construction of Concrete Formwork

Before populating the demand portion of the safety equilibrium model, the specific worker activities associated with a process must be identified. An extensive literature review revealed that there is little published regarding the specific worker activities involved in this construction process. In order to determine the specific activities, the research team decided to conduct field observations in order to identify and classify formwork activities.

Due to the variety of means, methods, technologies, and products implemented by firms, it would be unrealistic to conduct enough observations to create an exhaustive list of possible worker activities with field observations alone. Therefore, the results of the field observations will be used to create surveys that will be sent to seasoned construction professionals for their review. A brief overview of these methodologies is presented below.

2.4.1.1. *Field Observations*

As a primer, the research team conducted field observations of crews that were actively constructing concrete formwork. The specific worker activities and the duration of the activities were recorded. The author believes that recording the duration of activities was important as the durations may provide guidance for organizing specific activities in a manageable list for data collection on subsequent research efforts (e.g., short-listing formwork activities for use in Delphi surveys).

The main objective of the field observations was to create a preliminary list of formwork construction activities. Since this list will be reviewed, augmented, and validated by industry professionals, the author determined that only a modest number of worker-hours of observation were required. Simply, the goal of the field observations was to record specific activities until sufficient repetition was observed. In other words, once the field observer did not continue to observe new worker activities in a 4-hour continuous time period the preliminary list was considered complete. This preliminary list was then used to create a survey form that was sent to industry professionals. The details of this survey are discussed in the following section.

2.4.1.2. *Industry Survey*

As previously indicated, field observations were conducted until the researchers observed substantial repetition. During the field observations, significant repetition occurred after two work days of site observation on two separate projects. The results of these observations can be found in Section 2.5.1. In order to verify and supplement these observations, seasoned construction industry professionals were surveyed and interviewed.

The author determined that the most efficient and effective method of validating and refining the list of formwork activities was to survey and interview individuals with significant construction industry experience with the construction process. Using the data

collected from the field observations, surveys were created and can be found in Appendix B.

The survey was sent to industry professionals in the Northwest Region of the United States. The survey sample is a convenience sample as the respondents were identified from the author's archived contact information. The survey was sent to a target group of ten individuals, each with over 15 years of industry experience constructing and managing the construction of concrete formwork.

Respondents were asked to review the list and description of activities and take one of the following actions: (1) confirm that the list is comprehensive and that nothing is incorrect or incomplete, (2) insert additional activities with a brief description, (3) delete inappropriate activities, or (4) revise the activity titles or descriptions as appropriate. The results of the survey are summarized in Section 2.5.1. The thorough review of the respondents warranted no additional data collection techniques. In the opinion by the author, the review by the seasoned construction experts was sufficiently thorough and resulted in an adequate and representative list of formwork activities.

The following section of this manuscript will provide the reader with a comprehensive review of the major data collection technique implemented for this study. The Delphi technique was used to determine the probability and severity levels for the various safety risks (defined in Section 2.3.2.1) for each construction activity (for a list of activities see Section 2.5.1). Because the Delphi method was the chosen research technique, a thorough review of the origin, techniques, benefits, limitations and applicability to this research will be provided. Additionally, the techniques implemented to minimize judgment-based bias will be discussed.

2.4.2. Methodology Implemented to Quantify Safety Risks Associated with the Construction of Concrete Formwork

The dynamic and transient nature of construction projects makes construction engineering and management research particularly challenging. For example, experimental research on safety, risk management, innovation, and technology forecasting is often unrealistic due to the sensitivity and complexity of these topics. To study such subjects, researchers typically rely on survey and group-brainstorming techniques to collect subjective data. The inherent structure of these studies may involve substantial bias that researchers must recognize and minimize. Therefore, a structured research method that offers researchers the opportunity to control bias and ensure qualification of the respondents is desirable. The Delphi technique, originally developed by the Rand Corporation to study the impact of technology on warfare, allows researchers to maintain significant control over bias in a well-structured, academically-rigorous process using the judgment of qualified experts.

Over the past half-century, the Delphi method has been used extensively in technology forecasting and healthcare research. The method is defined as a systematic and interactive research technique for obtaining the judgment of a panel of independent experts on a specific topic. Individuals are selected according to predefined guidelines and are asked to participate in two or more rounds of structured surveys. After each round, the facilitator provides an anonymous summary of the experts' input from the previous survey. In each subsequent round, participants are encouraged to review the anonymous opinion of the other panelists and consider revising their previous response. During this process the variability of the responses will decrease and group consensus will be achieved. Finally, the process is concluded after a pre-defined criterion (e.g., number of rounds, achievement of consensus, etc.) is met and the mean or median scores of the final round determine the results.

The Delphi method is particularly useful when objective data is unattainable, there is a lack of empirical evidence, experimental research is unrealistic or unethical, or when the heterogeneity of the participants must be preserved to assure validity of the results. Despite its application to construction engineering and management, this well-defined and highly successful research method has not seen widespread use. Therefore, this section of the manuscript will provide the reader with a detailed overview of the research technique and its application.

2.4.2.1. *Overview of the Delphi Method*

2.4.2.1.1. *Overview*

Simply, the Delphi technique is defined as a procedure that obtains consensus of opinion from a group of certified experts using a series of intensive questionnaires. Consensus of opinion is achieved via methods of controlled feedback where simple statistical information that summarizes group opinion is transferred anonymously to expert panel members. That is, panel members are informed of the collective group opinion and are given the option to alter their response during each round. The structure of the technique is such that the positive attributes of interacting groups is exploited while avoiding the negative aspects.

2.4.2.1.2. *Origination*

The Delphi technique was developed during the 1950s by workers at the RAND Corporation. RAND used the technique to collect expert knowledge and judgment to create an optimal U.S. industrial target system for the U.S. Air Force. The first non-military application of Delphi was initiated in a study that focused on forecasting emerging technological events (Gordon and Helmer 1964).

2.4.2.1.3. *Objectives*

The specific objectives of the Delphi Method are as follows:

- Gain insight from a group of certified experts (accuracy)
- Establish a degree of consensus (precision)
- Maintain anonymity of diverse expert panel members throughout the process (unbiased)
- Answer a question that cannot be addressed using standard statistical procedures because of the nature of the question or lack of objective data (judgment)

This research method differs from traditional, simple survey methods in that the respondents are certified as experts according to predefined guidelines before the survey process begins, and consensus is achieved through the use of controlled and anonymous feedback provided by the facilitator during each round. This research technique allows the expert panelists to anonymously interact and allows the facilitator to exhibit strong control over various forms of judgment-based bias.

2.4.2.1.4. *Experimental Units and Output*

As discussed above, one of the fundamental objectives of the Delphi process is to achieve consensus. In classic approaches consensus is defined by the variance in responses (i.e., the spread of responses). The purpose of multiple rounds, in addition to providing controlled feedback, is to reduce the overall variance and achieve greater consensus.

The output of the study is a conclusion that is taken to represent the collective opinion of the experts. This opinion is generally accompanied by the variance to indicate the degree of consensus achieved. In some advanced methods, reasons are included in the feedback process and justification for outliers is provided.

One should note that, in some cases, the convergence of the Delphi panel may not represent consensus but, rather, conformity of the panel. While measures such as anonymity, reporting quartiles, and reasons are taken to achieve consensus, the potential

for conformity is a significant limitation and legitimate point of criticism of the Delphi method.

To combat the potential effect of conformity, there are alternative measures of consensus such as ‘post group consensus’ where panel members are asked to what extent they agree with the final group aggregate. A study performed by Rohrbaugh (1979) compared post-process responses to aggregate responses and found that there was a significant reduction in disagreement for Delphi than other methods such as social judgment analyses and group interaction.

2.4.2.1.5. *Current Status as a Research Technique*

Rowe and Wright (1999) examined research studies that employed the Delphi method and found that it has been used in fields as diverse as healthcare, education, information systems, transportation and engineering. While the method has received harsh criticisms by some authors, the method has been justified by others when objective data is not readily available or when organizing experts in one geographical location is not feasible. Since the mid 1950’s the Delphi method has emerged as an accepted research methodology by the scientific community (Linstone and Turoff 1975).

2.4.2.1.6. *Key Elements of the Delphi Process*

To be classified as “Delphi,” the study requires four key structural elements: anonymity, iteration, controlled feedback, and statistical aggregation. The elements of Delphi are designed to minimize the effects of biasing that result from individual dominance and group pressures for conformity are minimized (Veltri 1985). These elements are introduced below.

Anonymity

First and foremost, contribution of the expert panelists must be anonymous. Anonymity ensures that the negative aspects of group interaction such as social, personal, and

political conflicts are avoided and positive aspects such as knowledge from many sources, information exchange, and creative synthesis are exploited (Rowe and Wright 1999).

Iteration

Studies that employ a single iteration of group responses are classified as ‘statisized groups’. Multiple iterations allow panel members to be informed of the opinions of the other members (anonymously) through a controlled feedback method. Iterations allow panel members to adjust their responses in light of others’ opinions. This structural element is crucial in obtaining any degree of consensus.

Controlled feedback

Feedback is the means by which information is transferred between panel members in a manner that encourages experts to consider one another’s opinions. There are many methods of controlled feedback depending on the nature of the research. For example, feedback may include most common response, degree of certainty, or average rating.

Statistical aggregation of group responses

After the final iteration the group responses are aggregated into one response that represents the collective group opinion. This statistical aggregation is typically manifested through medians, means, or quartiles. More complicated statistical analyses are typically inappropriate given the structure of the method.

2.4.2.1.7. Typical Events

The typical order of events for implementing the Delphi process is summarized in Figure 2.3. This flowchart represents the order of events and illustrates the role of iteration. This structure is common to nearly every Delphi study and was implemented for this project.

Understanding the flow of events will aid the reader in understanding the results obtained from the various rounds (Sections 2.5.3 through 2.5.5).

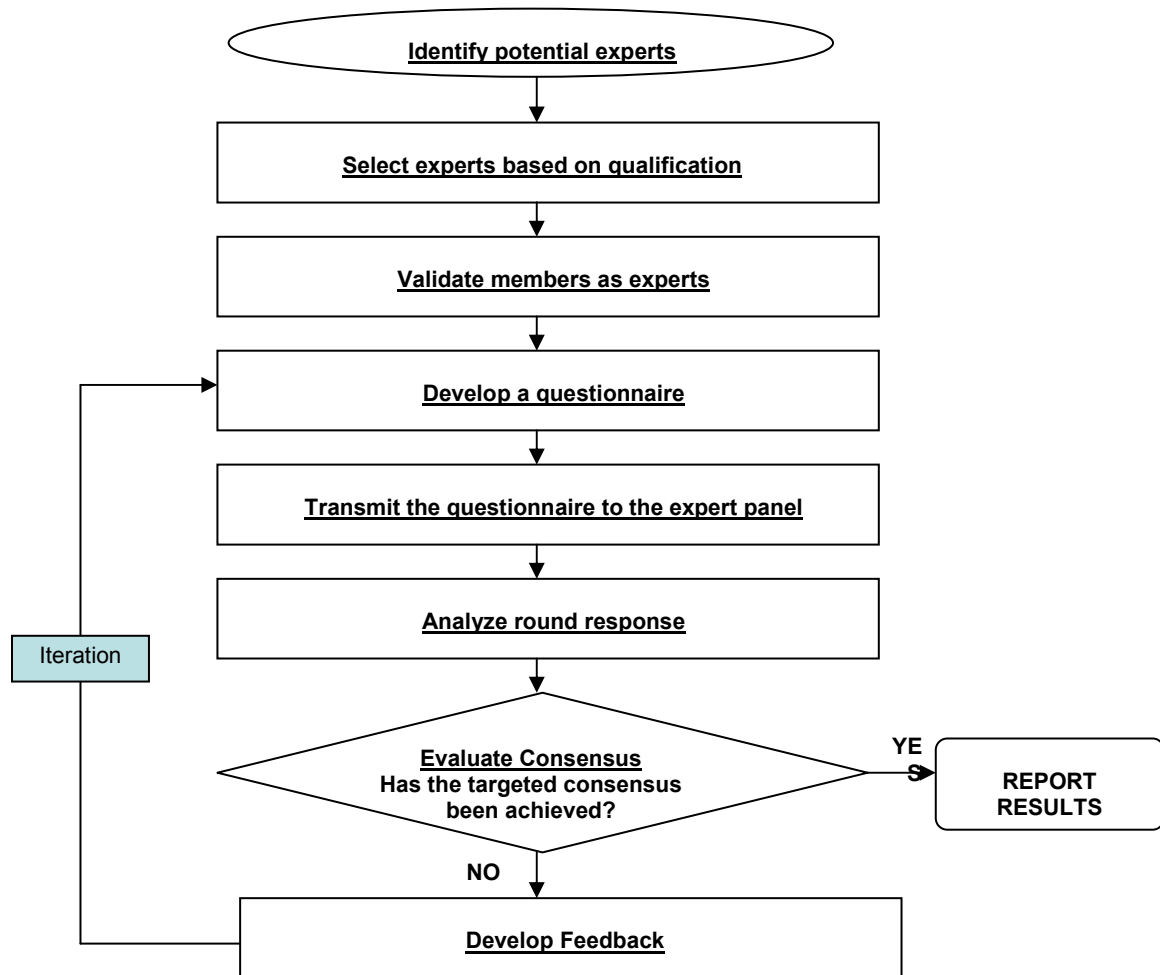

Figure 2.3 - Typical events during the Delphi process

2.4.2.1.8. Variations

Despite the obvious potential for variation in panel size, number of iterations, number of panels, definitions of experts, and other characteristics, the general structure of Delphi remains fairly consistent among peer-reviewed studies. Most major deviations from the generic structure in Figure 2.3 involve the feedback process (McKenna 1994). For example, some studies tend to lead the experts in the first round with objective data or

existing literature. While modification is reasonable in the Delphi process, researchers must take care to maintain the validity and ideals of the original, accepted Delphi process (Chein et al. 1948).

2.4.2.2. *Viability and Applicability of the Delphi Method*

The Delphi method is not an appropriate research technique for all studies. In fact, objective data is almost always preferred over any judgment-based study due to the potential biases and lack of knowledge of the respondents. However, when objective data is unavailable or unattainable, judgment-based studies are an alternative. Delphi represents one of the more rigorous of the judgment-based techniques.

Rowe and Wright (1999) and Rajendran (2006) reviewed the relatively large body of literature related to the support and criticisms of the Delphi technique. The studies that support the use of the Delphi technique are summarized in Table 2.2. This table provides specific supporting comments identified in literature in addition to two supporting notes made by the author.

Table 2.2 – Support for the Delphi method as a viable research technique

Support	Source
Consensus can be achieved in an area of uncertainty or when objective data is unavailable	(Murphy, Black et al. 1998)
Anonymity leads to more creative outcomes and adds richness to data	(Okoli and Pawlowski 2004)
Anonymity and controlled feedback eliminates issues such as dominance, conflict of interest, group pressures, etc. that are commonly associated with expert panels	(Murphy, Black et al. 1998)
Inexpensive to organize and administer	(Rowe and Wright 1999)
Use of modern technologies such as web-surveys and e-mails significantly reduces time required to conduct each iteration	(Rajendran 2006)
Expert opinion from individuals from a variety of geographical locations can be easily obtained	
Bias can be limited by an effective facilitator through controlled feedback and careful analysis of the group response	

As with any research technique, there are critics who identify the limitations of the research method. The Delphi method is no exception. In fact, there are many researchers who criticize Delphi results as being “unscientific” and “limited in quality.” Specific criticisms identified in literature are summarized in Table 2.3. One may note that careful and effective management of the Delphi process is vital as many of the critic’s fault Delphi studies for ineffective management. Therefore, the implementation of the Delphi process for this study was well-structured, careful, and deliberate.

Table 2.3 – Criticism of the Delphi method as a research technique

Criticism	Source
The Delphi technique is unscientific	(Sackman 1974)
Questions that do not seem important at the outset of the project are not asked. Under the traditional method the study does not add additional questions. This can weaken the study considerably.	(Simmonds 1977)
The quality of the research outcomes are limited by the expertise of the panel members	(Martino 1978) as cited in (Veltri 1985)
Convergence of collective opinion may be confused with conformity	(Rowe and Wright 1999)
Participant commitment may falter if the process is too long and the panelists may suffer fatigue from completing more than two rounds.	(Adler and Ziglio 1997)
The results can be limited by the quality of the facilitator's survey instruments and techniques such as: sloppy execution, poor choice of experts, unreliable analyses, and limited value of feedback and instability of responses.	(Gupta and Clarke 1996)
Bias can occur if questions lead or a poorly worded or if the results are interpreted selectively.	(Lang 1998)
The typical Delphi procedure can be time intensive and requires significant maintenance	(Rajendran 2006)

As discussed previously, the Delphi method is intended to be used when objective data cannot be realistically or readily obtained. That being said, there are only a few major group alternatives to Delphi. Several of these alternatives are described and compared to Delphi in the following paragraphs.

Staticized groups

The staticized groups research method is identical to the Delphi method except that it does not include feedback or iteration. That is, the method represents the aggregate

responses of certified experts from initial questioning. Therefore, there is no interaction between panel members. While some studies such as Erffmeyer et al. (1984) justify using this method over Delphi (because panel members cannot conform), Rowe and Wright (1999) found that literature supports Delphi as the preferred method twelve peer reviewed studies to two.

Interacting groups

This method, otherwise known as ‘focus groups’, involves collecting experts in one physical location, via teleconference or other modern methods of virtual meetings where experts can communicate with one another in real time. In this method the panel members are not anonymous. In Rowe and Wright (1999), Delphi was found to be superior five peer reviewed studies to one. The main pitfall of interacting groups is the potential for bias due to dominance.

Nominal group technique (NGT)

The Nominal Group Technique is also referred to as ‘estimate-talk-estimate’ or ‘Brainstorming NGT’. The NGT procedure uses the Delphi process except that feedback is delivered through face-to-face meetings and discussions between rounds. This method has been proven effective in expediting the data collection procedure but often results in significantly more biased results and conformity (Erffmeyer and Lane 1984). This method is also difficult to conduct because it requires the collection of experts in one geographical location.

Figure 2.4 depicts the relationships between the four group data collection techniques. As one can clearly see, the Delphi method involves both low informant-informant communication and low intensity of researcher-informant communication. It is because of this low intensity-communication that certified experts and a structured feedback mechanism are so important. The low levels of interaction allow the researcher to exhibit great control over the process thereby minimizing bias.

Nominal Group Technique (NGT)	Interacting Groups (a.k.a Focus Groups)	High Intensity of Informant- informant communication
Group Interview (NGT)	DELPHI	
High Intensity of Researcher-Informant Low Communication		Low

Figure 2.4 – Relationships between group-data collection techniques (Erffmeyer and Lane 1984)

2.4.2.2.1. *Appropriate Application of the Delphi Method*

Rajendran (2006) identified and summarized many scenarios where Delphi has been found to be the preferred research method. This summary includes an exhaustive review of the literature and is as follows:

- “Disagreement may exist among the experts to the extent that a referred communication process is desired (Towne 1967, as cited in Veltri 1985).
- The opinion of a group is more desirable than the opinion of a single expert (Pill 1971, as cited in Veltri 1985).
- It is desired that the psychological aspects of face-to-face confrontation be minimized (Pill 1971, as cited in Veltri 1985).
- Questions to be answered by intuitive judgment supersede questions to be answered by concrete measurement (Pill 1971, as cited in Veltri 1985).

- The problem does not lend itself to precise analytical techniques, but can benefit from subjective judgments on a collective basis (Linstone and Turoff 1975).
- The individuals needed to contribute to the examination of a broad or complex problem have no history of adequate communication and may represent diverse backgrounds with respect to experience or expertise (Linstone and Turoff 1975).
- More individuals are needed than can effectively interact in a face-to-face exchange (Linstone and Turoff 1975).
- Time and cost make frequent group meetings infeasible (Linstone and Turoff 1975).
- The efficiency of face-to-face meetings can be increased by a supplemental group communication process (Linstone and Turoff 1975).
- Disagreements among individuals are so severe or politically unpalatable that the communication process must be refereed and/or anonymity assured (Linstone and Turoff 1975).
- The heterogeneity of the participants must be preserved to assure validity of the results, i.e., avoidance of domination by quantity or by strength of personality ("bandwagon effect") (Linstone and Turoff 1975).
- Combining views to improve decision making is desired (Bass 1983).
- Immediate confirmation of the results is not possible (Veltri 1985).
- The research is contributing to an incomplete state of knowledge (Delbecq et al. 1975).
- There is a lack of empirical evidence (Murphy et al. 1998)."

As one can see, Delphi is a preferred judgment-based research technique that can be used in a rigorous research study when objective and empirical means are not feasible. While

Delphi is appropriate for many complex studies, there are many applications of Delphi that would be inappropriate.

The Delphi method is inappropriate when the general recommended structure is not followed, when the ideals of the process are violated, when objective data is available, and when the facilitator's ignorance leads to misinterpretation of results. For example, the Delphi method is not appropriate when the method is applied for a purpose other than achieving the consensus of a group of experts (Pill 1971), when the feedback mechanisms are such that the real experts are diluted by the aggregation of responses by less qualified (less 'expert') members (Veltri 1985), or when the structure of the study is such that conformity is encouraged.

2.4.2.2.2. *Applicability of Delphi for this Research*

Delphi is a procedure that is intended for use when objective data and pure statistical methods are not practical and when judgment and forecasting methods become more practical (Wright et al. 1996). Many studies have indicated that the Delphi panel is significantly more accurate than initial, pre-procedure aggregates (statisized groups) and judgments or forecasts achieved in interacting groups (Best 1974; Larreche and Moinpour 1983; Erffmeyer and Lane 1984).

The following figure (Figure 2.5) lists several characteristics of this study and the corresponding applicability of the Delphi procedure. For each research characteristic, justification for choosing the Delphi method is provided. Each justification is accompanied by supporting literature where appropriate. One should note that in many cases other group methods may also be justified. However, the previous section of this report provides evidence, in all cases, that the Delphi method is preferable.

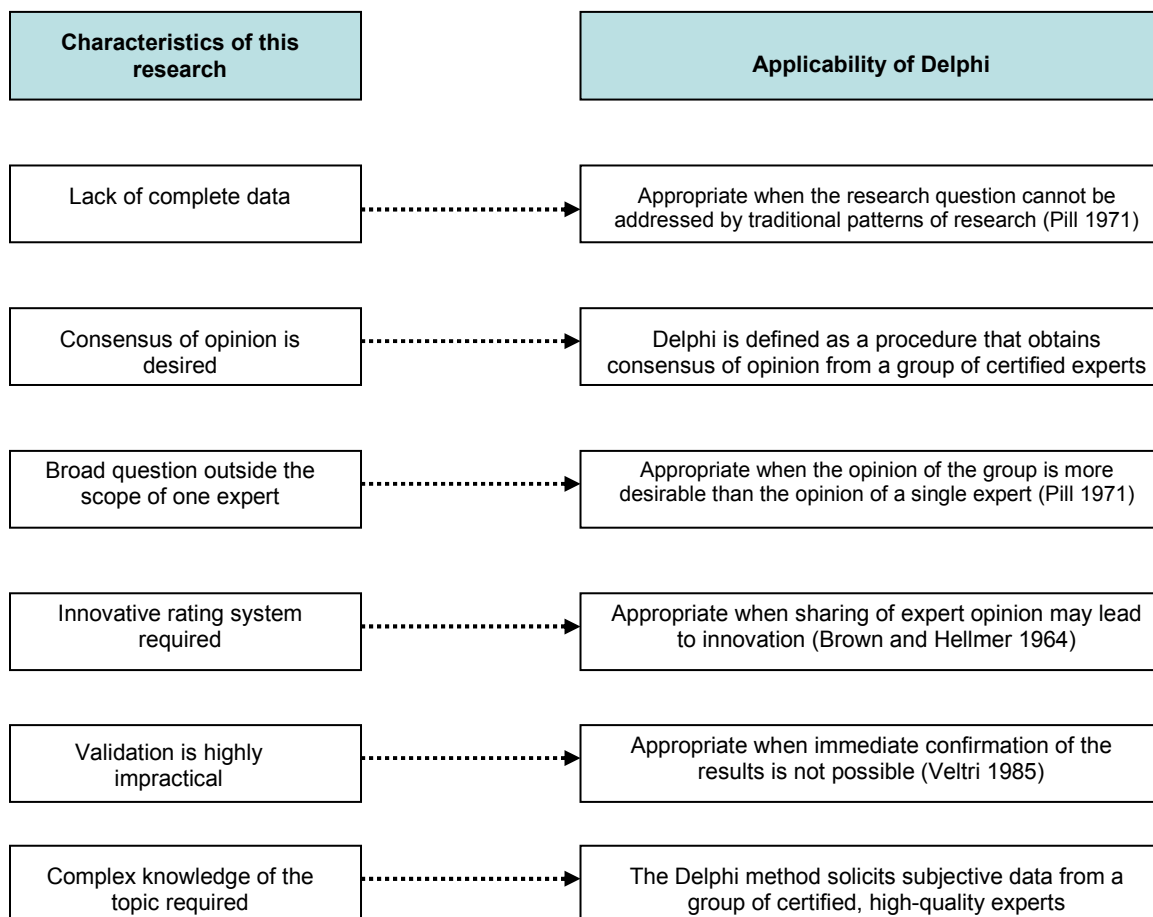

Figure 2.5 – Applicability of the Delphi method for this research

2.4.2.3. *Forms of Judgment-Based Bias*

Judgment is a skill that is used in decision making when disputable factual information is absent. Because the data obtained through the Delphi method is judgment-based, a rigorous and defensible research study must identify and minimize all forms of judgment-based bias. One or more of three classes of judgment are used to reason and eventually make choices by the expert panelists during the Delphi process. These three classes are defined as follows (Sillars 2006):

Diagnostic

Diagnostic judgment involves using intuition, visualization, organization, and structuring of evidence and the understanding of relationships to reach a conclusion.

Inductive

Inductive reasoning requires the synthesis of evidence and information from a variety of sources. Inducing requires use of an individual's awareness of signs and evidence to draw conclusions. The ability to draw correct conclusions using inductive reasoning is directly related to an individual's experience, observations, and ability to recognize evidence.

Interpretive

Interpretive reasoning involves the recognition of patterns, spatial relationships, correlations and causal relationships. Individuals who can effectively reason through interpretation must be able to critically review, evaluate, and develop context for a particular scenario.

In a Delphi study, it is assumed that identified experts are uniquely capable of providing expert judgment using one or more of the three reasoning methods identified above. One should note, however, that various sources of bias may exist. Much has been published on the topic of biases in decision making from a social psychology standpoint. Several biases that are particularly applicable to the proposed research will be reviewed.

Bias is defined in this manuscript as any factor that distorts the true nature of an opinion or observation. Bias in judgment is important to consider because the effects from cognitive shortcuts can lead to inaccurate results (Heath, Tindale et al. 1994). In this study, the structure of the Delphi procedure was designed in such a way that the impacts of decision making bias are reduced and eliminated whenever possible.

The following sections are provide an overview of seven types of bias that are applicable to this study. These types have been selected because of their potentially negative impact on the ability of the panelists to accurately quantify the probability or severity of construction safety risks. These factors are not necessarily controlled when following traditional guidelines for Delphi implementation.

2.4.2.3.1. *Collective Unconscious*

Simply, the theory of collective unconscious, otherwise known as the “bandwagon effect,” states that decision makers tend to join a popular trend. In other words, individuals are likely to unconsciously feel pressure to conform to the common or standard beliefs within a particular group. According to Emilie Durkheim (1982), individual beliefs are limitless unless constrained or directed by social forces such as peer pressure or dominance. The bandwagon effect occurs when social forces compel an individual to conform.

The collective unconscious must be considered in a Delphi study because bias occurs when a decision maker conforms to popular belief without examining the merits of the position. Researchers in many fields have reported this observation including social psychology (Gilovich 1991) and innovation (Lee and Chan 2003).

2.4.2.3.2. *Contrast Effect*

The contrast effect occurs when the perception of a given subject is enhanced or diminished by the value of the immediately preceding subject. Bjarnason and Jonsson (2005) contend that an individual’s evaluation of a criterion (e.g., risk) may be directly influenced by a previous exposure of substantially higher or lower value. For example, a subject’s response to a question regarding their support for abortion was found to be significantly influenced by the presence or absence of a preceding question regarding the abortion of deformed fetuses (Shuman and Presser 1981).

In theory, the contrast effect can cause significant bias in this risk quantification study, especially when Delphi panel members are asked back-to-back questions regarding risks of substantially different values. Therefore, the structure of the Delphi questionnaire must be such that bias from contrast effects is minimized.

2.4.2.3.3. *Neglect of Probability*

There are many cases where individuals underestimate the role of probability in the subjective quantification of risk. This bias involves the disregard of likelihood when making a decision under uncertainty. For example, Rottenstreich and Hsee (2001) found that while the average individual was willing to pay \$7 to avoid a 1% chance of a painful electric shock, the same individuals were only willing to pay \$10 to avoid a 99% chance of the same shock. Clearly, the subjects have devalued the concept of probability in this scenario.

Since this proposed study involves the quantification of risk and, therefore, elements of probability, it is essential to provide controls that eliminate this bias. Controls are especially important because researchers suggest that the neglect of probability is relatively common (Martin 2006).

2.4.2.3.4. *Von Restroff Effect*

The Von Restroff Effect was first introduced to the field of psychology by Hedwig von Restroff. In his study, subjects were found to recognize and remember relatively extreme events more often and more accurately than less extreme events (Restorff 1933). Simply, individuals are more likely to remember events associated with a high magnitude of severity thereby distorting the perception of probability.

This phenomenon is likely to cause bias because more extreme events are likely to be recalled. It is especially important to consider this bias when soliciting risk perceptions

because individuals are more likely to overestimate probability values when an especially high magnitude is involved (Krimsky and Golding 1992). This effectively creates an artificially-inflated risk score for potential events associated with a higher level of severity.

2.4.2.3.5. Myside Bias

According to Perkins (1989), myside bias occurs when an individual generates arguments only on one side of an issue. Perkins provided a demonstration of this bias by asking subjects to list the thoughts that come to them when considering controversial subjects. The majority of subjects recorded thoughts that pertained to only one side of the controversy. According to (Baron 2003), subjects can be, “easily prompted for additional arguments on the other side, although prompting for further arguments on their favored side is less effective. So the failure to think of arguments on the other side is typically not the result of not knowing them.”

The persistence of irrational belief is generally a result of one’s personal opinion and has little basis in pure fact. This phenomenon also exists when uncompromising individuals do not seek objective viewpoints. Myside bias is especially important to consider in Delphi studies because the chief objective is to reach consensus among the experts. Therefore, controls that ensure the consideration of multiple viewpoints are essential.

2.4.2.3.6. Recency Effect

The reasoning behind the recency effect is that subjects are more likely to artificially inflate risk ratings when similar incidents have recently occurred. That is to say, recent events are given inappropriate levels of salience in relation to others. The effect of recency is relatively common. Take, for example, a cyclist who has recently been involved in an accident. This cyclist is more likely to provide a higher risk rating for a bicycle crash than a cyclist who has not been involved in a crash for several years. While

recency is relatively difficult to control for, one method is suggested by this author later in this paper.

2.4.2.3.7. Primacy Effect

The primacy effect is a relatively subtle form of cognitive bias. This effect results from the unconscious assignment of importance to initial questions, observations, or other stimuli. The theory behind this bias is that individuals are inherently more concerned with initial stimuli. That is, relatively speaking, the first stimulus will be considered more important than the final observation. In terms of the proposed study, an individual is more likely to assign importance to a risk scenario at the beginning of a Delphi survey than at the end. As with all other biases listed above, one must provide control whenever possible.

The seven factors described above represent the salient biases that apply to this study. One must recognize that there are hundreds, if not thousands, of biases that have been identified in the fields of psychology and social science. However, it is the opinion of this author that controlling for the above biases is sufficient for the purpose of this study. Section 2.4.2.4.7 defines some methods for designing the proposed Delphi study to minimize and avoid bias.

2.4.2.4. Design of the Delphi Method

This section of the manuscript will discuss the specific design of the Delphi process for this study. The design of the Delphi study will incorporate the findings of the literature review and will aim to minimize bias, and achieve the highest quality results.

2.4.2.4.1. Expertise requirements

The most important characteristic of Delphi panel members is expertise. The characteristics required to define an individual as an ‘expert’ is equivocal. As in nearly all studies, a major objective is to obtain an unbiased, representative sample. Therefore, the

method of selecting expert panel members should be strategic and unbiased. Three studies provide explicit guidance for qualifying individuals as experts.

Rogers and Lopez (2002) suggest that all expert panel members meet at least two the following requirements:

1. Authorship
2. Conference presenter
3. Member or chair of committee
4. Employed in practice or supervisor with five years of experience
5. Employed as a faculty member with specific interest in the research area

Veltri (1985) suggests more flexible guidelines and suggests that panel members meet one of the following criteria:

1. Demonstration of knowledge which members of recognized professions and society at large judge as being of expert quality.
2. Exhibition of expertise by willingly submitting for critical examination, various publications related to the discipline involved.
3. Participation in professionally related forums, conferences, and workshops with colleagues interested in advancing the related profession.

Finally, Rajendran (2006) aggregated these expert characteristics and suggested requiring that individuals meet at least three of the above eight requirements to qualify for the study. While these publications provide explicit guidance it is clear that the specific requirements (e.g. number and nature of publications, presentations, committee, etc.) must be tailored to the specific research effort.

The expertise requirements for this study are based, in part, on the studies of Rajendran (2006), Veltri (1985), and Rogers and Lopez (2002). For this study, an individual must meet at least **four** of the following eight characteristics:

1. Primary or secondary author of at least three peer-reviewed journal articles on the topic of construction safety or health
2. Invited to present at a conference with a focus on construction safety or health
3. Member or chair of a construction safety and health-related committee
4. At least 5 years of professional experience in the construction industry
5. Faculty member at an accredited institution of higher learning with a research or teaching focus on construction safety and health, or risk management
6. Author or editor of a book or book chapter on the topic of construction safety and health, or risk management
7. Advanced degree in the field of civil engineering, construction engineering, occupational safety and health, or other fields directly related to this study, from an institution of higher learning (minimum of a BS)
8. Designation as a Professional Engineer (PE), Certified Safety Professional (CSP), Associated Risk Manager (ARM), or a Licensed Architect (AIA)

2.4.2.4.2. *Number of Panel Members*

The impact of the number of panelists on the accuracy and effectiveness of the method has been studied by Brockhoff (1975) and Boje et al. (1982). Neither study found a significant correlation between the number of panel members and effectiveness. A summary in Rowe and Wright (1999) indicates that the size of a Delphi panel has ranged in peer-reviewed studies from a low of three members to a high of eighty. Likewise, the number of Delphi panels analyzed ranged from one to four panels with the vast majority of Delphi studies containing only one panel. No study reviewed showed a significant correlation between the number of members on a panel or the number of panels to the accuracy or validity of the process.

As previously indicated, there has been a significant variation in the number of members in each Delphi panel. Characteristics of the study such as the number of available experts,

the desired geographic representation, and capability of the facilitator limit the number of panel members that is reasonable. Based upon the judgment of the author and the availability of certifiable experts, the author has aimed to create two independent panels of eight to fifteen members each.

2.4.2.4.3. *Feedback Process*

As indicated earlier in this document, the feedback process is the mechanism that informs panel members of the opinions of their anonymous counterparts. Without iterating and providing this controlled feedback, the process could not be called, “Delphi.” A study performed by Rowe and Wright (1999) reviewed the body of peer reviewed literature regarding Delphi studies and reported on the various techniques. In this report there is a significant variation in the feedback process.

The most common feedback provided in subsequent iterations is simple statistical summaries such as median, mean, or quartile ranges. Some studies provide additional information such as the arguments from the panel members whose opinions are outside the interquartile range (middle 50 percent). Including anonymous justification for outlying observations ensures that all opinions are considered.

Best (1974) found that Delphi groups that were given reasons as part of the feedback in addition to median and range of estimates were significantly more accurate than Delphi groups that were provided with only the latter. Despite conflicting evidence in social psychology regarding the influence of various feedback methods on accuracy, conformity, change in opinion, and consensus (Deutsch and Gerard, 1955; Myers, 1978; Isenberg, 1986), Delphi studies that included reasons and simple statistical summaries lead to more accurate results (Rowe and Wright 1999).

Classical Delphi approaches suggest reporting median, means, and variance as feedback for each iteration. Most studies indicate that this information is sufficient for promoting

progress toward consensus. However, a few recent studies have shown evidence that soliciting and sharing reasons for outlying observations improves accuracy (Rowe and Wright 1999). Based on this evidence, reasons in addition to simple statistics (i.e., median values and absolute deviations) will be reported in the form of controlled feedback.

2.4.2.4.4. *Survey Instrument*

Traditional Delphi instruments utilize traditional mail surveys for data collection. The facilitator commonly organized a set of open ended or structured questions for the first round and solicited responses. With the technology available today, this method is relatively cumbersome. In the twenty-first century several mechanisms are more viable such as internet-based surveys, e-mail, and facsimile. These instruments allow for a substantial reduction in time required to complete the study and increase the efficiency of the process.

E-mail will be used for this study as it is the most convenient form of data collection for both the facilitator and the panel members. Other methods such as traditional mail and facsimile will also be offered as an option.

2.4.2.4.5. *Number of Iterations*

The purpose of multiple rounds is two-fold. The main objective is to reach consensus (accuracy) by reducing variance in responses. The second purpose is to improve precision. Both of these objectives are achieved through the use of controlled feedback and iteration. It is assumed, and supported by literature, that convergence to a collective opinion and precision (i.e. “closeness” to actual state) are improved as a result of each round. However, literature provides very little guidance for the appropriate number of iterations. A summary of peer reviewed Delphi studies indicates that the number of

rounds ranged from two to six. Over half of these studies found acceptable convergence after three or fewer iterations.

Due to the lack of consensus in the literature regarding the number of iterations required to reach acceptable consensus, the most common will be used. As was reported previously, over half of the peer-reviewed studies found acceptable consensus after three or fewer rounds. Therefore, the target number of rounds for this study is three.

2.4.2.4.6. *Measuring Consensus*

One of the more difficult aspects of the Delphi process to identify, is the appropriate method of measuring consensus. While it is common to use variance as a measure of consensus, guidance that describes the value of variance that represents “consensus” is not available in literature. The author believes that such guidance is not provided because the data collected for nearly every study is unique. Therefore, it would be inappropriate to indicate a certain value of variance that represents adequate consensus.

Given the structure of the Delphi surveys (Appendix A), the author believes that adequate consensus for this study would occur when the absolute deviation (a measure of variance) is 1 unit on a 1 to 10 scale. In other words, the author targets an absolute deviation of 1 probability or severity unit on the provided scales. Further discussion of this scale will be provided later in this manuscript.

2.4.2.4.7. *Controls Implemented to Minimize Judgment-Based Bias*

As previously discussed, one of the primary objectives of the Delphi design is to minimize judgment-based bias. One of the techniques to minimize bias that is implemented in a variety of ways in this study is randomization.

In the field of statistics, the most prominent method of bias reduction is the use of randomization. Randomization is a control by which a researcher ensures that every

subset of the greater population has an equal chance of being selected. Randomization may be achieved through the use of workbooks with random number tables, using the last four digits in telephone directories, or by using a pseudo-random number generator such as MS Excel. For this study, randomization will be used to reduce bias associated with the contrast effect, the Von Restroff effect, and the primacy effect. The remaining four biases will be controlled by the strategic design of the survey and feedback mechanisms. Table 2.4 provides the reader with a summary of controls that will be implemented in the proposed study and how they limit each form of judgment-based bias identified in Section 2.4.2.3. A short description of each of the seven controls is provided below.

1. *Randomization of questions in the survey:* The order of questions in the Delphi surveys will be randomized for each Delphi panel member. A new randomized order will be created for each round. Random numbers will be generated for each question. The ranks of these numbers will be used to determine the order that questions will appear.
2. *Random allocation of Delphi panel members to each Delphi group:* As indicated in the proposal, two Delphi panels will be used for this study. Expert jurors will be randomly assigned to one panel using a random number generator. Individuals with ranks over the fiftieth percentile will be allocated to one group while those with ranks below the fiftieth percentile will be in the other.
3. *Including reasons in controlled feedback:* Best (1974) found that Delphi groups that were given feedback of reasons in addition to median and range of estimates were significantly more accurate than Delphi groups that were provided with only the latter. In addition to probability and severity ratings, expert panel members will be asked to provide a very brief justification for their ratings. This justification will be summarized and reported as part of the controlled feedback.

4. *Iteration*: Iteration is an essential component to any Delphi study. In Delphi studies the primary role of iteration is to achieve a high degree of consensus among panel members. The potential reduction in bias is rarely discussed. Iteration involves the redistribution of the Delphi survey accompanied with controlled feedback (i.e. simple statistical summaries of the responses).
5. *Survey structure*: Surveys will be structured such that panel members will be required to enter probability and severity values separately for each risk scenario.
6. *Reporting results*: Results will be reported using the medians and variance associated with the probability and severity for each risk scenario.
7. *Identification of recent events*: In the introductory survey Delphi members will be asked a series of questions related to their recent experience with construction accidents. Respondents who indicate recent exposure will be monitored during the Delphi process. If the individual appears to be affected by recency bias, the results may be omitted using statistical justification.

Table 2.4 - Controls for bias in the Delphi process

Bias	Control/Countermeasure
Collective Unconscious	Include reasons in the controlled feedback to the Delphi panel for each iteration
Contrast Effect	Randomize the order of questions for each panel member
Neglect of Probability	Require that the probability ratings and severity ratings for each risk are recorded independently
Von Restroff Effect	Randomization of the Delphi panel group, including reasons in controlled feedback and iteration in the Delphi process
Myside Bias	Include reasons in the controlled feedback to the Delphi panel for each iteration, reporting final risk ratings as a median
Recency Effect	Identification of individuals who have experienced recent events, removal of outlying observations, iteration, reporting results as a median
Primacy Effect	Randomize the order of questions for each panel member

This section has provided an overview of the role of judgment in the Delphi technique, seven sources of bias that commonly occur in decision making, and seven controls that will be implemented on the proposed study to minimize the potential effects of these biases. This overview is intended to serve as a guide for effective Delphi implementation and will be used to design the proposed Delphi study.

2.4.2.5. Risk Quantification Scales

As reviewed in literature in section 2.3.1, risk quantification requires the independent quantification of probability and severity. The product of probability and severity provides an individual with a unit risk level (i.e., risk per worker-hour). Multiplying this value by exposure (i.e., worker-hours) provides one with a cumulative risk value defined in terms of severity. Because the objective of this research is to define the unit risk values for constructing formwork in the construction industry, not on a specific project, the exposure values are irrelevant during the data collection process. The following sections will review the probability and severity scales that will be used for this study.

2.4.2.5.1. Probability

As presented in Section 2.3.2, many risk quantification methods ignore high probability, low-severity incidents. For this reason the author believes that a continuous scale that encompasses a large range of potential probabilities (defined in terms of worker-hours) is most appropriate. The probability scale shown in Table 2.5 is proposed by the author. This scale incorporates all levels of probability from zero to incidents that may occur once every six minutes per worker. The scale incorporates the use of incident rates by using incidents per worker-hour. Each probability level (from 1 to 10) is separated by a power of ten. This large range of probabilities allows one to include all types of incidents when calculating cumulative risk.

For this study the chance component of risk will be described in terms of probability. However, one should note that the scaled values of probability will be referred to in terms

of incident rates (i.e., frequency). The author determined that individuals are comfortable with the concept of incident rates. Therefore, the Delphi panelists will be asked to rate frequency in terms of worker-hours per incident. This frequency can later be converted to a probability. For example, if the frequency level was rated as 100 worker-hours per incident one could determine that the probability that one worker would be injured during one hour of work would be 1/100 or 1%. The reader should be conscious of this frequency to probability conversion throughout this document.

For reference, data published by the BLS in 2005 indicates that the US construction industry accounted for 1,186 fatalities and 414,900 lost work-time incidents (not including fatalities). Also, in 2005, the construction industry employed approximately 7,336,000 workers, each averaging 38.6 hours of work per week. This results in a total of 14.7 billion worker-hours. Using this information we can easily calculate that the average number of worker-hours per fatality was approximately 12.5 million worker-hours per fatality and 35,490 worker-hours per lost work-time injury. As one can see, the proposed probability scale includes these values and allows for the inclusion of incidents of higher probability.

A major benefit of this scale is the ease of use relative to other methods of quantifying probability. Determining exact probability values for high-probability risks such as minor musculoskeletal injuries related to ergonomics would require detailed recordkeeping on behalf of the employer. Though it may be possible to calculate close approximations of these values within individual firms, defining the industry-wide probability values for various incidents would be very difficult. Using their years of experience, construction experts should be capable of determining the approximate range for both their firms and the industry as a whole.

Table 2.5 - Proposed probability scale

Incident rate	Probability Score
Impossible	0
Negligible	1
10-100 million worker-hours	2
1 to 10 million worker-hours	3
100,000 to 1 million worker-hours	4
10,000 to 100,000 worker-hours	5
1,000 to 10,000 worker-hours	6
100 to 1,000 worker-hours	7
10 to 100 worker-hours	8
1 to 10 worker-hours	9
0.1 to 1 worker-hour	10

2.4.2.5.2. *Severity*

Based on the descriptions provided in Section 2.3.1.2 and the references cited above, a continuous scale (shown in Table 2.6) has been produced that captures both high severity injury types such as lost work-time injuries, disabling injuries, and fatalities, and low-severity injuries such as temporary discomfort, temporary pain, and persistent pain. The risk scores and descriptions have been modeled after the descriptions in Hinze (1997), Hill (2004), the Canadian Organization of Oil Drilling Contractors (2004), and the Occupational Safety and Health Administration (2007). The spectrum of all possible injury types is included in this scale.

Initially, the author produced a linear scale that rated the impact (i.e., severity) of the various injury types on a 1-10 scale. However, after close examination of literature, it was apparent that the impacts were not linear. For example, the difference in impact between a fatality and a disabling injury is significantly greater than the difference between a major first aid injury and a minor first aid injury. Given this non-linear relationship the author created an adjusted scale.

The impetus for the adjusted severity scale came from notes in literature that claim that the difference in impact between disabling injuries and fatalities is not the same as the difference between other severities on the scale. Specifically, previous research (Soloman and Abraham 1980; NIOSH 1999; Baradan and Usmen 2006) indicates that the severity of a fatality should be valued at twice that of non-fatal injuries. In other words, these publications suggest an inflation factor of 2 for fatalities when conducting a risk analysis. This inflation factor and other relationships among severity types will be reviewed in detail with the goal of producing a representative severity scale.

The author suspects that the inflation factor of 2 used by Barandan and Usmen (2006) may be an underestimate, especially if risk is defined in terms of monetary costs. In 2007, the NSC estimated that the cost per death was \$1,190,000 and the cost per disabling injury was \$38,000. These figures represent the sum of the estimated wage loss, medical expenses, administrative expenses, and employer costs but exclude property damage. If one were to use this data to calculate an inflation factor, the value in 2007 would be approximately 31 ($\$1,190,000 / \$38,000 = 31.3$). Figure 2.6 illustrates the ratio of estimated fatality cost to the estimated cost of a disabling injury using the NSC data published from 1998 to 2007. The NSC *Injury Facts 2007* defines “disabling injury” to include those in which the injured person is unable to effectively perform their regular duties or activities for a full day beyond the day of the injury. This includes the lost work-time and medical case severities shown in Table 2.6. Therefore, the inflation factor of 32 should be multiplied by 8 to get a risk score of 256 for fatalities.

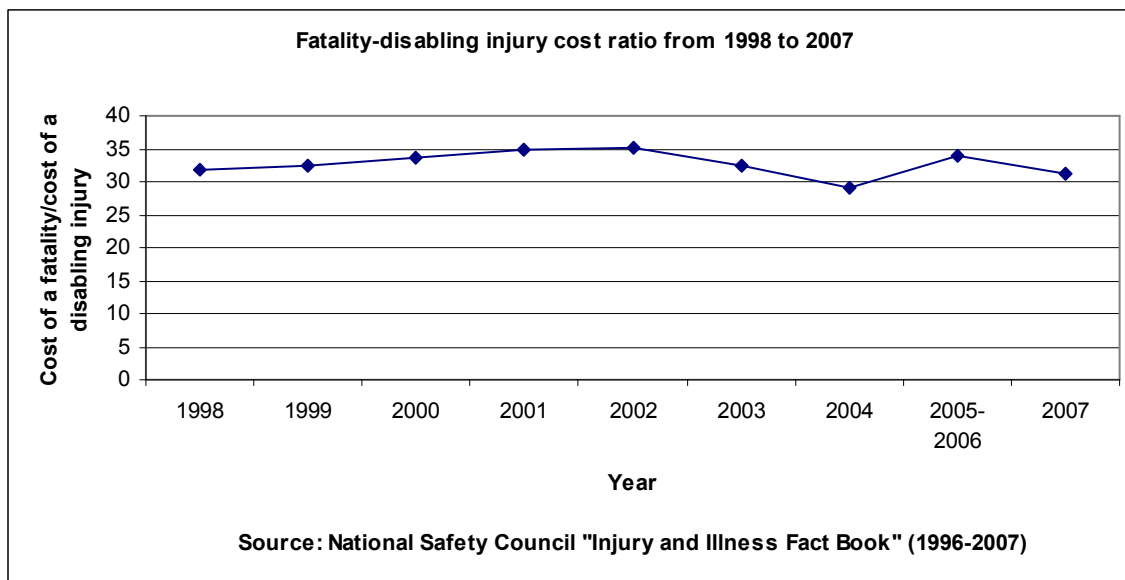

Figure 2.6 - Fatality-disabling injury cost ratio from 1998 to 2007

Based on literature that provides dollar values associated with injury severity levels, the author hypothesized that the true severity between severity levels follows a geometric pattern with a starting value of 1 and a common ratio of 2. This claim was confirmed by the two main data sources (The National Safety Council (2006) and Davidson (2000)) that present estimated dollar values for various injury severity types. An analysis of this data provides supporting evidence that the true impact of the various severities is well-represented by the geometric series hypothesized by the author. This data is summarized in Table 2.6 and visually depicted in Figure 2.6.

One should note that two breaks in the geometric series exist. First, the difference between fatalities and disabling injuries is 256 units as discussed earlier in this section. Second, the data suggests that the ratio between permanent disablements and medical case injuries is, in fact, a value of 4. The ratio between all other severity types is 2.

By reviewing Figure 2.7 and Table 2.6, the true relationship among the severity levels is not linear. Rather, the scale should be listed in terms of a geometric sequence with a ratio

of two as proposed. The revised severity scale with original values, adjusted scores, and descriptions of each severity level is provided in Table 2.7.

Table 2.6 – Dollar values associated with injury severity levels

	Proposed	NSC (2006)	Davidson (2000)
Near miss	0	\$0	\$0
Negligible	1	\$0	\$2,200
Temporary discomfort	2	\$50	
Persistent discomfort	4		
Temporary pain	8		\$24,400
Persistent Pain	16	\$100	
Minor first aid	32		
Major first aid	64	\$500	
Lost work-time	128	\$2,000	
Medical Case	256	\$20,000	\$50,400
Permanent Disablement	1024	\$50,000	\$201,100
Fatality	26214	\$250,000	\$300,000

One should note that the incorporation of the adjusted severity scores in Table 2.7 was done after the scales were implemented during the Delphi process. Therefore, the values in the severity scale in Table 2.7 are not completely consistent with the scales provided on the Delphi survey forms (Appendix A). However, one should note that the data analysis incorporates the scales *provided to the Delphi only*. The revised scales are provided here as the author believe that they are superior to those provided to the Delphi panel in this study and should be incorporated into future safety risk management studies.

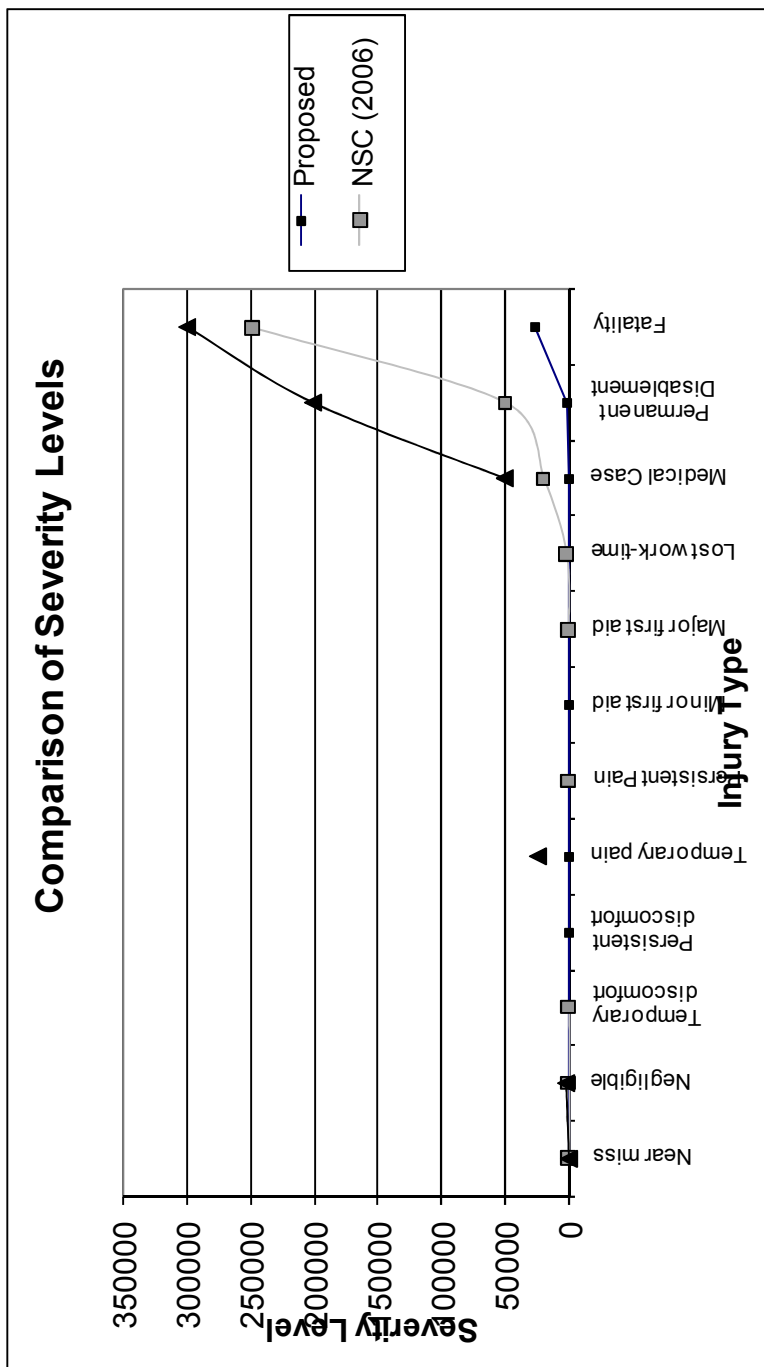

Figure 2.7 – Comparison of injury severity levels

A version of the probability and severity scales will be used during the Delphi process for quantifying construction safety risks. These scales are provided to the expert panelists who are asked to rate both the average probability (on the 1-10 scale) and average severity of each risk for each activity. The specific process used for the Delphi method and the results are presented in the following section of this manuscript.

Table 2.7 – Adjusted severity scales

Severity	Description	Original Delphi Score	Adjusted Risk Score
Near miss	Incident that does not result in harm to a worker	0	0
Negligible	Incident that resulted in extremely minor (mostly unnoticeable) injury	0	1
Temporary discomfort	Incident that resulted in temporary discomfort (one workday or less) but does not prevent the worker from functioning normally	1	2
Persistent discomfort	Incident that resulted in persistent discomfort (more than 1 workday) but does not prevent the worker from functioning normally	2	4
Temporary pain	Incident that resulted in temporary pain (one workday or less) but does not prevent the worker from functioning normally	3	8
Persistent Pain	Incident that resulted in persistent pain (more than 1 workday) but does not prevent the worker from functioning normally	4	16
Minor first aid	Incident that required minor first aid treatment. The worker may not finish the workday after the incident but returned to work within 1 day.	5	32
Major first aid	Incident that required major medical treatment (worker returned to regular work within 1 day)	6	64
Lost work-time	Incident that resulted in lost work time (worker could not return to regular work within 1 day)	7	128
Medical Case	Incident that resulted in significant medical treatment and resulted in lost work time (worker could not return to regular work within 1 day)	8	256
Permanent Disablement	Incident that results in an injury that causes permanent disablement	9	1024
Fatality	Incident that results in the death of a worker	10	26,214

2.5. RESULTS

This section of the report will be divided into two main sub sections: the results of the formwork field observations and industry survey and the results of the risk quantification effort using the Delphi process. The results of the formwork activity classifications will

be presented first because the list and descriptions resulting from this phase of the research was incorporated into the subsequent Delphi study.

2.5.1. Formwork Activities

2.5.1.1. *Field Observation Results*

The first research effort, though minor, was to determine the specific activities required to construct concrete formwork. The lack of literature on the topic warranted specific research efforts on the topic. As previously indicated, two methods were implemented: field observations and surveys of seasoned industry professionals. The major purpose of the field observations was to create a survey to send to industry professionals. Observations were conducted until significant repetition (no new observations observed in a four-hour period) occurred.

In total, time and motion data was collected for four eight-hour workdays totaling 256 worker-hours of observation. Additionally, the specific activities of twenty-two different individuals were observed. The following is a summary of the three projects that were observed.

Project 1: Construction of concrete formwork for elevated slabs in Portland, OR

- Eight individuals were observed for a total of eight hours (total of 64 worker-hours)
- Eight individuals were interviewed for 15 minutes each

Project 2: Construction of concrete formwork for footings in McMinnville, OR

- Four individuals were observed for a total of eight hours (total of 32 worker-hours)

Project 3: Construction of concrete formwork for first-story walls and elevated slabs in Everett, WA.

- Two separate crews, each consisting of 5 workers, observed for a total of 16 hours (total of 160 worker-hours)

After the third project was reviewed, sufficient repetition was observed. In other words, no new activities were observed in the last four hours of worker observations. The last four hours of worker observation occurred on Project 3, representing a total of 40 worker-hours without observing a new activity. The observations resulted in the following activities. The descriptions for these activities can be found in the survey sent to industry professionals in Appendix B.

1. Transport materials and equipment without motorized assistance
2. Transport materials using construction vehicle or other motorized assistance
3. Lift or lower materials, form components or equipment
4. Hold materials or components in place (static lift)
5. Accept/load/connect materials or forms from crane
6. Cut materials using skill or table saw
7. Nail/screw/drill form components or other materials
8. Hammer using sledgehammer or other equipment
9. Plumb and/or level forms using body weight, pry bar or other equipment
10. Ascend or descend ladder
11. Work below grade or in confined space
12. Work above grade (>5 ft) or near uncontrolled opening
13. Inspect forms and construction planning
14. Excavation

All of the activities observed may be classified in one, and only one of the above activities. Therefore, the list above and the corresponding definitions provided in the survey in Appendix B represent the relevant results.

2.5.1.2. *Industry Survey Results*

2.5.1.2.1. *Respondent Demographics*

In order to verify the list created, the author's contacted a group of experts in the area of formwork construction. The individuals were identified because of their vast industry experience and connection to the author. In this respect the participants may be considered a convenience sample. The formwork activities survey was sent to a total of ten individuals, eight of which responded resulting in a response rate of 80 percent. The eight respondents represented five different major construction firms and most of the respondents work in the Pacific Northwest. The average number of years of experience managing concrete formwork construction of the respondents was 19.25 years. A summary of the respondent demographics is provided in Table 2.8.

Table 2.8 – Industry survey demographics

Respondent	Contractor ID	Years of Experience Managing Concrete Formwork Construction	Geographic Region
1	A	10	WA
2	A	30+	OR
3	B	20	OR/WA
4	C	22	OR
5	D	35	OR/AK
6	E	8	WA
7	E	4	LA
8	E	25	WA

Each respondent was asked to review the concrete formwork activities form (Appendix B). The respondents were asked to review each activity and description and to add, remove, or alter the list and descriptions. While these individuals have experience mainly

in the Northwest, the author believes that the individuals have sufficiently broad experience to provide an adequate review.

The reviewers made several clarifying comments and suggested the addition of two activities that had not been included: the installation of form liners and the application of form oil. The comments and suggestions made by the reviewers were considered by the author and a final list of activities with descriptions was created. These activity classifications, with descriptions, are used later as an integral component of the Delphi survey. The final list is provided in the following section.

2.5.1.2.2. Findings

Field observations and the formwork activities survey resulted in the following list. The identifying numbers are also included in this list as the numbers are used for randomization during the Delphi process.

Transport materials and equipment without motorized assistance

Transporting equipment and materials may include carrying items of varying weights such as 2x4's, plywood, form panels, ties, cat heads, adjustable pipe braces, etc. from one location to another. Workers may use a wheelbarrow or bucket with handles or may carry materials by hand. This activity is often performed at height, below grade, or on rough or uneven surfaces.

Transport materials using construction vehicle or other motorized assistance

Materials may be transported by vehicles such as trucks, skid steers, forklifts, cranes or scissor lifts when the equipment is readily available or when the site is relatively large and formwork sites, mills and material/equipment storage is spread. Motorized transport is typically used when it is time-prohibitive or otherwise unrealistic for workers to transport materials by hand. This activity primarily involves operating transportation

equipment through the construction site. This activity may be performed at height, below grade or on rough or uneven surfaces.

Lift or lower materials, form components or equipment

Perhaps one of the most common activities for any construction process, lifting and lowering involves unassisted vertical transport of construction materials, formwork components or equipment. The process of forming concrete may require that workers lift materials from foot-level to a higher grade or from foot-level to a lower grade. In many cases workers will pass materials, equipment, or components to co-workers located at higher or lower grades without the assistance of pulleys, cranes or other mechanical devices. This activity is often performed at height, below grade, or on rough or uneven surfaces.

Hold materials or components in place (static lift)

The process of forming concrete may require workers to temporarily support a portion of the concrete form while other workers connect materials or components. This activity involves a static lift and may be accompanied by lifting/lowering. This activity may occur when work teams connect panels to stakes/columns, install bracing, level or plumb forms, etc. Typically, the worker holding the materials or components must wait for other workers to complete tasks before relief. This activity is often performed at height, below grade, or on rough or uneven surfaces.

Accept/load/connect materials or forms from crane

When a crane is used to transport materials or form components workers must accept the materials from the crane and/or load the crane with excess materials or waste. Workers must direct the crane operator as the material is lifted/lowered and may be required to physically accept the load. This activity is most likely to occur when formwork operations occur above or below grade and the use of scissor lifts or worker transport is

unrealistic. A combination of aerial lifts and cranes may be used in this activity. This activity is often performed at height, below grade, or on rough or uneven surfaces.

Cut materials using circular or table saw

During most formwork operations, materials such as 2x4's, plywood or aluminum must be cut to size. Typically, equipment such as a circulating saw, reciprocating saw or table saw is used to cut materials. Other equipment may be used in some cases. This activity requires the worker to operate such equipment and guide materials during cutting/ripping. This activity is often performed at height, below grade, or on rough or uneven surfaces.

Nail/screw/drill form components or other materials

Nailing or screwing form components or materials may involve the use of a hammer (typically larger than 20 oz.), nail gun, electric screwdriver, impact wrench, staple gun or other basic equipment. The worker may be required to repeat this activity for an extended period of time at certain stages of the formwork process. When gang forms are used, special forming hardware may be used. This activity is often performed at height, below grade, or on rough or uneven surfaces.

Hammer using sledgehammer or other equipment

This activity involves hammering stakes or other components into the soil or other material. This activity is different from nailing components and materials because heavier tools such as a sledgehammer are used to drive objects. In other words, hammering in this category refers to an activity that requires fewer strikes of larger force than nailing. This activity is often performed at height, below grade, or on rough or uneven surfaces.

Plumb and/or level forms using body weight, pry bar or other equipment

Leveling and plumbing forms is a common activity for nearly all formwork operations and involves using body weight, pry bars, or other equipment to shift and adjust the formwork. This activity may be executed by a single individual or multiple individuals. A

screw jack may be used for this activity and some workers may be surveying or using hand levels, lasers, or plumb bobs to ensure proper placement. This activity is often performed at height, below grade, or on rough or uneven surfaces.

Ascend or descend ladder

Operations that occur above or below grade typically require workers to ascend or descend ladders in order to reach the work site. Ladders may be wooden, metal, or fiberglass and may vary in length substantially from one site to the next. Workers may be carrying materials or equipment as they ascend or descend ladders. In many cases, workers may simply climb up the formwork supports. This activity is often performed at height, below grade or on rough or uneven surfaces.

Inspect forms and construction planning

During construction workers and crew leaders often take time to inspect their work and plan for subsequent operations. Formwork must be inspected by a competent person prior to placing concrete. This activity is often performed at height, below grade, or on rough or uneven surfaces.

Excavation

In some situations the concrete forming process may require excavation. Excavation involves the use of appropriate equipment such as a backhoe, bulldozer, shovels, etc.

Form lubrication and preparation

Spraying form oil; spraying curing compound; setting and wetting curing blankets and setting expansion materials.

The activities listed and described above are important components of the safety equilibrium model as the risk demand depends largely on the activities performed by the workers. These worker activities were used in the Delphi process. The results of the

safety risk quantification (i.e., the quantification of the risk demand) are presented and discussed in the following section.

2.5.2. Risk Quantification of Formwork Activities (Delphi Results)

The results of the Delphi risk quantification are presented in this section. Because the Delphi process for this study involved the use of three rounds of data collection and an introductory survey, this section will be divided into four main sections: introductory survey results, Round 1 results, Round 2 results, and Round 3 results. The salient aspects of these two rounds will be summarized in this section. The results of Round 3 will be presented and discussed in detail, as they represent the final results of the process. The Round 3 results will also be analyzed and validated in subsequent sections.

2.5.2.1. *Introductory Survey Results*

Potential experts were identified in several ways. Individuals that currently participate on construction safety or risk management-related committees such as the American Society of Civil Engineers' Construction Site Safety Committee, have published books or journal articles on the topic of construction safety or risk management, or have participated in Delphi studies on the topic in the past were contacted and asked to participate. In total, 63 potential experts were identified.

In e-mail, potential experts were given the details of the study including a brief description of the potential commitment and purpose of the study. Potential experts were also asked to complete a brief introductory survey. The primary purpose of the introductory survey was to confirm individuals as experts according to the guidelines in literature (summarized in section 2.4.2.4.1).

Of the 63 individuals contacted, 31 individuals agreed to participate resulting in a participation rate of 49 percent. Of the 31 individuals that agreed to participate, 29 were certified as experts in the field of construction safety and risk management. In order to be

certified as an expert, each individual was required to meet at least four requirements listed in section 2.4.2.4.1.

This research involves the development of two distinct Delphi panels, each with certified experts. Therefore, the pool of 29 certified experts were randomly assigned to one of two panels. Using a random number generator in Microsoft Excel®, each certified expert was assigned a random number between 0 and 1. These numbers were then ranked from one to 29, where 1 represented the highest of the randomly-generated numbers and 29 represented the lowest. The first fourteen experts were assigned to participate in the risk demand quantification panel (the results of which are summarized in this manuscript). The remaining 15 experts (ranked from 15 to 29) were asked to participate in the quantification of the risk mitigation capacity of common safety program elements. The results of this second panel are presented in Manuscript 3. The demographics of the Delphi panel that was responsible for the quantification of formwork construction safety risk are presented in Table 2.9. Panelist names have been removed to maintain anonymity and have been replaced with a participant ID number. One should note that only the demographic information for the panelists that completed all phases of the study have been included.

As one can see from Table 2.9, the participants represent ten different states and every major geographical region of the United States. While two participants were from China, their experience and familiarity with the US construction industry was confirmed. All of the panelists that participated in the Demand Delphi panel have a degree from an accredited program in an institution of higher learning and 12 of 13 (92%) of the panelists have a graduate degree in a civil engineering, construction engineering and management (CEM), occupational safety and health, or risk management degree.

Table 2.9 – Delphi demand panel expert characteristics

ID	State	Country	Terminal Degree	Academic Position	Peer-reviewed Journals	Book or Book chapters	Years Industry Exp.	Licensure
D1	CO	USA	PhD	Professor	0	0	9	AIA
D2	CA	USA	MS	None	0	2	3	PE
D3	PA	USA	MS	None	20	2	18	PE
D4	NC	USA	MS	None	1	0	25	PE
D5	OR	USA	MS	None	0	0	19	None
D6	--	China	PhD	Professor	49	12	4	None
D7	OR	USA	BS	None	0	1	13	Other
D8	DC	USA	MS	None	10	5	26	CIH
D9	FL	USA	PhD	Professor	45	3	3.5	PE
D10	WI	USA	PhD	Professor	25	0	4	PE
D11	NC	USA	PhD	Ass't Professor	6	0	10	CSP
D12	VA	USA	MS	None	0	0	50	PE
D13	--	China	PhD	Professor	30	4	0	None

The most important aspect of Table 2.9 is the cumulative experience of the panel because the results of this study represent the consensus of these individuals. The collective qualifications of this Delphi panel are as follows:

- A large range of geographical regions are represented
- Six individuals possess a Ph.D., six possess a M.S., and one possesses a B.S. as their terminal degree in a related field of study
- Five individuals are employed at the full professor rank and one is employed as at the assistant professor rank at an accredited academic institution
- The panel has produced a total of 186 publications in peer-reviewed journals on the topic of construction safety and health or risk management
- The panel has produced 29 books on the topic of construction safety and health or risk management
- The panel has over 184 years of field experience in the construction industry
- The panelists have obtained six P.E. licenses, one C.S.P. license, and one A.I.A. license

Once certified as experts according to literature, the Delphi process continued with the transmission of the first round of surveys. An overview of the specific survey process is included in the following sections.

2.5.2.2. Delphi Round 1 Results

The certified experts were asked to complete an undefined number of surveys with the goal of achieving consensus. Since the objective of the surveys was to determine the safety risk demand associate with the construction of concrete formwork, the panel was asked to rate the probability and severity of each of the incident codes, for each activity. The ten incident codes used for this study are defined in section 2.3.2.1 and the thirteen worker-activities required to construct concrete formwork are numbered and described in section 2.5.1. In total, experts were asked to rate (2 components x 10 incident types x 13 activities = 260 ratings per round). An example of the survey forms used for round 1 is provided in Appendix C.

Some salient aspects of the Round 1 Demand survey are as follows:

- The order of activities presented on the form was organized randomly for each panelist's custom form using the random number generator in MS Excel ®. For each panelist the activities were assigned a random number. The random numbers were ranked from highest to lowest and the order of the ranks determined the order to the activities on the survey form.
- The order of the 10 potential safety risks was randomized for each panelist using a random number generator in MS Excel ®. For each panelist, the safety risks were assigned a random number. The random numbers were ranked from highest to lowest. The order of the ranks determined the order of the safety risks on the survey form.
- Panelists were provided with the incident classification descriptions and the formwork construction activity descriptions

- Panelists were asked to provide ratings for the average probability and average severity for the industry in general using their expert judgment
- Panelists were asked to provide probability and severity ratings considering a scenario where no safety program elements are implemented
- Panelists were provided with probability and severity scales introduced in section 2.4.2.5.

An example form, sent to an expert panelist is provided in Appendix C. This form is representative of all of the other survey forms except the order of the activities and the order of the safety risks is unique for each panelist.

All 15 of the panelists completed the first round survey. The median values for each probability score and each severity score represent the result of the round. As previously indicated, median values were used to minimize the effects of potentially biased individuals. The variation in the responses is represented by the absolute deviation calculated using the following equation (Eq. 2.2):

$$\text{Average Deviation from Median} = \text{Average} (\text{Median}_j - V_{ij}) \quad (\text{Eq. 2.2})$$

The absolute deviation was used to quantify variation rather than using standard deviation because standard deviation only applies to means. The author believe that tracking the absolute deviation is an appropriate metric given the nature of the study and the importance of reducing judgment-based bias despite the fact that it is not a traditional method of describing variation in data. A summary of the results (medians values only) can be found in Table 2.10 and 2.11.

Table 2.10 – Probability ratings obtained through the Delphi process

	PROBABILITY (1-10 SCALE)									
	Incident Type									
	Struck-by	Struck-against	Caught-in	Fall to Lower	Fall to Same	Over-exertion	Repetitive Motion	Exposure to Harmful Substances	Transportation Accidents	Other
A/D Ladder	4	3	3	7	4	4	3	2	1	1
Static Lift	5	6	5	4	5	6	3	2	2	2
Nail/Screw/Drill form components or other materials	6	5	4	4	5	5	6	2	1	2
Transport materials using construction vehicles or other motorized assistance	5	5	5	4	4	3	2	2	7	1
Accept/load/connect materials or forms from crane	7	6	6	4	5	4	3	2	4	2
Cut materials using circular or table saw	6	5	5	2	4	4	4	3	1	1
Inspect forms and construction planning	4	4	3	5	5	3	2	2	2	1
Lift or lower materials, form components or equipment	7	5	5	4	6	7	6	2	2	2
Transport materials and equipment without motorized assistance	4	4	4	4	6	6	5	2	4	1
Hammer using sledgehammer or other equipment	7	5	3	2	5	6	5	2	1	1
Plumb and/or level forms using body weight, pry bar or other equipment	6	6	5	5	6	7	5	2	1	1
Excavation	6	5	6	5	6	5	3	3	3	1
Form Lubrication and preparation	2	2	2	5	3	5	5	8	6	1

Table 2.11 – Severity ratings obtained through the Delphi process

	SEVERITY (1-10 SCALE)									
	Incident Type									
	Struck-by	Struck-against	Caught-in	Fall to Lower	Fall to Same	Over-exertion	Repetitive Motion	Exposure to Harmful Substances	Transportation Accidents	Other
A/D Ladder	6	6	5	9	6	3	3	2	3	1
Static Lift	7	6	6	7	5	6	4	3	5	2
Nail/Screw/Drill form components or other materials	7	6	6	7	6	5	5	4	1	2
Transport materials using construction vehicles or other motorized assistance	8	7	7	7	6	5	4	2	8	2
Accept/load/connect materials or forms from crane	8	7	7	7	6	4	3	2	5	2
Cut materials using circular or table saw	8	7	6	5	4	5	5	3	2	2
Inspect forms and construction planning	7	6	6	8	6	3	3	3	5	2
Lift or lower materials, form components or equipment	6	5	6	7	6	5	5	3	6	3
Transport materials and equipment without motorized assistance	6	6	6	7	6	7	5	3	5	2
Hammer using sledgehammer or other equipment	7	6	5	6	6	6	5	3	2	2
Plumb and/or level forms using body weight, pry bar or other equipment	7	6	7	8	5	5	5	3	1	1
Excavation	8	8	8	7	6	5	5	4	6	2
Form Lubrication and preparation	5	5	5	8	6	6	6	9	8	2

The values in Tables 2.10 and 2.11 correspond to the scales provided to the panelists (introduced and described in section 2.4.2.5). The analysis section of this manuscript presents the data and analyses in useable units of probability, severity, and risk.

One of the goals of this study is to achieve consensus among the expert panelists. The average of all of these deviations (i.e., the average of all of the average deviations) is 1.57 units for probability ratings and 1.86 for severity ratings. In other words, the absolute deviation for all of the probability ratings is 1.57 units and the absolute deviation for all of the severity ratings was 1.86 units. Since group consensus of the experts is vital to the quality and precision of the results, rounds 2 and 3 will focus on reducing the variation in the expert responses and obtaining the true probability and severity values.

2.5.2.3. *Delphi Round 2 Results*

The process implemented to conduct the second round of the Delphi process was very similar to Round 1. In order to further reduce judgment-based biases that may occur due to the order of risks and activities on the forms (e.g., primacy, contrast), the order of the activities was randomized once again. Also, the order of the risks was re-randomized. Both randomizations were achieved by using the Microsoft Excel ® random number generator using the same method as in Round 1. Respondents were also given the same background information as in round 1 (e.g., probability scale, severity scale, activity descriptions, and safety risk descriptions). However, the directions were slightly different from the first round and the panelists were given anonymous feedback. An augmented version of a Round 2 survey is provided in Appendix D for reference.

Round 2 differed from Round 1 in the following ways:

- Respondents were provided with their rating from the first round and the median rating from round 1 (the symbol || on the form represents the median response from the previous round)

- Respondents were specifically requested to consider the group median and re-consider their first round ratings given the collective group statistic.
- Respondents were asked to provide reasons for outlying responses if their chosen Round 2 response is two or more units from the Round 1 median response.

Surprisingly, the medians that resulted from Round 2 were identical to those from Round 1 (for Round 1 responses, please see Tables 2.10 and 2.11) despite the fact that many of the expert panelists chose to change their Round 1 responses. Experts tended to choose ratings that were closer to the Round 1 median response. This is illustrated by the fact that, for Round 2, the absolute deviation for all probability ratings was 0.59 units and the absolute deviation for the severity ratings was 0.71. One should note that the variance was nearly three times higher in the first round indicating that the experts have come much closer to consensus.

Between Round 1 and Round 2, two of the fifteen panelists failed to respond to the survey resulting in a total pool of 13 experts who completed Round 2. The default of two members was not considered detrimental for two reasons: (1) Literature suggests that 8 to 15 panel members is an ideal panel size and (2) the input of the two members who defaulted was still incorporated into the study.

In an effort to achieve even greater consensus, the author believed that extending the Delphi study to a third round and providing the expert panelists with reasons for outlying responses was important for achieving the highest quality results. This decision was also made based on the compelling comments made by the panelists on specific issues. On these Round 3 forms the reasons for outlying responses (i.e., ratings two or more units from the median) and the value for the outlying responses are provided in the end notes to the ratings table for each activity. The reader is encouraged to review these comments as they provide insight to the expert's opinions and explains some of the variation.

2.5.2.4. *Delphi Round 3 Results*

As indicated in the previous section, the author determined that a third round of Delphi surveys would strengthen the study as the expert panelists could review the anonymous reasons for outlying responses. The process implemented for Round 3 was the same as Rounds 1 and 2 as the order of the activities and the order of the safety risks were re-randomized to ensure minimum bias. Also, like Round 2, the panelists were provided with the median response from the previous round which, coincidentally, was the same as Round 1. In Round 3, the panelists were also provided with the reasons for outlying responses from Round 2. One should note that all feedback (median responses and reasons) is anonymous. In other words, no comments or ratings were ever accompanied by information that would identify the panelists to one another. This anonymity was ensured to eliminate the possibility of bias due to dominance. An augmented version of a Round 3 survey is provided in Appendix E.

The results of Round 3 were fairly similar to those in Round 2. While many of the ratings changed, especially those for the categories where panelists provided compelling reasons for their outlying responses, none of the median values changed. Therefore, the median values presented in Table 2.10 and 2.11 represent a summary of the final results of the safety risk demand quantification panel. These values, when interpreted with the scales, represent the safety risk demand components for the construction of concrete formwork.

While the median values did not change, the expert panel came closer to achieving consensus. The absolute deviation for all of the probability ratings is 0.38 units and the absolute deviation for all of the severity values is 0.49. These values indicate that the average deviation of all responses is within ± 0.5 unit. The author believe that this level of consensus is sufficient for this study due to the complex nature of the research question, the confounding factors that lead to safety risk ratings, and the variability in experiences among safety experts. Recalling the target consensus value from section 2.4.2.4.6, the results from the Delphi process was nearly half of the target variance of an

absolute deviation of 1 unit. Additionally, all 13 members from Round 2 completed a Round 3 survey. The following section will discuss the achievement of sufficient consensus in the Delphi process.

2.5.2.5. Consensus

To measure the consensus for each rating the absolute deviation was tracked. Additionally, the average of all of these values was used to represent the degree of consensus of the entire survey round. As previously indicated, the goal for consensus for this study was to have an average deviation (for the entire round) of 1 unit or less. The average deviation for all ratings, including both probability and severity, was 0.435 units.

2.6. ANALYSIS

This section of the manuscript will present an interpretation of the data and an analysis of the results presented in the previous section. The raw results of the data (i.e., median probability and median severity values) will be interpreted using the appropriate scales and will be graphically analyzed. The objective of this section is to determine the highest risk activities associated with the construction of concrete formwork, identify the risks that are highest for specific activities, and to indicate specifically how high the risks are in terms of actual risk values. The application section will discuss how the data obtained in this manuscript can be used to improve safety management.

2.6.1. Conversion to Appropriate Probability Units

One of the major objectives of this dissertation is to quantify the risks associated with the construction of concrete formwork. In the previous section, the results of the Delphi process have been summarized. Before this data can be used to calculate risk, the probability results must be converted to useable units (i.e., incidents per worker-hour). The raw probability values determined through the Delphi process were in units of worker-hours per incident and included a range of values for each rating (i.e., each rating

on the 1 to 10 scale represents a range of potential durations such as 1 to 10 worker-hours, 10 to 100 worker-hours, etc.). In order to analyze and apply these results, the probability values must be converted from a range of values to single point estimates with appropriate units.

The raw data from Table 2.10 was converted to single point estimates with units of incidents per worker-hour by following the following four steps:

1. Convert the scaled 1 to 10 values to actual terms of probability using the probability scale provided to the Delphi panel.
2. Find the mid-point of each range (e.g., 0.1 to 1 worker-hours per incident becomes 0.55 worker hours per incident)
3. Convert probability values from worker-hours per incident to incident per worker-hour by finding the inverse of the values determined in step 2 (e.g., 0.55 worker-hours per incident becomes 1.8 incidents per worker-hour).
4. Interpret resulting frequency values as probabilities (note: 0.018 incidents per worker-hour can also be described as a 1.8 percent chance that one worker will be injured in a one hour work period)

The steps required to convert the probability values are illustrated in Table 2.12. One should note that the values were converted because the original 1 to 10 values do not accurately represent the probability values in the scales. Furthermore, using worker-hours per incidents would be inappropriate and confusing because the higher the value (i.e., the higher the number of worker-hours per incident), the lower the probability.

Table 2.12 – Probability conversions

Scale value	Original Range provided to Delphi (worker-hours)	Worker-hours per incident	Probability
10	0.1 to 1	0.55	1.8E+00
9	1 to 10	5.50	1.8E-01
8	10 to 100	55.00	1.8E-02
7	100 to 1,000	550.00	1.8E-03
6	1,000 to 10,000	5,500.00	1.8E-04
5	10,000 to 100,000	55,000.00	1.8E-05
4	100,000 to 1,000,000	550,000.00	1.8E-06
3	1,000,000 to 10,000,000	5,500,000.00	1.8E-07
2	10,000,000 to 100,000,000	55,000,000.00	1.8E-08
1	Negligible	Negligible	0.0E+00

Each of the probability ratings from Table 2.12 were converted to useable probability values using the four steps above. The resulting probability values can be found in Table 2.13. One should note that these probabilities define the chance element for risk and are described for one worker conducting work for one hour. These probabilities would change given a different number of workers or work period.

2.6.2. Conversion to Appropriate Severity Values

The raw values from Table 2.10 were converted to the appropriate scaled values by replacing the raw 1-10 ratings obtained through the Delphi process with the scaled values from Table 2.7. For example, if the Delphi panel rated an average severity with a “2” the value of 2 was replaced with the scaled value of 4. The adjusted values can be found in Table 2.14.

Table 2.13 – Probability ratings (incidents per worker-hour)

	PROBABILITY									
	Incident Type									
	Struck-by	Struck-against	Caught-in	Fall to Lower	Fall to Same	Over-exertion	Repetitive Motion	Exposure to Harmful Substances	Transportation Accidents	Other
A/D Ladder	1.8E-06	1.8E-07	1.8E-07	1.8E-03	1.8E-06	1.8E-06	1.8E-07	1.8E-08	0.0E+00	0.0E+00
Static Lift	1.8E-05	1.8E-04	1.8E-05	1.8E-06	1.8E-05	1.8E-04	1.8E-07	1.8E-08	1.8E-08	1.8E-08
Nail/Screw/Drill form components or other materials	1.8E-04	1.8E-05	1.8E-06	1.8E-06	1.8E-05	1.8E-05	1.8E-04	1.8E-08	0.0E+00	1.8E-08
Transport materials using construction vehicles or other motorized assistance	1.8E-05	1.8E-05	1.8E-05	1.8E-06	1.8E-06	1.8E-07	1.8E-08	1.8E-08	1.8E-03	0.0E+00
Accept/load/connect materials or forms from crane	1.8E-03	1.8E-04	1.8E-04	1.8E-06	1.8E-05	1.8E-06	1.8E-07	1.8E-08	1.8E-06	1.8E-08
Cut materials using circular or table saw	1.8E-04	1.8E-05	1.8E-05	1.8E-08	1.8E-06	1.8E-06	1.8E-06	1.8E-07	0.0E+00	0.0E+00
Inspect forms and construction planning	1.8E-06	1.8E-06	1.8E-07	1.8E-05	1.8E-05	1.8E-07	1.8E-08	1.8E-08	1.8E-08	0.0E+00
Lift or lower materials, form components or equipment	1.8E-03	1.8E-05	1.8E-05	1.8E-06	1.8E-04	1.8E-03	1.8E-04	1.8E-08	1.8E-08	1.8E-08
Transport materials and equipment without motorized assistance	1.8E-06	1.8E-06	1.8E-06	1.8E-06	1.8E-04	1.8E-04	1.8E-05	1.8E-08	1.8E-06	0.0E+00
Hammer using sledgehammer or other equipment	1.8E-03	1.8E-05	1.8E-07	1.8E-08	1.8E-05	1.8E-04	1.8E-05	1.8E-08	0.0E+00	0.0E+00
Plumb and/or level forms using body weight, pry bar or other equipment	1.8E-04	1.8E-04	1.8E-05	1.8E-05	1.8E-04	1.8E-03	1.8E-05	1.8E-08	0.0E+00	0.0E+00
Excavation	1.8E-04	1.8E-05	1.8E-04	1.8E-05	1.8E-04	1.8E-05	1.8E-07	1.8E-07	1.8E-07	0.0E+00
Form Lubrication and preparation	1.8E-08	1.8E-08	1.8E-08	1.8E-05	1.8E-07	1.8E-05	1.8E-05	1.8E-02	1.8E-04	0.0E+00

Table 2.14 – Adjusted Severity Values

Activity	SEVERITY (ADJUSTED)										
	Incident Type										
	Struck-by	Struck-against	Caught-in	Fall to Lower	Fall to Same	Overexertion	Repetitive Motion	Exposure to Harmful Substances	Transportation Accidents	Other	
A/D Ladder	64	64	32	1024	64	8	8	4	8	2	
Static Lift	128	64	64	128	32	64	16	8	32	4	
Nail/Screw/Drill form components or other materials	128	64	64	128	64	32	32	16	2	4	
Transport materials using construction vehicles or other motorized assistance	256	128	128	128	64	32	16	4	256	4	
Accept/load/connect materials or forms from crane	256	128	128	128	64	16	8	4	32	4	
Cut materials using circular or table saw	256	128	64	32	16	32	32	8	4	4	
Inspect forms and construction planning	128	64	64	256	64	8	8	8	32	4	
Lift or lower materials, form components or equipment	64	32	64	128	64	32	32	8	64	8	
Transport materials and equipment without motorized assistance	64	64	64	128	64	128	32	8	32	4	
Hammer using sledgehammer or other equipment	128	64	32	64	64	64	32	8	4	4	
Plumb and/or level forms using body weight, pry bar or other equipment	128	64	128	256	32	32	32	8	2	2	
Excavation	256	256	256	128	64	32	32	16	64	4	
Form Lubrication and preparation	32	32	32	256	64	64	64	1024	256	4	

2.6.3. Resulting Risk Values

One may recall that the units of severity collected during the Delphi process were in units of severity per incident (i.e., frequency). These frequency values represent the probability that the average incident will occur to one worker in a one-hour period. No conversion of the severity units is required. In order to quantify unit risk values, the probability ratings must be multiplied by the severity ratings.

For each safety risk associated with each activity, the converted values from Table 2.13 were multiplied by the severity values from Table 2.14. The resulting matrix is represented in the following Table 2.15.

Table 2.15 – Risk scores (severity per worker-hour)

	RISK: UNITS OF SEVERITY										
	Incident Type										
	Struck-by	Struck-against	Caught-in	Fall to Lower	Fall to Same	Overexertion	Repetitive Motion	Exposure to Harmful Substances	Transportation Accidents	Other	
A/D Ladder	1.2E-04	1.2E-05	5.8E-06	1.9E+00	1.2E-04	1.5E-05	1.5E-06	7.3E-08	0.0E+00	0.0E+00	
Static Lift	2.3E-03	1.2E-02	1.2E-03	2.3E-04	5.8E-04	1.2E-02	2.9E-06	1.5E-07	5.8E-07	7.3E-08	
Nail/Screw/Drill form components or other materials	2.3E-02	1.2E-03	1.2E-04	2.3E-04	1.2E-03	5.8E-04	5.8E-03	2.9E-07	0.0E+00	7.3E-08	
Transport materials using construction vehicles or other motorized assistance	4.7E-03	2.3E-03	2.3E-03	2.3E-04	1.2E-04	5.8E-06	2.9E-07	7.3E-08	4.7E-01	0.0E+00	
Accept/load/connect materials or forms from crane	4.7E-01	2.3E-02	2.3E-02	2.3E-04	1.2E-03	2.9E-05	1.5E-06	7.3E-08	5.8E-05	7.3E-08	
Cut materials using circular or table saw	4.7E-02	2.3E-03	1.2E-03	5.8E-07	2.9E-05	5.8E-05	5.8E-05	1.5E-06	0.0E+00	0.0E+00	
Inspect forms and construction planning	2.3E-04	1.2E-04	1.2E-05	4.7E-03	1.2E-03	1.5E-06	1.5E-07	1.5E-07	5.8E-07	0.0E+00	
Lift or lower materials, form components or equipment	1.2E-01	5.8E-04	1.2E-03	2.3E-04	1.2E-02	5.8E-02	5.8E-03	1.5E-07	1.2E-06	1.5E-07	
Transport materials and equipment without motorized assistance	1.2E-04	1.2E-04	1.2E-04	2.3E-04	1.2E-02	2.3E-02	5.8E-04	1.5E-07	5.8E-05	0.0E+00	
Hammer using sledgehammer or other equipment	2.3E-01	1.2E-03	5.8E-06	1.2E-06	1.2E-03	1.2E-02	5.8E-04	1.5E-07	0.0E+00	0.0E+00	
Plumb and/or level forms using body weight, pry bar or other equipment	2.3E-02	1.2E-02	2.3E-03	4.7E-03	5.8E-03	5.8E-02	5.8E-04	1.5E-07	0.0E+00	0.0E+00	
Excavation	4.7E-02	4.7E-03	4.7E-02	2.3E-03	1.2E-02	5.8E-04	5.8E-06	2.9E-06	1.2E-05	0.0E+00	
Form Lubrication and preparation	5.8E-07	5.8E-07	5.8E-07	4.7E-03	1.2E-05	1.2E-03	1.2E-03	1.9E+01	4.7E-02	0.0E+00	

The results summarized in Table 2.15 represent the ultimate objective of this manuscript as each safety risk value has been adequately quantified through a rigorous Delphi study. While the resulting data is compelling in its own right, the data is briefly analyzed to determine the risk values for each safety classification code and for each specific formwork activity.

2.6.4. Safety Risk Analysis of Formwork Construction Activities

The data matrix in Table 2.15 can be used to describe several unique aspects of risk during the process of forming concrete. For example, the data can be used to determine the total safety risk for each of the risk classification codes for any combination of activities. The risk values in Table 2.16 represent the risk values for each safety risk classification code for the sum of all activities. The units of risk will be defined in terms of severity (S). One can see from this table that most risk values lie between 0.04 and 1 units of severity. The highest safety risk for the construction of concrete formwork is “exposure to harmful substances” with a quantified risk level of 18.6 units of severity. The lowest risk level belongs to the “Other” category which accounts for only 0.00000016 units of severity.

Table 2.16 – Comparison of risk values among safety risk classification codes

Safety Risk Classification Code	Risk Value (Severity)
Exposure to Harmful Substances	18.62
Fall to Lower	1.880
Struck-by	0.962
Transportation Accidents	0.512
Overexertion	0.165
Caught-in	0.078
Struck-against	0.059
Fall to Same	0.046
Repetitive Motion	0.015
Other	0.000

Further analysis of the data was conducted to determine the highest risk activities associated with the construction of formwork. The risk value for each safety risk code

was summed to determine the total safety risk score for each activity. The results of this analysis are presented in Table 2.17. Most safety risk values are between 0.02 and 1 units of severity. The highest risk was associated with form lubrication and preparation (18.7 units of severity) and the lowest risk activity is associated with inspection and planning (0.0062 units of severity).

Table 2.17 – Comparison of risk values among formwork construction activities

Formwork Construction Activity	Safety Risk Score (Severity)
Form lubrication	18.67172
A/D ladder	1.86208
Crane materials	0.51349
Motorized transport	0.47512
Hammer w/ sledgehammer, etc.	0.24728
Lift or lower materials, etc.	0.19398
Excavation	0.11231
Plumb and/or level forms	0.10647
Cut materials using circular or table saw	0.05018
Transport materials without motorized assistance	0.03613
Nail/Screw/Drill form components or other materials	0.03235
Static Lift	0.02758
Inspect forms and construction planning	0.00618

The brief analysis of the data indicates that form lubrication and preparation, lifting or lowering form components, interacting with a crane, and ascending and descending ladders are the highest risk activities. The lowest risk activities include inspection and planning, cutting materials, and transporting materials without motorized assistance. The total risk score for the construction of concrete formwork is 22.63 units of severity.

Limitations

One should note that all of the risk values obtained through the Delphi process are limited in the following ways due to the specific directions given to the Delphi panelists:

- The values represent the average for all firms in the industry regardless of size, geographic location, safety record, etc.

- The risk values represent average risk levels that would occur if no safety programs are implemented.
- The risk values represent the judgment of safety experts and do not represent empirical data

The data analyzed in this section can be used in a variety of methods for quantifying, modeling, and managing safety risk for formwork construction operations. The tables presented in this section can be used to identify the high-risk activities that occur on site and to guide safety managers in their safety management efforts. For example, the data suggests that risk reduction efforts may be necessary to reduce high-risk activities such as form lubrication and preparation. Similarly, the timing and focus of safety program element implementation can be designed using the data presented in this section. In addition to this data analysis, the following section presents a schedule-based risk tracking method that may be implemented to identify high-risk intervals.

2.7. APPLICATION

The data collected and analyzed in the previous two sections of this manuscript can be used to effectively quantify and track safety risk in several ways. One technique that the author believes may be especially effective is introduced and exemplified in this section. Yi and Langford (2006) suggest a schedule-based method for risk quantification. This method involves tracking specific processes and using risk estimations to determine periods of exceptionally high risk. While Yi and Langford present an excellent framework, the paper does not provide risk estimations for the processes and does not illustrate or validate the model with empirical or subjective data. This section of the report will illustrate how the data collected, presented and analyzed in this manuscript can be used to predict exceptionally high risk periods based on the predicted worker activities for a given time period.

2.7.1. Risk Tracking Method

The author offer a hypothetical workday where a small work-crew is charged with the responsibility to construct concrete formwork. Table 2.15 provides a summary of the major worker activities throughout the day in one-hour time increments. For argument sake, assume that only one worker is participating in an activity at any given time but that workers may conduct different activities at the same time. Using this hypothetical schedule, the risk values for all of the activities implemented in a given one-hour period were summed. This value represents the risk value for the time period. The risk values for the entire eight-hour workday are plotted in Figure 2.7.

As one can clearly see from Figure 2.7, the risk level (i.e., the risk demand) on the worksite changes from hour-to-hour based on the activities performed by the workers. It appears as if there is a large spike in risk from 12 pm to 2 pm becoming nearly five times higher than the average risk for the first six hours of work. This information could be very useful for construction safety management. For example, this information enables a manager to make any of the following decisions that would theoretically improve safety on-site:

- Managers could shift activities to prevent the simultaneous performance of multiple high-risk work activities
- Safety managers could plan to implement safety program elements at opportune times before risk levels are expected to peak
- Safety managers could structure their workday in order to be present during times of high risk and, perhaps conduct office work in the job trailer, during periods when risk is expected to be low
- Safety managers could alert workers when risk levels are expected to be higher thus improving the ability of workers to identify and appropriately react to potential hazards

To illustrate an application of this method, the author have restructured the hypothetical workday in Table 2.18. By simply rearranging a few select activities, the period of extraordinary risk may be avoided. One must note that, in practice, activities may not simply be rearranged on a worksite at the discretion of the safety manager. In many cases, work activities must be performed in a certain order and at certain times to complete the work and ensure adequate productivity. In other words, any given activity may have a specific predecessor and may have to be completed before another activity begins. Additionally, activities, such as those that involve crane usage, must frequently be performed at specific times to ensure adequate productivity of the entire worksite. Nevertheless, it may be possible for some activities to float without having a significant impact on productivity, thereby allowing a safety manager to select work patterns that enhance worksite safety. With these issues in mind, the author presents a revised work schedule with four minor schedule changes. These changes are as follows:

1. Ascend/Descend Ladder moved from 11 am-1 pm to 7-9 am.
2. Nail/Screw/Drill form components moved from 10 am - 12 pm to 7 am -9 am
3. Lift/lower forms, materials, or equipment from 9 am to 12 pm to 12 pm to 3 pm.
4. Plumb/level forms moved one hour earlier
5. All other scheduled activities remain the same

The changes listed above can be seen visually in Table 2.19 and Figure 2.8 reflect the changes listed above. In Figure 2.8 the original work period is outlined and the revised work period for the altered work activity is hatched. One may note from an analysis of Figure 2.9, that includes a plot of the risk over time for the original schedule and revised (i.e., leveled) schedule on the same axis, that rearranging these activities prevents the peak risk that was apparent on the original plot. A close examination reveals that the original schedule has a peak risk values of 2.4, 3.3, 2.8, and 2.3 units of severity for the worker hour for one worker at 11-12pm, 12-1 pm, 1-2 pm, and 2-3 pm, respectively. The revised schedule, however, has peak values of 1.9, 2.1, 2.2, and 2.2 units of severity for

one worker for the given hour at 7-8 am, 8-9 am, 1-2 pm, and 2-3 pm respectively. The peak risks have been reduced by over 15 percent as a result of shifting activity start times. One should note that the number and duration of activities has not been changed, only the start times and end times have been adjusted. Furthermore the total risk (i.e., the area under each of the curves) has not changed. Despite the fact that the cumulative risk has not changed, periods of extraordinarily high risk may be avoided by simply rescheduling a few activities in the original schedule. While these results may not be typical in practice, the author believe that this approach to safety management, using the data presented in this manuscript, may be used to effectively minimize or plan for high-risk work periods.

One of the chief benefits of the application outlined above is the potential ability to reduce periods of extremely high risk by leveling the risk throughout the workday. The potential benefits of this technique may not be immediately visible to the reader as the total risk during the workday has not decreased (the area under the original risk curve is equal to that of the curve for the revised schedule). A publication by Mitropolis et al. (2006) presents a theoretical model that provides some insight.

Mitropolis et al. (2006) reviewed several safety risk theories and combines these theories with a systems approach to create a model that describes construction safety risk. As indicated in the publication, one of the keys to effective safety management is avoiding extreme peaks in cumulative risk at any given time. In other words, effective safety managers help to prevent incidents by avoiding working in periods of uncontrollable risk, known as the “danger zone.” The work of Yi and Langford (2006) supports this model and suggests that worksite safety can be enhanced through scheduling techniques that level risk. Therefore, the author believes that the techniques presented in this manuscript may be used to improve effectiveness of safety management.

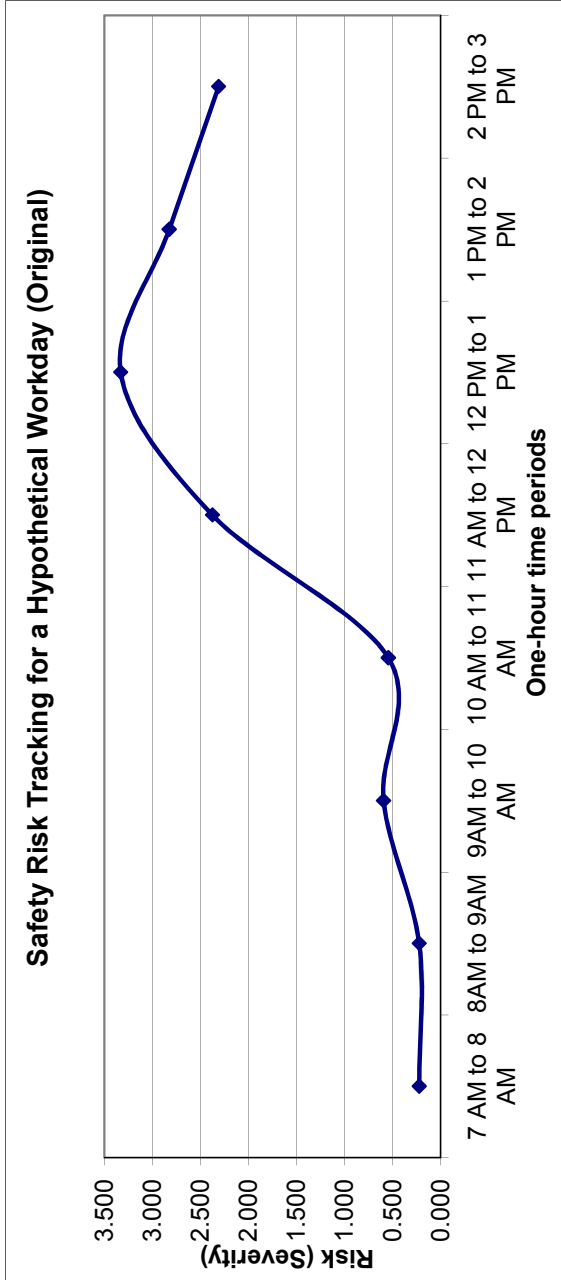

Figure 2.8 – Schedule-based safety risk plot (original)

Table 2.19 – Risk tracking for a hypothetical workday (leveled)

	Leveled									
	7 AM to 8 AM	8 AM to 9 AM	9 AM to 10 AM	10 AM to 11 AM	11 AM to 12 PM	12 PM to 1 PM	1 PM to 2 PM	2 PM to 3 PM		
A/D Ladder										
Static Lift										
Nail/Screw/Drill										
Motorized Transport										
Accept/Load crane materials										
Cut materials										
Inspect and plan										
Lift or lower materials										
Transport w/o motorized assistance										
Hammer										
Plumb and/or level forms										

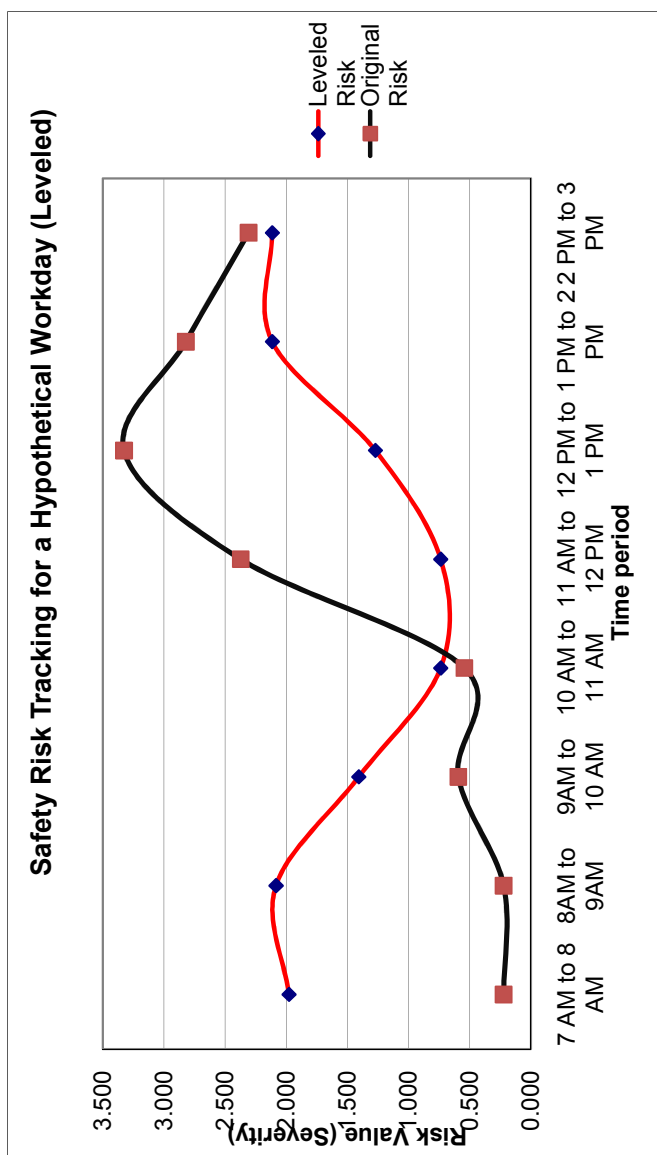

Figure 2.9 – Schedule-based safety risk plot (levelled)

The risk tracking process illustrated above involves the quantification of unit risk. That is, the risk units in Figure 2.8 are units of severity. Another method, which is a more detailed and more appropriate for use to measure and track expected risk involves the use of an expected schedule and expected exposure durations. An example of this method of risk tracking is illustrated in Manuscript 4. In this manuscript an actual project is used to illustrate a risk tracking method that incorporates exposures and is used, along with actual project data, to validate the results. The author refers the reader to Manuscript 4 for a very detailed description of this proposed tracking method and the validation of the results of this manuscript.

One should note that the application of the data presented in this manuscript is not limited to this discussion. In fact, there are several additional applications of the data that will not be discussed in detail here. For example, the data may be used, along with expected exposure values to track the cumulative risk (in units of severity) for individual workers to identify high-risk positions and the data can be used to compare crew exposure during a given workday to avoid inequality in risk exposure. The author encourages the reader to further analyze the data and apply it to improve other safety management techniques.

2.8. CONCLUSIONS

The primary purpose of this manuscript was to quantify the construction safety risks associated with the construction of concrete formwork. Formwork was selected as the highlighted construction process because literature and OSHA statistics that indicate that the process involves a high rate of sever construction accidents and because the process is involved in nearly every construction project. In order to determine the safety risk demand of the process of constructing formwork, the specific construction activities and the potential safety risks needed to be identified and described. Using a total of 256 worker-hours of field observation on 3 projects a preliminary primary list of worker-activities associated with formwork construction and corresponding descriptions was

created. This preliminary list was reviewed, augmented, and validated by a group of eight individuals with an average of approximately 20 years of experience resulting in a final list of thirteen distinct and well-defined activities. The potential construction safety risks were classified in ten different codes by aggregating the codes developed by three major data sources.

Once the activities and potential risks were defined, the Delphi process was implemented in an effort to quantify the probability and severity components associated with each activity for each safety risk. The Delphi process was specifically designed for this study using guidance from literature. Additionally, forms of judgment-based bias were identified from social psychology literature and techniques such as randomization, feedback, and anonymity were implemented during the Delphi process in order to minimize these biases.

During the Delphi process described for this phase of the research, an initial group of fifteen individuals were certified as experts according to criteria defined by literature. All fifteen experts completed the first round of surveys. Thirteen of fifteen experts completed Rounds 2 and 3. In the second round, the experts were provided with a re-randomized survey form that included the median response from Round 1. Experts were also asked to provide reasons for responses that were two or more units from the Round 1 median. In Round 3, all remaining experts completed the forms and were asked to reconsider their ratings in light of their peer's reasons for outlying responses. During the three rounds the expert panel closely approached consensus which was measured by the absolute deviation. After the third round, the absolute deviation was less than 0.5 units on a 1 to 10 scale. In total, the expert panel provided over 10,000 ratings during the three rounds.

The resulting data matrix from the Delphi survey was presented and converted to useable units of probability, severity, and risk. The subsequent analysis indicated that the highest risk activities included the application of form oil, lifting and lowering form

components, and accepting materials from a crane. Considering all formwork activities, the highest safety risks were exposure to harmful substances, struck-by, and overexertion. The data matrix was also applied to a hypothetical workday. The expected work activities were identified for each time period and the safety risk demand was calculated for each hour. The data was used to quantify the expected risk associated with the expected activities. The expected risk for each hour was then plotted over time. An analysis of the plot revealed a spike in the expected risk demand in a given and illustrated how the data could be applied to the construction industry to improve management techniques.

The following manuscript, Manuscript 3, will involve the quantification of the safety risk mitigation abilities (i.e., capacity) of various essential safety program elements. The safety risks identified and classified in this manuscript will be used and the essential safety program elements will be identified in literature. Once the program elements and safety risks have been identified and described, the same Delphi process will be implemented to determine the ability of each element to reduce the probability and/or severity of each safety risk. The data from the present manuscript and the data obtained in the process discussed in the third manuscript will be combined, analyzed, and validated in the final manuscript.

MANUSCRIPT 3.0
RISK MITIGATION CAPACITY OF ESSENTIAL CONSTRUCTION
SAFETY AND HEALTH PROGRAM ELEMENTS

Matthew R. Hallowell

3.1. PREFACE

In the present manuscript, the author identifies essential safety program elements and attempts to quantify the ability of these elements to reduce the probability and/or the severity of the ten safety risk types identified and described in Manuscript 2. In this manuscript the concept of Capacity as a component of the safety equilibrium model is revisited, the essential safety program elements are identified in literature, and the Delphi method is used to quantify the risk mitigation resulting from the implementation of each essential program element. The results presented in this manuscript are validated and further analyzed in Manuscript 4.

3.2. INTRODUCTION

The objective of this research phase is to quantify the risk mitigation resulting from the implementation of highly-effective safety program elements. The research presented in this manuscript can be used in a variety of ways. For example, identifying the risk mitigation associated with each safety program element allows a manager to strategically select safety program elements for implementation based on their relative effectiveness. Also, the risk mitigation data can be used in tandem with the risk demand data described in the previous manuscript to evaluate the effectiveness of the safety program elements when specific activities are expected.

In order to populate the capacity portion of the safety equilibrium model introduced in Manuscript 1, the following components must be identified: (1) construction safety risk classification codes, (2) essential safety program elements, and (3) the ability of the essential safety program elements to mitigate a portion of each of the safety risks.

Following the structure of Manuscript 2, the classification codes developed in section 2.3.2.1 are used for this Manuscript and the Delphi research method is implemented to quantify risk mitigation. The essential safety program elements are identified in literature, however.

Before proceeding, it is appropriate to revisit the concept of capacity introduced in Manuscript 1. Safety risk capacity is defined as the risk mitigation that results from the implementation of safety program elements. Capacity is calculated by multiplying the reduction in probability of an incident by the reduction in severity. Capacity may be defined for individual program elements or may be expressed by the sum of the mitigation (i.e., individual capacities) of all selected safety program elements.

According to Hallowell and Gambatese (2007), the method of quantifying capacity requires one to identify and analyze risk mitigation in a formal and methodical fashion. When quantifying the safety capacity one must perform the following five activities. These five activities are illustrated in Figure 3.1. In this figure, the Greek letters represent independent safety program elements.

1. *Identify common safety risks*
2. *Identify essential safety program elements*
3. *Identify and quantify the ability of safety program elements to mitigate a portion of the common safety risks*
4. *Sum the mitigation ability for each safety program element*

5. Calculate the total capacity of the safety system by summing the mitigation ability of the safety program elements planned for implementation

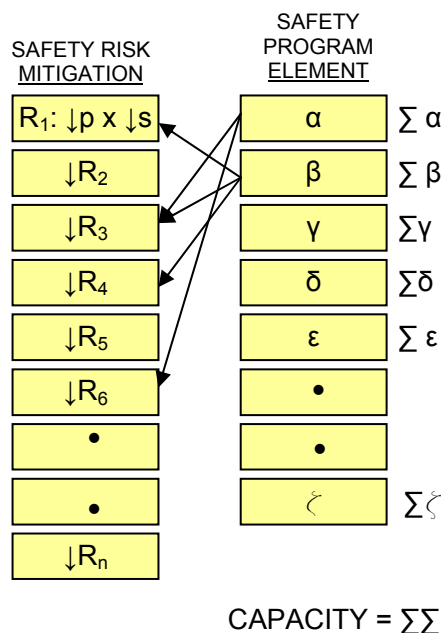

Figure 3.1 – Safety Risk Mitigation

As one may recall from Manuscript 1, the construction industry lacks a standard method for selecting safety program elements for a site safety program and the various methods implemented are informal. For example, some safety managers select elements based on literature, word of mouth, or basic intuition. The research effort described in this manuscript aims to quantify the risk mitigation associated with the implementation of safety program elements using the concepts of demand and capacity. The author believes that this information can be used for strategic and formal selection of elements, especially when a small subset of elements must be chosen due to limited resources.

3.3. LITERATURE REVIEW

Construction safety management techniques have improved significantly following the Occupational Safety and Health Act of 1970. This act, which placed the responsibility of construction safety on the employer, has resulted in a dramatic increase in safety planning and management effort in the construction industry (Hill 2001). Because the industry is dynamic and transient in nature, safety management techniques must often be adjusted to meet the unique needs of the construction industry. According to Hallowell and Gambatese (2007), the current methods for selecting safety management techniques for construction projects are informal. This section of the manuscript reviews literature on the topic of construction safety management.

This literature review is divided into three main sections. First, a basic overview of safety management strategies throughout the lifecycle of a construction project is reviewed. Second, the safety program elements that have been identified by literature as “essential” are identified and described. Third, literature that quantifies and describes the relative effectiveness of the elements is summarized. One should note that this literature review is by no means comprehensive. The author refers the reader to the references at the end of this manuscript as they all provide in-depth discussions of construction safety management.

3.3.1. Construction safety management throughout the project lifecycle

The management of occupational safety and health in construction involves unique challenges. Characteristics such as fragmentation of the design and construction phases, instability of the workforce, and transient nature of construction projects contribute to disproportionate injury and illness rates (BLS 2007). Additionally, many individuals believe that the construction industry is comparatively dangerous due to stochastic events, exposure to the elements, and the inability to standardize work procedures. Despite these characteristics, a well-designed safety and health program can effectively

reduce incident rates thereby protecting the workers (Hinze 1997). Demonstrating and communicating this commitment to a well-funded and well-structured safety program is likely to reduce incidents (Hill 2001).

Effective safety programs involve the implementation of various techniques. Individual techniques intended to improve site safety are commonly referred to as safety program elements. Examples of safety program elements include a written safety and health plan, strategic subcontractor selection and management, and job hazard analyses. Collectively, these elements define a project's safety program.

Effective safety management occurs throughout a project's lifecycle. In order to educate the workforce and effectively identify, manage, and respond to safety and health hazards, organizations must include safety and health management efforts throughout each phase of the project's lifecycle. Table 3.1 provides a summary of the various efforts commonly implemented during construction projects during the design, planning, preconstruction, and construction phases. Table 3.1 identifies the specific activities that commonly occur in each phase and includes a brief description of each effort. Also, a subjective rating of each technique's ability to reduce hazardous exposure and/or reduce unsafe worker actions is provided. These ratings represent the opinion of the author and are based upon literature, particularly the work of Hinze (1997) and Hill (2001).

One should note that Table 3.1 and the subsequent discussion do not represent a comprehensive overview of the safety efforts that may be implemented in the construction industry. Rather, the author identifies a subset of common safety efforts that may exist in each of the phases of project delivery. The intention is to provide the reader with a brief overview of safety management and an appreciation of the need for safety and health management through the project lifecycle.

Table 3.1 – Objectives and abilities of safety elements

Phase	Element	Objective	Ability to reduce:	
			Unsafe worker actions	Hazardous Exposure
Design	Designing for worker safety and health	Reduce hazards by considering SH in design	None	High
	Hazard communication	Inform builders of unavoidable hazards in design	Medium	Medium
Planning	Emergency plans	Guidance for an unusually severe event	Medium	Medium
	Hazard communication program	Inform individuals of potentially hazardous materials	High	Medium
	Safety standards and regulations	Provide firm-wide safety rules	High	Low
	Safety evaluations	Increase salience of safety performance	High	Low
Pre-Const.	Job-site safety representative	Implementation of the safety program, consultation	High	High
	Site-specific safety plan	Consider site-specific challenges	Medium	Medium
	Preconstruction meetings/checklists	Consider safety before construction - all major firms	Low	High
	Subcontractor selection/compliance	Select subcontractors based on safety performance	High	Medium
Construction	Safety orientation and training	Orient workers who begin new tasks, provide training	High	Low
	Job hazard analyses	Identify and remove hazardous exposure	Low	High
	Weekly safety meetings	Discuss methods for continuous safety improvement	Low	Medium
	Toolbox talks	Review and reinforce safety mission, rules and goals	High	Low
	Substance abuse program	Reduce the frequency of substance abuse	High	Low
	Safety inspections	Inspect site for safety violations	High	High
	Accident reporting	Record and analyze information surrounding incidents	Medium	Medium
	Pre-task planning	Consideration of challenges of upcoming activities	Medium	Medium
	Schedule look-ahead	Prevent trade stacking	Low	Medium
	Industrial hygiene program	Improve worker health	Medium	High

3.3.1.1. Design

Two construction safety techniques that occur during the design phase have gained popularity in recent years. First, designing for safety, the deliberate consideration of construction worker safety in the design of a permanent facility, is becoming increasingly more common (Toole et al. 2006). Literature suggests that intervening during the design phase can remove hazards early in the project life cycle, where potential impact is the greatest. Similarly, expected hazards are typically communicated in order to alert constructors to the existence of possible hazardous exposures during construction. When alerted early, managers and workers may design the means and methods of construction in such a way that safety risk is minimized.

3.3.1.2. Planning

Several techniques implemented during the planning and conceptual phases of a project can reduce safety risks during construction. For example, emergency response planning can help reduce the potential severity during a catastrophic event. Specifically,

emergency planning requires the creation of a contingency plan for the safe response to an emergency (Hinze 1997). Other planning techniques include safety evaluations, and the consideration of safety standards and regulations.

3.3.1.3. Preconstruction

Preconstruction techniques (i.e., techniques implemented just prior to the construction phase) may include hiring a job-site safety representative, creating a site-specific safety plan, holding preconstruction meetings that specifically address potential high-risk environments, and strategic selection of subcontractors based upon their safety record. Some studies suggest that these preconstruction activities can be extremely effective (Levitt and Samelson 1987).

3.3.1.4. Construction

Most of the safety efforts implemented on a construction site occur during the construction phase. Efforts such as safety orientation and training, job hazard analyses, creation of diverse safety committees, weekly safety meetings, toolbox talks, substance abuse programs, safety inspections, accident analyses, pre-task planning and schedule look-ahead, and industrial hygiene programs can have significant impacts of safety culture and performance (Altayeb 1990; Hinze 1997; Peyton and Rubio 1991; Quayle 1988). These activities are emerging as standard procedures in the construction industry.

3.3.2. Essential elements

The previous section provided the reader with an overview of the common safety efforts that exist on contemporary construction sites throughout the lifecycle of the project. In this overview, many program elements have been discussed. As indicated, this review is not all-inclusive. In fact, in a recent study, Rajendran (2007) identifies over 100 elements.

During a comprehensive review of literature, the author identified nine publications that discuss the formation of an effective safety program. These works identify what the

author perceives to be the essential elements. As one may recall, the purpose of this manuscript is to identify the most effective program elements according to literature and to quantify their ability to reduce the probability and/or severity of the ten construction safety risk classification codes. In order to create a study that is manageable, the author has chosen to quantify risk mitigation only for the safety program elements previously identified as the most effective. These elements are identified and described in sections 3.3.2.1 through 3.3.2.13.

During a thorough literature review the author identifies only sixteen elements. Of these sixteen elements, thirteen were mentioned as essential components of a safety program in four or more of the nine publications reviewed. Table 3.2 identifies these thirteen program elements. In this table a “1” indicates that the element was mentioned as essential in the publication and a “0” indicates that the element is not mentioned. Using the references identified in Table 3.2 as guidance, the following sections (Section 3.3.2.1 through 3.3.2.13) provide the reader with a list and description of the thirteen essential safety program elements. This list with descriptions is used in subsequent research efforts described in this manuscript and is an essential component of the safety equilibrium model.

Table 3.2 – Essential Safety Program Elements

Safety Program Element	OSHA (2007)	Meridian Research (1994)	Liska (1993)	Jaselskis (1996)	Hinze et al. (2001)	Gibb et al. (2004)	Hinze (1997)	Hill et al. (2001)	Rajendran (2006)	Total
Upper management support / commitment	1	0	0	1	1	0	1	1	1	6
Job hazard analyses and communication	1	1	0	0	0	0	1	1	1	5
Safety and health orientation and training	1	0	1	1	1	0	1	1	1	7
Written and comprehensive safety and health plan	0	1	0	1	1	0	1	1	1	6
Frequent worksite inspections (self and OSHA consult)	0	1	0	1	0	0	1	1	1	5
Emergency response planning	0	1	0	0	1	0	1	0	1	4
Record keeping and accident analyses	0	1	1	0	1	0	1	1	1	6
Training and regular safety meetings	0	1	0	0	0	0	1	1	1	4
Safety and health committees	0	1	1	0	0	0	1	0	1	4
Substance abuse programs	0	0	1	0	1	0	1	0	1	4
Safety manager on site (staffing for safety)	0	0	0	0	1	0	1	1	1	4
Subcontractor selection and management	0	0	0	1	1	1	1	1	1	6
Employee involvement in safety mgt. and planning	0	1	0	0	1	0	1	1	1	5

3.3.2.1. *Written and comprehensive safety and health plan*

A safety and health plan serves as the foundation for an effective safety and health program. A written safety and health plan involves the documentation of project-specific safety and health objectives, goals and methods for achieving success. This element should be specific to the project. Additionally, the firm should have a written safety and health plan that defines the safety and health objectives, goals and direction of the firm as a whole.

3.3.2.2. *Upper management support and commitment*

Participation and commitment of upper management involves the explicit consideration of worker safety and health as a primary goal of the firm. Upper management must regard worker safety and health as a fundamental goal and demonstrate commitment by participating in regular safety meetings, serving on committees, providing funding for other safety and health program elements. Upper management support and commitment must be demonstrated by actions and funding, not only in writing and rhetoric.

3.3.2.3. *Job hazard analyses and hazard communication*

Contractors may begin a job hazard analysis by reviewing the activities associated with a construction process and identifying potential hazardous exposures that may lead to an injury. Other sources such as OSHA logs, violation reports, accident investigation reports, interviews with laborers or simply intuition may be used to identify hazards. A critical component of this safety program element is that once hazards are identified, they are communicated to the workers.

3.3.2.4. *Safety and health orientation and training*

The orientation of all new hires may be the most important safety training. Even skilled and experienced workers should be provided with a firm-specific safety and health orientation and training. Such training and orientation informs new hires of company safety goals, policies, programs, resources, etc. This element involves the firm-specific,

but not necessarily project-specific, orientation and training of all new hires (or existing employees if a safety and health program is new to the firm).

3.3.2.5. *Frequent worksite inspections*

Worksite inspections may be performed internally by a contractor's safety manager, safety committee, representative of the contractor's insurance provider or by an OSHA consultant. The purpose of a safety and health inspection is to identify uncontrolled hazardous exposures to workers, violations of safety standards or OSHA regulations or the unsafe behavior of workers. Inspections must occur on a regular basis.

3.3.2.6. *Emergency response planning*

This safety program element involves the creation of a plan to follow in the case of a serious incident such as a fatality or an incident involving multiple serious injuries. Planning for emergencies can define the difference between an accident and a catastrophic event. Such a plan may be required by the Owner or insurance carrier.

3.3.2.7. *Record keeping and accident analyses*

This safety program element involves documenting and reporting the specifics of all accidents including information such as time, location, work-site conditions or cause. The element also includes the analyses of accident data to reveal trends, points of weakness in the firm's safety program, or poor execution of program elements.

3.3.2.8. *Project-specific training and regular safety meetings*

This element involves the establishment and communication of project-specific safety goals, plans and policies before the start of the project. Safety training may include reviewing project-specific or task-specific hazard communication, methods of safe work behavior, company policies, safety and health goals, etc. This element also involves the regular safety meetings such as toolbox talks to reinforce and refresh safety and health training.

3.3.2.9. *Safety and health committees*

A committee made up of supervisors, laborers, representatives of key subcontractors, owner representatives, OSHA consultants, etc. may be formed with the sole purpose of addressing safety and health on the worksite. Such a committee must hold regular (e.g. weekly or bi-weekly) meetings to address safety and health by performing inspections, discussing job hazard analyses or directing safety meetings and training.

3.3.2.10. *Substance abuse programs*

This safety program element targets the identification and prevention of substance abuse. Testing is a crucial component of this safety program element. Methods of testing and consequences of failure may differ from one firm to another. However, repeated violations are typically grounds for dismissal of the employee. Testing may occur on a regular or random basis and always for employees involved with an incident that involves a medical case or lost work-time injury or fatality.

3.3.2.11. *Safety manager on site*

Simply, this safety program element involves the employment of a safety and health professional (i.e., an individual with construction safety and health experience and/or education). This individual's primary responsibility is to perform and direct safety and health program elements (e.g., accident investigation, inspections, orientation) and to serve as a safety and health resource for employees.

3.3.2.12. *Subcontractor selection and management*

This element involves the consideration of safety and health performance during the selection of subcontractors. That is, only subcontractors with demonstrated ability to work safely should be considered during the bidding or negotiating process. Once a contract is awarded, the subcontractor must be required to comply with the minimum requirements of the general contractor's safety and health program.

3.3.2.13. *Employee involvement and evaluation in safety management and planning*

Employee involvement and evaluation is a means of including all employees in the formulation and execution of other safety program elements. Involvement in safety and health activities may include activities such as performing job hazard analyses, participating in toolbox talks or performing inspections. Evaluation of employees' safety performance involves considering safety metrics during regular employee performance evaluations. This may include the consideration of incident frequency, inspection results and consideration of near misses.

3.3.3. Relative effectiveness of safety program elements

One of the secondary objectives of this manuscript is to identify the relative effectiveness of safety program elements. Only one study identified by the author attempts to perform research related to this topic. Rajendran (2007) performed research and created a sustainable construction safety and health rating system. In this study, Rajendran identified the elements that are essential for ensuring a high level of safety. Additionally, this rating system provides relative ratings of effectiveness. The resulting Sustainable Construction Safety and Health (SCSH) Rating System has been reproduced with permission in Figure 3.2.

As one can clearly see, Rajendran (2007) indicates that the most effective elements (i.e., elements with > 2.3 credits) are as follows:

1. Competent personnel for all high risk tasks (2.4)
2. Contractor selection (2.3)
3. Subcontractor selection (2.3)
4. Management Commitment to Safety and Health (2.3)
5. Safety and Health During Conceptual Planning Phase (2.3)

6. Constructability Review (2.3)
7. Job Hazard Analysis (2.3)
8. Pre-task Planning (2.3)
9. Employees Empowered with Stop Authority (2.3)

While this study identifies the top-tier program elements, it does not distinguish among these highly effective elements nor does it identify how much risk the program elements reduce. Therefore, further research that distinguishes among these highly-effective elements and quantifies the risk mitigation capacity is needed. The following sections of this Manuscript describe the methods, results, and analysis of a study that aims to perform such research.

Project Team Selection			6.6 Possible Credits
R	Element 1.1	Constructor Selection	2.3
R	Element 1.2	Subcontractor Selection	2.3
E	Element 1.3	Designer Selection	2.0
Safety and Health in Contracts			5.5 Possible Credits
R	Element 2.1	Safety and Health in Contracts	2.2
E	Element 2.2	Safety Hazard Symbols in Construction Drawings	1.6
E	Element 2.3	Specification of Less Hazardous Materials	1.7
Safety and Health Professionals			8.1 Possible Credits
R	Element 3.1	Competent Personnel for All High Hazard Tasks	2.4
E	Element 3.2	Owner Safety Representative	1.8
E	Element 3.3	Constructor Safety Representative	2.0
E	Element 3.4	Subcontractor Safety Representative	1.9
Safety Commitment			4.3 Possible Credits
R	Element 4.1	Management Commitment to Safety and Health	2.3
R	Element 4.2	Owner/Representative Commitment to Safety and Health	2.0
Safety Planning			27.8 Possible Credits
R	Element 5.1	Safety and Health During Conceptual Planning Phase	2.3
R	Element 5.2	Constructability Review	2.3
R	Element 5.3	Designing for Worker Safety and Health	2.2
R	Element 5.4	Life Cycle Safety Design Review (LCS)	2.0
R	Element 5.5	Safety Checklist for Designers	2.1
R	Element 5.6	Constructor Site Specific Safety Plan	2.0
R	Element 5.7	Subcontractor Site Specific Safety Plan	2.1
R	Element 5.8	Job Hazard Analysis	2.3
R	Element 5.9	Pre-task Planning	2.3
R	Element 5.10	Look Ahead Schedule	2.1
R	Element 5.11	On and Off site Traffic Plan	2.1
R	Element 5.12	Good housekeeping Plan	2.2
E	Element 5.13	Personnel Protection Equipment (PPE) Plan	1.8
Training and Education			15.3 Possible Credits
R	Element 6.1	Safety Training for Designers	2.0
R	Element 6.2	Safety Orientation for All Workers	2.0
E	Element 6.3	Safety Training for All Field Supervisors (OSHA 30 hour)	2.0
E	Element 6.4	OSHA 10-hour Training for All Workers	1.8
E	Element 6.5	Assessment of All Equipment Operators Skills and Training	1.8
E	Element 6.6	Toolbox Meetings	1.8

Figure 3.2 – Sustainable Construction Safety and Health (SCSH) Rating System
(Rajendran 2007)
(R = Required, E = Elective)

E	Element 6.7	Regular Safety Training for All Project Personnel	2.0
E	Element 6.8	Constructor Mentors Subs to Improve Safety Performance	1.9
Safety Resources		1.8 Possible Credits	
E	Element 7.1	Task-based Hazard Exposure Database	1.8
Drug and Alcohol Program		1.8 Possible Credits	
E	Element 8.1	Drug and Alcohol Testing Program	1.8
Accident Investigation and Reporting		3.7 Possible Credits	
R	Element 9.1	Accident and Near Miss Investigation	2.0
E	Credit 9.2	Accident and Near Miss Investigation with Pre-task and JHA	1.7
Employee Involvement		4.2 Possible Credits	
R	Element 10.1	Employees Empowered with Stop Authority	2.3
E	Element 10.2	Employee Safety Committee and Leadership Team	1.9
Safety Inspection		3.8 Possible Credits	
E	Element 11.1	Safety Inspections	2.0
E	Element 11.2	Safety Violations identified and corrected	1.8
Safety Accountability and Performance Measurement		8.0 Possible Credits	
R	Element 12.1	Project Accountability and Responsibility	2.4
R	Element 12.2	Supervisors Evaluated Based on Safety Performance	2.2
E	Element 12.3	Safety Performance Evaluation using Safety Metrics	1.9
E	Element 12.4	Contractor Evaluation Based on Safety Performance	1.5
Industrial Hygiene Practices		9.1 Possible Credits	
R	Element 13.1	Engineering Controls for Health Hazards	2.1
E	Element 13.2	Hearing Protection Program	1.6
E	Element 13.3	Respiratory Protection Program	1.9
E	Element 13.4	Stretch and Flex Program	1.5
E	Element 13.5	Ergonomic Task Analysis and Remediation	2.0
Project Total		100 Possible Credits	
Certified 54.5 credits; Silver 54.6-75.0 credits; Gold 75.1-90.0 credits; Platinum 90.1-100.0 credits			
All required elements to be fulfilled for all levels of certification			

Figure 3.2 - Sustainable Construction Safety and Health (SCSH) Rating System, (continued)

3.4. METHODOLOGY

The Delphi technique was chosen as the research method to determine the risk mitigation associated with the implementation of the thirteen essential safety program elements identified in the previous section of this Manuscript. Section 2.4.2 provides a comprehensive overview of the Delphi method including the history, structure, applicability, and specific design of the method for this study. Furthermore, Section

2.4.2.3 reviews common judgment-based biases and identifies how these biases are controlled for this study. The author refers the reader to Section 2.4.2 for a complete review of the Delphi research method and an overview of the structure of the method for this study. Please note, the research method implemented to collect the data presented in this manuscript is identical to that outlined in Manuscript 2. A brief discussion of the applicability of the Delphi method to this portion of the study is outlined below.

3.4.1. Applicability of the Delphi Method

As indicated in previous manuscripts, the dynamic and transient nature of construction projects makes construction engineering and management research particularly challenging. The presence of many confounding factors and the general nature of construction safety and health research make many conventional research methods unrealistic. The data collection required for this research, for example, involves the quantification of the risk mitigation associated with the implementation of various safety program elements. Quantifying these values in an objective fashion would be extremely difficult due to the presence of many confounding factors. Furthermore, to obtain adequate confidence in the values and their applicability to the US construction industry as a whole, an extremely high volume of data would be required. Therefore, the author believes that the Delphi method is applicable to this study because the technique allows researchers to maintain significant control over bias in a well-structured, academically-rigorous process using the judgment of qualified experts.

To review, the Delphi method is defined as a systematic and interactive research technique for obtaining the judgment of a panel of independent experts on a specific topic. Individuals are selected according to predefined guidelines and are asked to participate in two or more rounds of structured surveys. After each round, the facilitator provides an anonymous summary of the experts' input from the previous survey. In each subsequent round, participants are encouraged to review the anonymous opinion of the other panelists and consider revising their previous response. During this process the

variability of the responses will decrease and group consensus will be achieved. Finally, the process is concluded after a pre-defined criterion (e.g., number of rounds, achievement of consensus, etc.) is met and the mean or median scores of the final round determine the results. The Delphi method is particularly useful when objective data is unattainable, there is a lack of empirical evidence, experimental research is unrealistic or unethical, or when the heterogeneity of the participants must be preserved to assure validity of the results.

During the Delphi process expert panelists are asked to rate the ability of each safety program element to reduce a portion of the ten safety risk codes described in Section 2.3.2.1. The goal of the study is to achieve consensus among a group of experts through the use of multiple round and controlled feedback. Unlike the ratings obtained in the previous manuscript, the values described in this manuscript represent risk mitigation. The following section will discuss the method implemented in this study to quantify risk mitigation.

3.4.2. Risk mitigation quantification

As reviewed in Section 2.3.1, risk quantification requires the independent quantification of probability and severity. The product of probability and severity provides an individual with a unit risk level (i.e., risk per worker-hour). Multiplying this value by exposure (i.e., worker-hours) provides one with a cumulative risk value defined in terms of severity. Risk mitigation, however, involves the quantification of *reduction* in probability and the *reduction* in severity. Therefore, unit risk mitigation may be calculated by multiplying the reduction in probability (i.e., decrease in number of incidents per worker-hour) by the reduction in severity (i.e., reduction in average severity per incident). The risk scales introduced in Section 2.4.2.5 will be incorporated into this component of the study as well.

For each of the essential safety program elements the experts were asked to use their experience and judgment to rate what they believe the average reduction in probability and/or severity of an injury may be for each of the provided safety risk hazard codes. The experts were asked to rate using the following probability and severity scales (Tables 3.4 and 3.5) for reference when rating the probability and severity reduction for construction incidents.

Table 3.4 – Probability mitigation scale

Probability: Average <i>increase</i> in worker-hours per incident as a result of safety element									
0 or negligible	1-10	10-100	10-1,000	1,000-10,000	10,000-100,000	100,000-1 million	1 million-10 million	10 million to 100 million	> 100 million
1	2	3	4	5	6	7	8	9	10

Table 3.5 – Severity mitigation scale

Severity: Loss scale associated with an incident									
0 or negligible	Discomfort → Persistent Pain				Medical case		Lost work time		Death
1	2	3	4	5	6	7	8	9	10

One may note that using the scales to rate probability and severity mitigation is quite confusing. Therefore, the author provided the expert panel with detailed instructions for using the scales. For example, if an expert believed a particular safety program element is capable of reducing the average probability of transportation incidents from one incident per 50 worker hours (2) to one incident per 3,000 worker hours (4), they were asked to rate the probability mitigation as a '2' ($4-2 = 2$). Likewise, if an expert believed a safety program element may reduce the severity of falls to a lower level from significant lost work-time (9) to a high level of persistent pain (5), please rate the severity mitigation a '4' ($9-5 = 4$). Great care was taken to ensure that the experts understood the ratings that they were being asked to provide and phone conversations or e-mail correspondence was used to explain the ratings.

3.5. RESULTS

This section of the manuscript is devoted to the presentation of the raw results obtained through the Delphi process. The results of each round will be presented in order and the final probability reduction, severity reduction, and risk reduction values will be included in the manuscript body. The analysis section of this report will analyze the findings and present them in a format that will be useful to the construction industry.

3.5.1. Risk Mitigation (Delphi Results)

The results of the Delphi risk mitigation ratings are presented in this section. Because the Delphi process for this study involved the use of three rounds of data collection and an introductory survey, this section is divided into four main sections: introductory survey results, Round 1 results, Round 2 results, and Round 3 results. The salient aspects of the first two rounds are summarized in this section. The results of Round 3 are presented and discussed in detail, as they represent the final results of the process. The Round 3 results are also analyzed and validated in subsequent sections.

3.5.1.1. *Introductory Survey Results*

As indicated in Section 2.5.1.1, potential experts were identified in several ways. Individuals that currently participate on construction safety or risk management-related committees such as the American Society of Civil Engineers' Construction Site Safety Committee, have published books or journal articles on the topic of construction safety or risk management, or have participated in Delphi studies on the topic in the past were contacted and asked to participate. In total, 63 potential experts were identified.

Via e-mail, potential experts were given the details of the study including a brief description of the potential commitment and purpose of the study. Potential experts were also asked to complete a brief introductory survey. The primary purpose of the introductory survey was to confirm individuals as experts according to the guidelines in literature (summarized in Section 2.4.2.4.1).

Of the 63 individuals contacted, 31 individuals agreed to participate, resulting in a participation rate of 49 percent. Of the 31 individuals who agreed to participate, 29 were certified as experts in the field of construction safety and risk management. In order to be certified as an expert, each individual was required to meet at least four requirements listed in Section 2.4.2.4.1.

Since this research involves the development of two distinct Delphi panels, the 29 certified experts were randomly assigned to one of two panels. Using a random number generator in Microsoft Excel®, each certified expert was assigned a random number between 0 and 1. These numbers were then ranked from one to 29, where 1 represented the highest of the randomly-generated numbers and 29 represented the lowest. The first fourteen experts were assigned to participate in the risk demand quantification panel (the results of which are summarized in Manuscript 2). The remaining 15 experts (ranked from 15 to 29) were asked to participate in the quantification of the risk mitigation capacity of common safety program elements. The demographics of the Delphi panel that was responsible for the quantification of risk mitigation associated with the implementation of essential safety program elements are presented in Table 3.6. Panelist names have been removed to maintain anonymity and have been replaced with a participant ID number. One should note that only the demographic information for the panelists who completed all phases of the study are shown.

Table 3.6 – Delphi capacity panel expert characteristics

ID	State	Country	Terminal Degree	Academic Position	Peer-reviewed Journals	Book or Book chapters	Years Industry Exp.	Licensure
C1	MO	USA	BS	None	2	1	35	PE
C2	WA	USA	MBA	None	0	0	32	PE
C3	OR	USA	MS	Ass't Professor	0	1	17	None
C4	GA	USA	BS	Lecturer	5	0	25	None
C5	IL	USA	MS	Assoc. Professor	0	2	30	PE, CSP
C6	OR	USA	BS	None	4	2	20	PE
C7	CA	USA	BS	None	0	1	47	PE
C8	MI	USA	PhD	Assoc. Professor	8	0	8	None
C9	OR	USA	MS	None	0	4	32	CSP, ARM
C10	OR	USA	BS	None	0	0	32	CSP

As one can see from Table 3.6, the participants come from seven different states and almost every major geographical region of the United States. All of the panelists who participated in the Demand Delphi panel have a degree from an accredited program in an institution of higher learning, and 4 of 10 (40%) of the panelists have a graduate degree in a civil engineering, construction engineering and management (CEM), occupational safety and health, or risk management.

The most important aspect of Table 3.6 is the cumulative experience of the panel because the results of this study represent the consensus of these individuals. The collective qualifications of this Delphi panel are as follows:

- A large range of geographical regions are represented
- One individual possesses a Ph.D., three possess a M.S., and five possess a B.S. as their terminal degree in a related field of study
- Two individuals are employed at the associate professor rank and one is employed as at the assistant professor rank at an accredited academic institution
- The panel has produced a total of 19 publications in peer-reviewed journals on the topic of construction safety and health or risk management

- The panel has produced 11 books on the topic of construction safety and health or risk management
- The panel has over 278 years of field experience in the construction industry
- The panelists have obtained five P.E. licenses, three C.S.P. license, and one A.R.M. license

Once certified as experts according to literature, the Delphi process continued with the transmission of the first round of surveys. An overview of the specific survey process is included in the following sections.

3.5.1.2. Delphi Round 1 Results

The certified experts were asked to complete an undefined number of surveys with the goal of achieving consensus. Since the objective of the surveys was to determine the safety risk capacity associated with the implementation of safety program elements, the panel was asked to rate the probability reduction and severity reduction for each safety risk code resulting from the implementation of each safety program element. The ten incident codes used for this study are defined in Section 2.3.2.1 and the thirteen safety program elements analyzed are described in Section 3.3.2. In total, experts were asked to rate 260 different combinations (2 components x 10 incident types x 13 safety program elements = 260 ratings per round). An example of the survey forms used for Round 1 is provided in Appendix F.

Some salient aspects of the Round 1 Capacity survey are as follows:

- The order of activities presented on the form was organized randomly for each panelist's custom form using the random number generator in MS Excel®. For each panelist the safety program elements were assigned a random number. The random numbers were ranked from highest to lowest and the order of the ranks determined the order to the activities on the survey form.

- The order of the 10 potential safety risks was randomized for each panelist using a random number generator in MS Excel®. For each panelist, the safety risks were assigned a random number. The random numbers were ranked from highest to lowest. The order of the ranks determined the order of the safety risks on the survey form.
- Panelists were provided with the incident classification descriptions and the safety program element descriptions
- Panelists were asked to provide ratings for the average ability of an element to reduce the probability and/or the average severity for the industry in general using their expert judgment
- Panelists were asked to provide probability and severity reduction ratings considering a scenario where no other safety program elements are implemented
- Panelists were provided with probability and severity reduction scales introduced in Section 3.4.2.

An example Round 1 form, sent to an expert panelist is provided in Appendix F. This form is representative of all of the other survey forms, except the order of the activities and the order of the safety risks is unique for each panelist.

Eleven of the fourteen panelists completed the first round survey. The median values for each probability score and each severity score represent the results of the round. As indicated in Section 2.4.2.4.7, median values were used to minimize the effects of potentially biased individuals. The variation in the responses is represented by the absolute median calculated using Equation 2.2. A summary of the results (medians values only) can be found in Tables 3.7 and 3.8.

Table 3.7 – Median probability reduction ratings obtained through the Delphi process

	PROBABILITY REDUCTION										
	Struck-by	Struck-against	Caught-in	Fall to Lower	Fall to Same	Over-exertion	Repetitive Motion	Exposure to Harmful Substances	Transportation Accidents	Other	
Upper Management support and commitment	6	6	6	7	4	5	4	6	5	5	
Written and comprehensive safety and health plan	5	5	4	5	5	3	3	5	4	3	
Project-specific training and regular safety meetings	5	5	5	6	5	5	5	6	5	4	
Employee involvement and evaluation in safety mgt and planning	6	5	6	6	6	5	5	6	5	4	
Subcontractor selection and management	6	5	5	7	5	4	4	6	6	4	
Job hazard analysis and hazard communication	6	5	6	6	5	5	5	6	5	5	
Record keeping and accident analysis	3	2	3	3	3	3	3	3	3	2	
Emergency response planning	2	2	2	2	2	2	2	2	3	2	
Frequent worksite inspections	5	5	5	6	5	5	5	5	5	5	
Safety and health committees	5	5	5	5	5	4	5	5	5	4	
Safety and health orientation and training	5	5	5	5	5	4	4	5	5	3	
Substance abuse programs	5	5	5	5	5	5	3	5	5	5	
Safety manager on site	5	5	5	5	5	5	5	6	5	4	

Table 3.8 – Median severity reduction ratings obtained through the Delphi process

	SEVERITY REDUCTION										
	Incident Type										
	Struck-by	Struck-against	Caught-in	Fall to Lower	Fall to Same	Over-exertion	Repetitive Motion	Exposure to Harmful Substances	Transportation Accidents	Other	
Upper Management support and commitment	5	4	4	6	4	4	4	5	4	4	
Written and comprehensive safety and health plan	3	3	3	4	3	2	2	3	3	2	
Project-specific training and regular safety meetings	5	4	4	6	4	4	4	6	4	3	
Employee involvement and evaluation in safety mgt and planning	5	5	4	4	4	4	4	5	5	4	
Subcontractor selection and management	4	4	4	6	3	3	3	4	4	3	
Job hazard analysis and hazard communication	4	4	4	5	4	4	4	4	4	4	
Record keeping and accident analysis	3	2	3	3	2	2	2	3	2	2	
Emergency response planning	4	3	3	4	2	3	1	3	3	2	
Frequent worksite inspections	5	5	4	5	4	4	3	4	5	3	
Safety and health committees	4	3	3	4	3	3	3	4	3	3	
Safety and health orientation and training	3	3	3	4	3	3	3	4	3	3	
Substance abuse programs	5	4	4	4	4	3	3	4	4	3	
Safety manager on site	4	4	4	5	4	4	4	5	5	3	

The values in Tables 3.7 and 3.8 correspond to the scales provided to the panelists (introduced and described in Section 3.4.2). The analysis section of this manuscript presents the data and analyses in useable units of probability, severity, and risk.

One of the goals of this study is to achieve consensus among the expert panelists. The raw results of Round 1 include the absolute median for each rating. As one can see from this summary, there is some deviation in the results. The average of all of these deviations (i.e., the average of all of the absolute deviations) is 1.72 units for probability ratings and 1.80 for severity ratings. In other words, the absolute median for all of the probability ratings is 1.72 units and the absolute median for all of the severity ratings was 1.80 units. Since group consensus of the experts is vital to the quality and precision of the results, Rounds 2 and 3 will focus on reducing the variation in the expert responses and obtaining the true probability and severity values.

3.5.1.3. *Delphi Round 2 Results*

The process implemented to conduct the second round of the Delphi process was very similar to Round 1. In order to further reduce judgment-based biases that may occur due to the order of risks and activities listed on the forms (e.g., primacy, contrast), the order of the activities was randomized once again. Also, the order of the risks was re-randomized. Both randomizations were achieved by using the Microsoft Excel® random number generator using the same method as in Round 1. Respondents were also given the same background information as in Round 1 (e.g., probability scale, severity scale, activity descriptions, and safety risk descriptions). However, the directions were slightly different from the first round and the panelists were given anonymous feedback. An augmented version of a Round 2 survey is provided in Appendix G for reference.

Round 2 differed from Round 1 in the following ways:

- Respondents were provided with their rating from Round 1 and the median rating from Round 1 (the symbol || on the form represents the median response from the previous round)
- Respondents were specifically requested to consider the group median and re-consider their Round 1 ratings given the collective group statistic.
- Respondents were asked to provide reasons for outlying responses if their chosen Round 2 response is two or more units from the Round 1 median response.

Surprisingly, the medians that resulted from Round 2 were identical to those from Round 1 (for Round 1 responses, see Tables 3.6 and 3.7) despite the fact that many of the expert panelists chose to change their Round 1 responses. Experts tended to choose ratings that were closer to the Round 1 median response. This is illustrated by the fact that, for Round 2, the absolute median for all probability ratings was 0.95 units and the absolute median for the severity ratings was 0.94. One should note that the variance was nearly twice as high in the first round indicating that the experts came much closer to consensus.

Between Round 1 and Round 2, one of the remaining eleven panelists failed to respond to the survey resulting in a total pool of 10 experts who completed Round 2. The default of four members (during the course of the three rounds) was not considered detrimental for two reasons: (1) literature suggests that 8 to 15 panel members is an ideal panel size, and (2) the input of the four members who defaulted was still incorporated into the study.

In an effort to achieve even greater consensus, the author believed that extending the Delphi study to a third round and providing the expert panelists with reasons for outlying responses was important for achieving the highest quality results. This decision was also made based on the compelling comments made by the panelists on specific issues. On these Round 3 forms the reasons for outlying responses (i.e., ratings two or more units from the median) and the value for the outlying responses are provided in the end notes to the ratings table for each activity. The reader is encouraged to review these comments as

they provide insight to the expert's opinions and explain some of the variation in response.

3.5.1.4. Delphi Round 3 Results

As indicated in the previous section, the author determined that a third round of Delphi surveys would strengthen the study as the expert panelists could review the anonymous reasons for outlying responses. The process implemented for Round 3 was the same as Rounds 1 and 2 as the order of the activities and the order of the safety risks were re-randomized to ensure minimum bias. Also, like Round 2, the panelists were provided with the median response from the previous round which, coincidentally, was the same as Round 1. In Round 3, the panelists were also provided with the reasons for outlying responses from Round 2. One should note that all feedback (i.e., median responses and reasons) is anonymous. In other words, no comments or ratings were ever accompanied by information that would identify the panelists to one another. This anonymity was ensured to eliminate the possibility of bias due to dominance. An augmented version of a Round 3 survey is provided in Appendix H.

While many of the ratings changed from Rounds 2 to 3, especially those for the categories where panelists provided compelling reasons for their outlying responses, none of the median values changed. Therefore, the median values presented in Tables 3.6 and 3.7 represent a summary of the final results of the safety risk mitigation quantification panel. These values, when interpreted with the scales, represent the safety risk capacity.

While the median values did not change, the expert panel came closer to achieving consensus. The absolute median for all of the probability reduction ratings is 0.83 units and the absolute median for all of the severity reduction values is 0.81. These values indicate that the absolute deviation of all responses is less than the original target of 1. The author believes that this level of consensus is sufficient for this study due to the complex nature of the research question, the confounding factors that lead to safety risk

ratings, and the variability in experiences among safety experts. Recalling the target consensus value from Section 2.4.2.4.6, the results from the Delphi process was nearly 75 percent of the target variance of an absolute median of 1 unit. Additionally, all 13 members from Round 2 completed a Round 3 survey. The following section will discuss the achievement of sufficient consensus in the Delphi process.

3.5.1.5. Consensus

To measure the consensus for each rating, the absolute median was tracked. Additionally, the average of all of these values was used to represent the degree of consensus of the entire survey round. As previously indicated, the goal for consensus for this study was to have an absolute deviation (for the entire round) of 1 unit or less. The absolute deviation for all capacity ratings, including both probability reduction and severity reduction, was 0.82 units.

3.6. ANALYSIS

This section of the manuscript presents an interpretation of the data and an analysis of the results presented in the previous section. The raw results of the data (i.e., median probability and median severity values, rated on a 1 to 10 scale) are interpreted using the appropriate scales and graphically analyzed. The objective of this section is to determine the safety program elements that mitigate the greatest proportion of safety risk and identify the total portion of risk mitigated by all thirteen safety program elements.

3.6.1. Conversion to Appropriate Probability Units

According to Section 2.6.1, the probability values must be converted to appropriate units prior to analysis. The raw probability data (i.e., 1-10 ratings) are converted through the following steps:

1. Convert the scaled 1 to 10 values to actual terms of probability using the probability scale provided to the Delphi panel.

2. Find the mid-point of each range (e.g., an increase of 0.1 to 1 worker-hours per incident becomes an increase of 0.55 worker hours per incident)
3. Convert probability reduction values from increase in worker-hours per incident to a decrease in incidents per worker-hour by finding the inverse of the values determined in step 2 (e.g., an increase of 0.55 worker-hours per incident becomes a decrease of 1.8 incidents per worker-hour).

The steps required to convert the probability values are illustrated in Table 2.10. One should note that the values were converted because the original 1 to 10 values do not accurately represent the probability values in the scales. Each of the probability ratings in Table 3.9 were converted to useable probability values using the three steps described above. The resulting probability values can be found in Table 3.10.

Table 3.9 – Probability conversions

Scale value	Original Range provided to Delphi (worker-hours)	Increase in Worker-hours per incident	Decrease in probability
1	Negligible	Negligible	0.0E+00
2	0.1 to 1	0.55	1.8E-08
3	1 to 10	5.50	1.8E-07
4	10 to 100	55.00	1.8E-06
5	100 to 1,000	550.00	1.8E-05
6	1,000 to 10,000	5,500.00	1.8E-04
7	10,000 to 100,000	55,000.00	1.8E-03
8	100,000 to 1,000,000	550,000.00	1.8E-02
9	1,000,000 to 10,000,000	5,500,000.00	1.8E-01
10	10,000,000 to 100,000,000	55,000,000.00	1.8E-00

Table 3.10 – Probability reduction ratings (increase in s per worker-hour)

	PROBABILITY REDUCTION										
	Incident Type										
	Struck-by	Struck-against	Caught-in	Fall to Lower	Fall to Same	Overexertion	Repetitive Motion	Exposure to Harmful Substances	Transportation Accidents	Other	
Upper Management support and commitment	1.8E-04	1.8E-04	1.8E-04	1.8E-03	1.8E-06	1.8E-05	1.8E-06	1.8E-04	1.8E-05	1.8E-05	
Written and comprehensive safety and health plan	1.8E-05	1.8E-05	1.8E-06	1.8E-05	1.8E-05	1.8E-07	1.8E-07	1.8E-05	1.8E-06	1.8E-07	
Project-specific training and regular safety meetings	1.8E-05	1.8E-05	1.8E-05	1.8E-04	1.8E-05	1.8E-05	1.8E-05	1.8E-04	1.8E-05	1.8E-06	
Employee involvement and evaluation in safety management and planning	1.8E-04	1.8E-05	1.8E-04	1.8E-04	1.8E-04	1.8E-05	1.8E-05	1.8E-04	1.8E-05	1.8E-06	
Subcontractor selection and management	1.8E-04	1.8E-05	1.8E-05	1.8E-03	1.8E-05	1.8E-06	1.8E-06	1.8E-04	1.8E-04	1.8E-06	
Job hazard analysis and hazard communication	1.8E-04	1.8E-05	1.8E-04	1.8E-04	1.8E-05	1.8E-05	1.8E-05	1.8E-04	1.8E-05	1.8E-05	
Record keeping and accident analysis	1.8E-07	1.8E-08	1.8E-07	1.8E-07	1.8E-07	1.8E-07	1.8E-07	1.8E-07	1.8E-07	1.8E-08	
Emergency response planning	1.8E-08	1.8E-08	1.8E-08	1.8E-08	1.8E-08	1.8E-08	1.8E-08	1.8E-08	1.8E-07	1.8E-08	
Frequent worksite inspections	1.8E-05	1.8E-05	1.8E-05	1.8E-04	1.8E-05	1.8E-05	1.8E-05	1.8E-05	1.8E-05	1.8E-05	
Safety and health committees	1.8E-05	1.8E-05	1.8E-05	1.8E-05	1.8E-05	1.8E-06	1.8E-05	1.8E-05	1.8E-05	1.8E-06	
Safety and health orientation and training	1.8E-05	1.8E-05	1.8E-05	1.8E-05	1.8E-05	1.8E-06	1.8E-06	1.8E-05	1.8E-05	1.8E-07	
Substance abuse programs	1.8E-05	1.8E-05	1.8E-05	1.8E-05	1.8E-05	1.8E-05	1.8E-07	1.8E-05	1.8E-05	1.8E-05	
Safety manager on site	1.8E-05	1.8E-05	1.8E-05	1.8E-05	1.8E-05	1.8E-05	1.8E-05	1.8E-04	1.8E-05	1.8E-06	

3.6.2. Resulting Risk Values

Previous discussion alluded to the fact that the risk mitigation score for a safety program element may be calculated by finding the product of probability reduction and severity reduction. Therefore, the resulting risk values for this study can be defined as the product of Tables 3.7 and 3.8. The values in the resulting matrix (Table 3.11) have units of reduction in severity per worker in a one hour work period. In other words, the values represent the risk mitigation ability of the essential safety program elements.

The results summarized in Table 3.11 represent the ultimate objective of this manuscript as the risk mitigation associated with each safety program element has been adequately quantified through a rigorous Delphi study. While the resulting data is compelling in its own right, the data is briefly analyzed to determine the total risk mitigated by each safety program element.

Table 3.11 – Risk mitigation scores

Safety Program Element	Risk Reduction: (Risk reduction score)									
	Struck- by	Struck- against	Caught- in	Fall to Lower	Fall to Same	Over- exertion	Repetitive Motion	Exposure to Harmful Substances	Transportation Accidents	Other
Upper Mgt Support	9.1E-04	7.3E-04	7.3E-04	1.1E-02	7.3E-06	7.3E-05	7.3E-06	9.1E-04	7.3E-05	7.3E-05
Written safety plan	5.5E-05	5.5E-05	5.5E-06	7.3E-05	5.5E-05	3.6E-07	3.6E-07	5.5E-05	5.5E-06	3.6E-07
Training and regular safety meetings	9.1E-05	7.3E-05	7.3E-05	1.1E-03	7.3E-05	7.3E-05	7.3E-05	1.1E-03	7.3E-05	5.5E-06
Employee involvement	9.1E-04	9.1E-05	7.3E-04	7.3E-04	7.3E-04	7.3E-05	7.3E-05	9.1E-04	9.1E-05	7.3E-06
Subcontractor selection and mgt	7.3E-04	7.3E-05	7.3E-05	1.1E-02	5.5E-05	5.5E-06	5.5E-06	7.3E-04	7.3E-04	5.5E-06
Job hazard analyses	7.3E-04	7.3E-05	7.3E-04	9.1E-04	7.3E-05	7.3E-05	7.3E-05	7.3E-04	7.3E-05	7.3E-05
Record keeping and accident analysis	5.5E-07	3.6E-08	5.5E-07	5.5E-07	3.6E-07	3.6E-07	3.6E-07	5.5E-07	3.6E-07	3.6E-08
Emergency response planning	7.3E-08	5.5E-08	5.5E-08	7.3E-08	3.6E-08	5.5E-08	1.8E-08	5.5E-08	5.5E-07	3.6E-08
Frequent worksite inspections	9.1E-05	9.1E-05	7.3E-05	9.1E-04	7.3E-05	7.3E-05	5.5E-05	7.3E-05	9.1E-05	5.5E-05
Safety and health committees	7.3E-05	5.5E-05	5.5E-05	7.3E-05	5.5E-05	5.5E-06	5.5E-05	7.3E-05	5.5E-05	5.5E-06
Safety and health orientation	5.5E-05	5.5E-05	5.5E-05	7.3E-05	5.5E-05	5.5E-06	5.5E-06	7.3E-05	5.5E-05	5.5E-07
Substance abuse programs	9.1E-05	7.3E-05	7.3E-05	7.3E-05	7.3E-05	5.5E-05	5.5E-07	7.3E-05	7.3E-05	5.5E-05
Safety manager on site	7.3E-05	7.3E-05	7.3E-05	9.1E-05	7.3E-05	7.3E-05	7.3E-05	9.1E-04	9.1E-05	5.5E-06

3.6.3. Safety Risk Mitigation Analysis

One of the chief reasons for quantifying the ability of safety program elements to reduce safety risk is to provide safety managers with guidance when selecting elements to implement on site. Table 3.12 identifies the most effective safety program elements. The values in Table 3.12 represent unitless risk scores that can be used to evaluate the relative effectiveness of the safety program elements. Because the units of severity on the 1-10 scale truly exist in a geometric sequence, it would be inappropriate to describe the product of the probability and severity reduction values with dimensions. More discussion on this topic is provided in Manuscript 4.

According to this table and the corresponding figure (Figure 3.3), the two most effective elements are upper management support (risk reduction score of 0.0144) and strategic subcontractor selection and management (risk reduction score of 0.0133). These two program elements are nearly an order of magnitude more effective than the next highest program element: employee involvement in safety and health management and planning (risk reduction score of 0.000433).

A careful analysis of Table 3.12 reveals that the safety program elements exist in four tiers of effectiveness with each tier being separated by nearly an order of magnitude. These tiers are illustrated in Figure 3.3. As one can see, the most effective safety program elements (upper management support and commitment and subcontractor selection and management) have risk reduction scores between 0.01 and 0.1. The second-tier elements, (employee involvement in safety management and planning, job hazard analyses, training and regular safety meetings, frequent worksite inspections, and a site-specific safety manager) have risk reduction scores between 0.001 and 0.01. The third-tier elements (substance abuse programs, safety and health committees, safety and health orientation, and a written safety plan) have risk reduction scores between 0.0001 and 0.001. Finally, the fourth-tier elements (record keeping and accident analyses and emergency response planning) have risk reduction scores between 0.000001 and 0.00001. This information

may be very valuable for construction safety managers who must strategically allocate limited resources to their safety program.

One should note that some of the program elements listed in Table 3.12 and Figure 3.3 may be required in some firms or by the Occupational Safety and Health Administration (OSHA). However, the expected benefits of implementation of such efforts may be evaluated using the data provided.

Table 3.12 – Risk mitigation values

Safety Program Element		Risk Reduction (unitless score)
Tier 1	Upper Mgt Support	1.44E-02
	Subcontractor selection and mgt	1.33E-02
Tier 2	Employee involvement	4.33E-03
	Job hazard analyses	3.53E-03
	Training and regular safety meetings	2.71E-03
	Frequent worksite inspections	1.58E-03
	Safety manager on site	1.53E-03
Tier 3	Substance abuse programs	6.37E-04
	Safety and health committees	5.02E-04
	Safety and health orientation	4.30E-04
	Written safety plan	3.03E-04
Tier 4	Record keeping and accident analysis	3.71E-06
	Emergency response planning	1.00E-06

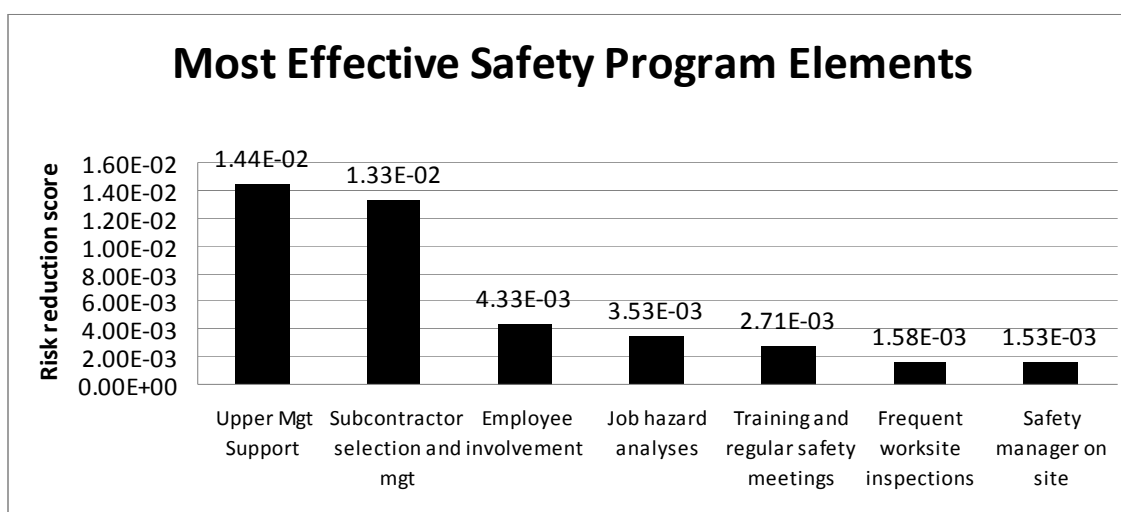

Figure 3.3 – Most Effective Safety Program Elements

In addition to the evaluation of each safety program element, one may be curious how much risk is mitigated for each of the ten safety risk classification codes as a result of the implementation of all thirteen safety program elements. Table 3.13 indicates the collective risk mitigation resulting from the implementation of all thirteen program elements. As one can see, the elements mitigate the highest portion of risk for struck-by, struck-against, caught-in and falls to lower level. Conversely, the risk mitigated for transportation accidents, exposure to harmful substances, repetitive motion, and overexertion incidents is the lowest. This information may help safety and risk managers to identify the risks that are mitigated most easily and those that are more robust. One must note that the values published in Table 3.13 do not take into account potential diminishing returns due to the simultaneous implementation of multiple elements.

Table 3.13 – Risk mitigation due to the implementation of 13 elements

Safety Risk Classification Code	Risk mitigation due to implementation of all program elements (risk reduction score)
Struck-by	0.0038
Struck-against	0.0014
Caught-in	0.0027
Fall to Lower	0.0258
Fall to Same	0.0013
Overexertion	0.0005
Repetitive Motion	0.0004
Exposure to Harmful Substances	0.0056
Transportation Accidents	0.0014
Other	0.0003

Limitations

One should note that all of the risk values obtained through the Delphi process are limited in the several ways due to the specific directions given to the Delphi panelists. More detailed discussion of limitations in this study is provided in Manuscript 4. Limitations include:

- The values represent the average for all firms in the industry regardless of size, geographic location, safety record, etc.
- The risk values represent average risk levels that would occur if no other safety programs are implemented.
- Interactions and possible diminishing returns have not been evaluated.
- The risk values represent the judgment of safety experts and do not represent empirical data.

3.7. APPLICATION

The data collected for this manuscript can be used as guidance in the construction industry by safety and health and risk managers when selecting the safety efforts to implement on construction sites. For example, when resources are limited the data can be used to formally select program elements for implementation based on their relative effectiveness. The author suggests that managers perform a cost-benefit analysis using this data to determine the most cost-effective elements to implement on site.

The goal of any safety program is to maximize the risk mitigation of the safety program while consuming the minimum level of resources. Therefore, the author suggests that using company cost data to determine the relative cost of the program elements and, using the data presented in this manuscript, perform a cost-benefit analysis thereby maximizing the use of limited resources. An example scenario of such a procedure is provided for reference below. Example cost data has been created using approximations from the experience of the author. The projected costs in Table 3.14 SHOULD NOT be used for planning purposes and are only approximations used to illustrate an example method of application.

Table 3.14 – Example effectiveness ratings

Safety Program Element	Risk Reduction Score	Projected cost	Effectiveness ratio
Subcontractor selection and mgt	1.33E-02	\$ 15,000.00	8.87E-07
Upper Mgt Support	1.44E-02	\$ 20,000.00	7.21E-07
Job hazard analyses	3.53E-03	\$ 10,000.00	3.53E-07
Written safety plan	3.03E-04	\$ 3,000.00	1.01E-07
Employee involvement	4.33E-03	\$ 60,000.00	7.22E-08
Training and regular safety meetings	2.71E-03	\$ 60,000.00	4.52E-08
Frequent worksite inspections	1.58E-03	\$ 40,000.00	3.95E-08
Safety and health committees	5.02E-04	\$ 20,000.00	2.51E-08
Safety manager on site	1.53E-03	\$ 90,000.00	1.70E-08
Substance abuse programs	6.37E-04	\$ 55,000.00	1.16E-08
Safety and health orientation	4.30E-04	\$ 50,000.00	8.59E-09
Emergency response planning	1.00E-06	\$ 5,000.00	2.00E-10
Record keeping and accident analysis	3.71E-06	\$ 25,000.00	1.48E-10

In the above table the effectiveness ratio is calculated by simply dividing the risk reduction score by the projected cost for the hypothetical project. For this example the top 5 most cost effective safety program elements are illustrated in Figure 3.4 below.

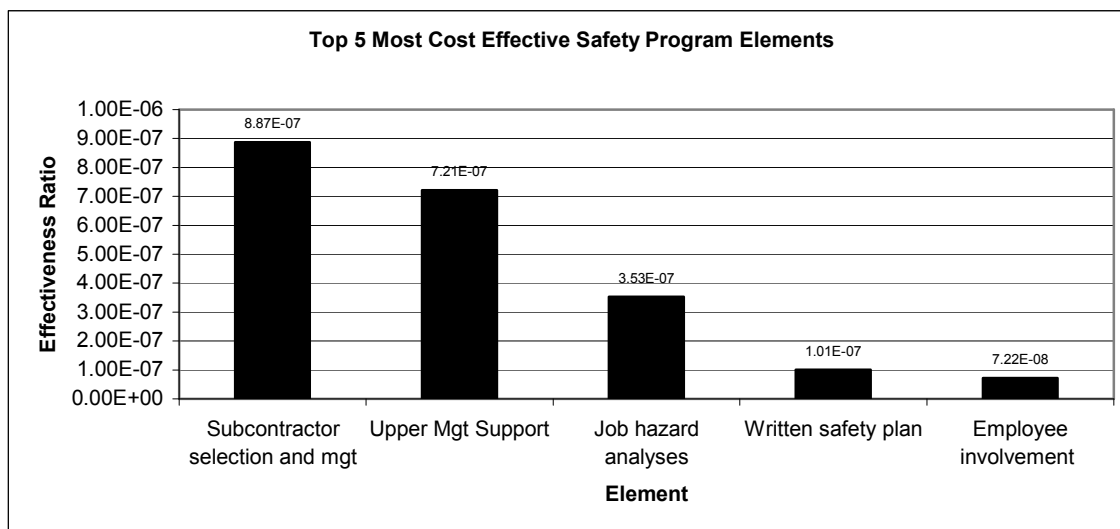

Figure 3.4 – Top 5 most cost-effective safety program elements (hypothetical example)

The data presented in this Manuscript and the method of calculating the cost effectiveness ratio can be used to strategically select the safety program that is capable of mitigating the greatest portion of the safety risk. Other applications of this risk mitigation

data are discussed in the following manuscript. When used in tandem with the safety risk demand data discussed in Manuscript 2, the safety risk capacity data can be used to evaluate the resulting risk levels once specific safety programs are implemented. Evaluating the balance between demand and capacity is the key to evaluating the resulting risk on the construction project and the overall effectiveness of the safety program.

3.8. CONCLUSIONS

The primary purpose of this manuscript was to quantify the construction safety risk mitigation associated with safety program elements. Thirteen safety program elements were identified in literature as the “essential” safety program elements. Once the essential elements were identified and defined, the Delphi process was implemented in an effort to quantify the probability and severity reduction resulting from the independent implementation of each essential program element. The Delphi process designed and discussed in Manuscript 2 was replicated for this portion of the study using the same processes and methods of minimizing judgment-based bias.

During the Delphi process described for this phase of the research, an initial group of fourteen individuals were certified as experts according to criteria defined by literature. Eleven of the fourteen experts completed the first round of surveys and ten of the original fourteen completed Rounds 2 and 3. In the second round, the experts were provided with a re-randomized survey form that included the median response from Round 1. Experts were also asked to provide reasons for responses that were two or more units from the Round 1 median. In Round 3, all remaining experts completed the forms and were asked to reconsider their ratings in light of their peer’s reasons for outlying responses. During the three rounds the expert panel closely approached consensus which was measured by the absolute median. After the third round, the absolute deviation was approximately 0.82.

The resulting data matrix from the Delphi survey was presented and converted to useable units of probability, severity, and risk. The subsequent analysis indicated that the safety program elements existed in four levels of effectiveness. Using the projected cost of implementation of each of the safety program elements allows the user to identify the most cost-effective elements.

Using the data presented in this manuscript and the cost-effectiveness calculations, one may strategically and formally select safety program elements for implementation. In other words, one can use the data and the simple projected cost calculations to design the most effective safety program given the resources available.

The following manuscript provides the reader with an overview of the efforts implemented to validate the findings introduced in the first three manuscripts, indicates how the demand and capacity data may be used to evaluate equilibrium on construction projects, and reviews the limitations of the data and proposed safety management methods.

MANUSCRIPT 4.0

**POPULATION AND VALIDATION OF A FORMAL MODEL FOR
CONSTRUCTION SAFETY AND HEALTH RISK MANAGEMENT**

Matthew Hallowell

4.1. PREFACE

The previous three manuscripts introduced and populated a formal model for safety risk management. Manuscript 1 presented a theoretical framework for a risk-based model that is structured around the concept of equilibrium. Manuscript 2 summarized a study that implemented the Delphi research method to quantify safety risks associated with the construction of concrete formwork. Manuscript 3 summarized a similar Delphi study that quantified the risk mitigation resulting from the independent implementation of essential safety program elements. Collectively, these three manuscripts provide the theoretical framework for a risk-based model and the data necessary to use this model in practice. The present manuscript merges the concepts of Demand and Capacity into a final, data-driven model that can be used to improve the effectiveness of construction safety and health risk management.

4.2. INTRODUCTION

Currently, there are numerous methods of safety risk management on construction projects. However, the construction industry lacks a formal, standardized method of evaluating safety and health risks. Perhaps even more alarming is the lack of guidance for selecting safety program elements for a particular project. Currently, the method of selecting elements is based on the “birdshot” approach. That is, safety management for a construction project is operated under the assumption that “more is better.” This approach may be adequate for large contractors that have the finances to implement the majority of

applicable safety program elements but is not effective for small firms that must strategically select a subset of applicable elements.

The National Institute of Occupational Safety and Health (NIOSH) estimates that 90 percent of construction firms employ 20 or fewer workers. Furthermore, these firms often lack a safety management system (NIOSH 2007). Typically, these types of firms operate with a very limited safety and health management budget and are forced to select a small subset of the applicable safety program elements. Current literature provides little to no guidance that aids small firms in their decision-making process.

The theoretical model introduced and described in the first manuscript provided a formal method for evaluating safety and health risks on construction sites. This activity-based risk quantification method allows a manager to quantify the cumulative risks associated with a construction process (i.e., Demand). Also, the model may be used to evaluate the relative effectiveness of essential safety program elements. When these two concepts are merged, the theoretical model can be used to evaluate resulting risk (i.e., degree of equilibrium). Ideally, this model would be used by a safety manager to identify the most effective safety program elements and the level of safety protection based on the specific activities expected on site. The next section of this introduction includes a review of the safety equilibrium model outlined in the first manuscript.

4.2.1. Review of the theoretical model

The concept of equilibrium, based upon Newton's third law, is widely known in the fields of physics and engineering. Simply put, Newton's third law states that for every action there must be an equal and opposite reaction. In structural engineering, this concept is employed when designing support systems for various loading schemes. In order to be structurally effective, a system must be designed in such a way that the capacity of the system is greater than or equal to the maximum anticipated load. In other words, the

loading capacity must meet or exceed the loading demand. This relationship is illustrated in the following design relationship for flexure in a structural member:

$$M_u \leq \Phi M_n \quad \text{where,} \quad (\text{Eq. 4.1})$$

M_u : Ultimate Moment (i.e., maximum design demand),

M_n : Design Moment (i.e., nominal moment or capacity),

Φ : Factor of Safety

When this same concept is applied to construction safety one may recognize that the safety risk demand is equal to the sum of the safety risk on a construction site. Assuming that every safety program element offers some form of safety risk mitigation, the sum of that mitigation ability is equal to the capacity of the safety system. In theory, to reach equilibrium and make the safety system stable (i.e., accident-free), the capacity of the safety program must meet or exceed the safety demand. This relationship is expressed in the following expression (Equation 4.2), modeled after Equation 1.

$$S_u \leq \Phi S_n \quad \text{where,} \quad (\text{Eq. 4.2})$$

S_u : Safety Risk Demand (i.e., the cumulative safety risk on the construction site)

S_n : Safety Capacity (i.e., the cumulative mitigation ability of the safety program)

Φ : Factor of Safety

A factor of safety is included in both equations. As with any engineered system, a factor of safety should be employed to compensate for potential errors in the quantification of demand values (e.g., loading or cumulative safety risk) or capacity (e.g., strength of the system or ability of the safety program to mitigate risk).

Once the safety risk demand has been quantified, the equilibrium equation (Equation 4.2) may be applied. Using this model allows one to evaluate the relative effectiveness of safety program elements and identify when equilibrium is achieved. The structure of the equilibrium model is illustrated in Figure 4.1.

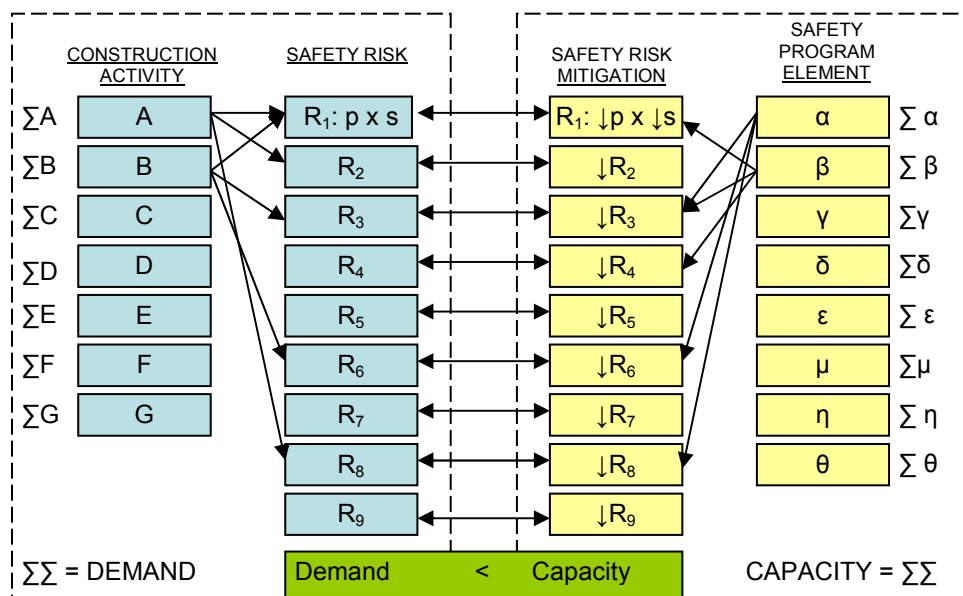

Figure 4.1 – Safety Equilibrium Model

4.2.2. Achieving equilibrium

In order to evaluate the safety risk equilibrium that exists on a construction project, the risk Demand data must be compared with the risk Capacity data. As one may recall, the expert panelists were asked to rate the probability and severity of ten risk classification codes for each activity or probability and severity reduction ratings resulting from the implementation of essential safety program elements. Both expert panels used the same 1-10 scale (see Section 2.3). Because the ratings were provided on the same scale, the ratings from the Demand panel can be merged and analyzed in tandem with the Capacity data. The next major section of this Manuscript provides a methodology for merging the Demand and Capacity data to evaluate equilibrium.

4.3. APPLICATION OF THE EQUILIBRIUM CONCEPT

4.3.1. Merging Demand and Capacity

In order to use the Demand and Capacity data to quantify the risk that exists after the implementation of given safety program elements, one must follow a specific process.

Merging the Demand and Capacity data to evaluate resulting risk (i.e., the level of equilibrium) involves the following steps:

1. Determine the activities expected
2. Use the original data (1-10 on the probability scale and 1-10 on the severity scale) to define the original risk levels
3. Convert raw probability values to appropriate units
4. Select the expected safety program elements
5. For each program element implemented, reduce the probability through direct subtraction
6. For each program element implemented, reduce the raw 1-10 severity ratings from the Demand data by the number of units indicated in the Capacity data for each safety program element implemented
7. Interpret the resulting severity values and multiply by the resulting probabilities to determine the resulting risk values for each activity
8. Sum the resulting risk values to determine the cumulative resulting risk

Evaluating the residual risk is not as simple as subtracting the scaled Capacity values from the scaled Demand values because the risk severity scale is not linear. To review, the Capacity panel was asked to define the reduction in probability and severity (on the 1-10 scale) resulting from the independent implementation of each safety program element. In other words, if the Capacity panel believed that a safety program element could reduce the severity of an injury by three units, the total amount of severity reduced would depend heavily on the original severity of the specific incidents!

When properly integrated, the equilibrium model can be used in several ways, including:

1. Predicting periods of high risk
2. Identifying high risk activities
3. Identifying the most effective safety and health efforts given specific activities
4. Evaluating resulting risk

The first three applications have been discussed previously. The following section will focus mainly on the evaluation of resulting risk.

4.3.2. Evaluating resulting risk

To illustrate the appropriate methodology for evaluating resulting risk using the data in this dissertation, an example will be provided. By following this procedure, the reader can use the data presented in this manuscript to evaluate any combination of formwork activities and safety program elements.

For this example, assume that workers expect to perform the following activities during a one-hour time period:

- Accept/load materials from a crane
- Lift/lower materials
- Transport materials or equipment without motorized assistance
- Excavation
- Form lubrication and preparation

Table 4.1 shows the Delphi panel's original probability and severity for the 10 accident classification codes and the original risk (i.e., probability x severity). The probability values and the original risk values have been interpreted using the appropriate scales. The severity values, however, have not been scaled. The product of the scaled probability and scaled severity values represent the original risk.

For this example, also assume that the following two safety program elements are implemented:

- Record keeping and accident analyses
- Emergency response planning

The original probability and severity reduction values obtained from the Delphi panel and interpreted using the appropriate scales can be found in Table 4.2. In order to apply these reduction values and evaluate resulting risk, one must first subtract the probability and severity reduction values from the original risk values. Because the Delphi panel responsible for the quantification of probability reduction was asked to indicate the average increase in number of worker-hours per incident, the probability reduction values can be subtracted directly from the original probability values without additional conversion or interpretation.

To apply the severity reduction values, however, one must reduce each severity rating by the indicated number of units from the Capacity panel. The resulting severity values (i.e., demand – capacity) must then be interpreted using the appropriate scale. The resulting probability, severity, and risk values are included in Table 4.3. All of these values in Table 4.3 have been interpreted using the appropriate scales. All negative resulting values for probability or severity have been changed to a value of 0 as negative probability and severity values would be impossible.

Table 4.1 – Original probability, severity, and risk

PROBABILITY										
Incident Type										
Struck-by	Struck-against	Caught-in	Fall to Lower	Fall to Same	Overexertion	Repetitive Motion	Exposure to Harmful Substances	Transportation Accidents	Other	
Accept/load/connect materials or forms from crane	1.8E-03	1.8E-04	1.8E-06	1.8E-05	1.8E-06	1.8E-07	1.8E-08	1.8E-06	1.8E-08	
Cut materials using circular or table saw	0.0E+00	0.0E+00	0.0E+00	0.0E+00	0.0E+00	0.0E+00	0.0E+00	0.0E+00	0.0E+00	
Inspect forms and construction planning	0.0E+00	0.0E+00	0.0E+00	0.0E+00	0.0E+00	0.0E+00	0.0E+00	0.0E+00	0.0E+00	
Lift or lower materials, form components or equipment	1.8E-03	1.8E-05	1.8E-06	1.8E-04	1.8E-03	1.8E-04	1.8E-08	1.8E-08	1.8E-08	
Transport materials and equipment without motorized assistance	1.8E-06	1.8E-06	1.8E-06	1.8E-04	1.8E-04	1.8E-05	1.8E-08	1.8E-06	0.0E+00	
Excavation	1.8E-04	1.8E-05	1.8E-04	1.8E-05	1.8E-04	1.8E-07	1.8E-07	1.8E-07	0.0E+00	
Form Lubrication and preparation	1.8E-08	1.8E-08	1.8E-05	1.8E-07	1.8E-05	1.8E-05	1.8E-02	1.8E-04	0.0E+00	
SEVERITY										
Incident Type										
Struck-by	Struck-against	Caught-in	Fall to Lower	Fall to Same	Overexertion	Repetitive Motion	Exposure to Harmful Substances	Transportation Accidents	Other	
Accept/load/connect materials or forms from crane	8	7	7	6	4	3	2	5	2	
Lift or lower materials, form components or equipment	6	5	7	6	5	5	3	6	3	
Transport materials and equipment without motorized assistance	6	6	7	6	7	5	3	5	2	
Excavation	8	8	7	6	5	5	4	6	2	
Form Lubrication and preparation	5	5	8	6	6	6	9	8	2	
RISK										
Incident Type										
Struck-by	Struck-against	Caught-in	Fall to Lower	Fall to Same	Overexertion	Repetitive Motion	Exposure to Harmful Substances	Transportation Accidents	Other	
Accept/load/connect materials or forms from crane	4.65E-01	2.33E-02	2.33E-04	1.16E-03	2.91E-05	1.45E-06	7.27E-08	5.82E-05	7.27E-08	
Lift or lower materials, form components or equipment	1.16E-01	5.82E-04	2.33E-04	1.16E-02	5.82E-02	5.82E-03	1.45E-07	1.16E-06	1.45E-07	
Transport materials and equipment without motorized assistance	1.16E-04	1.16E-04	2.33E-04	1.16E-02	2.33E-02	5.82E-04	1.45E-07	5.82E-05	0.00E+00	
Excavation	4.65E-02	4.65E-03	2.33E-03	1.16E-02	5.82E-04	5.82E-06	2.91E-06	1.16E-05	0.00E+00	
Form Lubrication and preparation	5.82E-07	5.82E-07	4.65E-03	1.16E-05	1.16E-03	1.16E-03	1.86E+01	4.65E-02	0.00E+00	

Table 4.2 – Reduction in probability and severity

	Probability Reduction									
	Struck-by	Struck-against	Caught-in	Fall to Lower	Fall to Same	Overexertion	Repetitive Motion	Exposure to Harmful Substances	Transportation Accidents	Other
Safety Program Element										
Record keeping and accident analysis	1.82E-07	1.82E-08	1.82E-07	1.82E-07	1.82E-07	1.82E-07	1.82E-07	1.82E-07	1.82E-07	1.82E-08
Emergency response planning	1.82E-08	1.82E-08	1.82E-08	1.82E-08	1.82E-08	1.82E-08	1.82E-08	1.82E-08	1.82E-07	1.82E-08
TOTAL	2.00E-07	3.64E-08	2.00E-07	2.00E-07	2.00E-07	2.00E-07	2.00E-07	2.00E-07	3.64E-07	3.64E-08
	Severity Reduction									
Safety Program Element										
Record keeping and accident analysis	3	2	3	3	2	2	2	3	2	2
Emergency response planning	4	3	3	4	2	3	1	3	3	2
TOTAL	7	5	6	7	4	5	3	6	5	4

Table 4.3 – Resulting risk values

RESULTING PROBABILITY										
Struck- by	Struck- against	Caught- in	Fall to Lower	Fall to Same	Over- exertion	Repetitive Motion	Exposure to Harmful Substances	Transportation Accidents	Other	
Accept/load/connect materials or forms from crane	1.8E-03	1.8E-04	1.6E-06	1.8E-05	1.6E-06	0.0E+00	0.0E+00	1.5E-06	0.0E+00	
Cut materials using circular or table saw	0.0E+00	0.0E+00	0.0E+00	0.0E+00	0.0E+00	0.0E+00	0.0E+00	0.0E+00	0.0E+00	
Inspect forms and construction planning	0.0E+00	0.0E+00	0.0E+00	0.0E+00	0.0E+00	0.0E+00	0.0E+00	0.0E+00	0.0E+00	
Lift or lower materials, form components or equipment	1.8E-03	1.8E-05	1.6E-06	1.8E-04	1.8E-03	1.8E-04	0.0E+00	0.0E+00	0.0E+00	
Transport materials and equipment without motorized assistance	1.6E-06	1.6E-06	1.6E-06	1.8E-04	1.8E-04	1.8E-05	0.0E+00	1.5E-06	0.0E+00	
Excavation	1.8E-04	1.8E-05	1.8E-05	1.8E-04	1.8E-05	0.0E+00	0.0E+00	0.0E+00	0.0E+00	
Form Lubrication and preparation	0.0E+00	0.0E+00	1.8E-05	0.0E+00	1.8E-05	1.8E-05	1.8E-02	1.8E-04	0.0E+00	
RESULTING SEVERITY										
Struck- by	Struck- against	Caught- in	Fall to Lower	Fall to Same	Over- exertion	Repetitive Motion	Exposure to Harmful Substances	Transportation Accidents	Other	
Accept/load/connect materials or forms from crane	1	2	1	0	2	0	0	0	0	
Lift or lower materials, form components or equipment	0	0	0	0	2	0	0	1	0	
Transport materials and equipment without motorized assistance	0	1	0	0	2	2	0	0	0	
Excavation	1	3	2	0	2	0	0	1	0	
Form Lubrication and preparation	0	0	0	1	2	1	0	3	0	
RESULTING RISK										
Struck- by	Struck- against	Caught- in	Fall to Lower	Fall to Same	Over- exertion	Repetitive Motion	Exposure to Harmful Substances	Transportation Accidents	Other	
Accept/load/connect materials or forms from crane	1.82E-03	3.64E-04	1.82E-04	0.00E+00	3.60E-05	0.00E+00	0.00E+00	0.00E+00	0.00E+00	
Lift or lower materials, form components or equipment	0.00E+00	0.00E+00	0.00E+00	3.63E-04	0.00E+00	3.63E-04	0.00E+00	0.00E+00	0.00E+00	
Transport materials and equipment without motorized assistance	0.00E+00	1.78E-06	0.00E+00	3.63E-04	3.63E-04	3.60E-05	0.00E+00	0.00E+00	0.00E+00	
Excavation	1.82E-04	5.44E-05	3.63E-04	3.63E-04	0.00E+00	0.00E+00	0.00E+00	0.00E+00	0.00E+00	
Form Lubrication and preparation	0.00E+00	0.00E+00	1.80E-05	0.00E+00	1.80E-05	5.39E-05	0.00E+00	5.44E-04	0.00E+00	

A comparison of the original risk and the resulting risk is provided in Table 4.4. As one can see from this table, the original risk level was 0.212 units of severity per worker-hour. According to the equilibrium model, the implementation of record keeping and emergency response planning resulted in a risk value of 0.00549 units of severity per worker-hour. The total risk reduced by these two elements is 0.206 units of severity per worker-hour. The dramatic reduction in risk level suggests that by implementing these two elements, the worksite is drastically safer.

Table 4.4 – Comparison of original risk and resulting risk

Incident Type	Original Risk	Resulting Risk	Difference
Struck-by	2.69E-02	2.00E-03	2.49E-02
Struck-against	1.52E-03	4.20E-04	1.10E-03
Caught-in	2.85E-03	5.45E-04	2.30E-03
Fall to Lower	3.11E-04	1.80E-05	2.93E-04
Fall to Same	3.38E-03	1.13E-03	2.26E-03
Overexertion	1.06E-02	3.81E-04	1.02E-02
Repetitive Motion	1.11E-03	4.53E-04	6.57E-04
Exposure to Harmful Substances	1.64E-01	0.00E+00	1.64E-01
Transportation Accidents	1.47E-03	5.44E-04	9.30E-04
Other	9.09E-08	0.00E+00	9.09E-08
Totals	2.12E-01	5.49E-03	2.06E-01

The following section of this dissertation focuses on the validation of the demand and capacity results. Literature related to validation of scientific studies is reviewed, methods of data collection for the validation effort are discussed, and the final results are presented.

4.4. LITERATURE REVIEW

4.4.1. Importance of validation

According to the National Institute of Occupational Safety and Health (NIOSH 2007), “Protecting construction workers from injury and disease is among the greatest challenges in occupational safety and health.” These statements provide compelling

evidence that safety and health is an issue of vital importance. Therefore, any strategies implemented to improve safety management must be driven by unbiased data that most accurately represents the actual conditions on construction sites. Using biased data to make safety and health decisions is not only poor in an academic sense, it may compromise the welfare of the workers.

One of the primary goals of this dissertation is to publish unbiased risk data that can be used to effectively manage safety and health on construction sites. During the Delphi process, the primary research method implemented in this study, many measures were taken to ensure that the results were unbiased. In fact, seven judgment-based biases that could have adversely affected the risk demand and risk capacity results were identified and controlled through various techniques such as randomization, reporting medians, and anonymous feedback. In addition to these controls, efforts were taken to validate the results by collecting secondary data.

Validation is especially important for studies that will have an impact on the overall welfare of the public. Studies that may have an impact on the health, economy, political climate, or environment are typically validated before the results are used to make influential decisions (Thorne and Geisen 2002). Since this study focuses on construction safety and health, the validation of the results is extremely important. In an academic study, the process of collecting similar data in an effort to confirm or deny values obtained through original research efforts is known as validation. As with most research, validation can be conducted in many ways.

Typically, validation research is conducted in one of three ways: retrospective analyses using archival data, alternative methods of collecting similar data, or experimental implementation of the model or strategy developed during the original research effort (Vadin and Rankin 1997). As indicated in previous sections of this dissertation, archival

data is incomplete and ineffective and experimental research is unethical. Therefore, the validation efforts for this dissertation will focus on alternative methods of data collection.

4.4.2. Risk perceptions

The chief method of data collection for the validation of the Demand data involves the collection of risk perceptions of work crews. Consequently, understanding risk perceptions is vital to this study. According to Starr (1969), risk perception is the subjective judgment that people make about the characteristics and severity of a risk event. In the last thirty years, several theories have been developed that explain why people make different estimates of the dangerousness of risks. Two major families of theory have been developed by social scientists: the Psychometric Paradigm and Cultural Theory (Thompson et al. 1990).

Daniel Kahneman and Amos Tversky conducted the original psychometric research when they performed a series of gambling experiments to see how people evaluated probabilities (Kahneman and Tversky 1973; Kahneman et al. 1982). These researchers found that people use a number of cognitive shortcuts to evaluate risks. These cognitive shortcuts in risk evaluation may lead to judgment-based biases discussed in Section 2.4.2.3. As one may recall, several control measures were taken to minimize judgment-based biases. Therefore, similar controls were implemented for the validation efforts. Techniques such as randomization, anonymity, and reporting medians were implemented to ensure minimal influence of judgment-based biases.

4.5. METHODOLOGY

The purpose of this section is to describe the various research efforts implemented to validate the results described in the first three manuscripts. In other words, the objective of this section is to validate the demand and capacity data and the concept of equilibrium.

To validate the demand data (i.e., safety risks values associated with the process of forming concrete) the values obtained in this research were compared to the risk perceptions of various crews that worked on a recent project. The specific, objective, and unbiased methodology implemented to collect this validation data is reviewed in Section 2.4.2.4.

The capacity data values (i.e., the risk mitigation values associated with the implementation of essential safety program elements) are validated using the input provided by an independent expert panel via the Delphi process. The specific research processes implemented to collect these data are summarized in Section 4.5.2.

Finally, the general concept of equilibrium, while accepted in the scientific community, is also validated as a part of this research effort. The Demand and Capacity data are used to populate the equilibrium model and data collected from recently-completed projects are compared to the resulting risk predicted by the data-driven model.

4.5.1. Demand validation

The goal of this validation effort was to determine whether the data collected during the Delphi process described in Manuscript 2 (i.e., Demand) accurately represents the risk levels that the workers experience on-site. In order to determine the viability of the Demand data, predicted risk values must be compared with actual site conditions. Many publications indicate that safety performance may be affected by numerous factors such as crew competency, time of day, weather, and project scope. Therefore, controlling for confounding factors that may influence safety performance is critical. The first mechanism implemented to control these factors was to limit the data collection and the subsequent comparisons to one well-defined case study. By collecting a high volume of data on a single project, the influence of the following factors would be minimized:

- Safety culture differences within the firm
- Quality of the safety management from one project to another

- Materials used and methods of construction implemented
- Quality of the crew
- Weather
- Geographical location
- Work environment
- Project scope

A significant volume of literature indicates that many factors influence safety performance on the site. The items listed above represent only a small portion of the factors that influence construction safety. By closely examining detailed data collected from one project, the impacting factors related to the organization, environment, political climate, and project characteristics can be minimized. Other, less controllable factors such as individual behavior, risk tolerance, and field experience are not simply controlled by limiting the validation effort to one project. In this study, no effort was made to control for the characteristics of the individual crew members. Rather, averages and medians are used to report the risk perception data collected to limit the influence of any extreme personal experiences, characteristics, or behaviors.

In order to validate the risk Demand data, the process of constructing concrete formwork is highlighted. Therefore, a project that involves a significant portion of concrete formwork construction must be selected. For one project the specific activities performed by the workers is recorded. Also, data that allows the research team to determine the safety performance or risk level was collected. For this study, the author attempted to collect both safety performance data and risk perception data. The specific research activities conducted in this study to validate the Demand results are as identified and defined as follows:

- **Identify individual, independent crews**

The first step in this research effort was to identify work crews that contain an observable number of workers. Based on the research experiences of the author, a target crew size of three to five workers is ideal for observation. For example, observing only one worker would severely limit the productivity of the study. Likewise, observing more than five individuals at any given time would be overwhelming for the observer. In addition to an adequate crew size, multiple work crews were targeted.

- **Record the activities performed by each worker during each four hour period**

During crew observations, the specific activities conducted by the workers were recorded. These activities are a vital component of the Demand portion of the equilibrium model. Since the workday is typically divided into two major work periods, each consisting of approximately four hours (e.g., 7 to 11 am → Lunch → 12 pm to 4 pm) the data was collected and summarized every four hours.

- **Record the duration of the activities performed for each worker**

In order to determine total risk, the exposure of the workers to various activities must be determined. Exposure was represented as the duration of time devoted to each activity. As one may recall, the probability values were originally represented by worker-hours per incident. Therefore, determining the number of worker-hours spent on each activity is required to calculate cumulative risk.

- **Record and incidents or near misses that occur during each four-hour period**

One obvious measure of safety performance is the incident rate for a project. Because construction incidents (fortunately) do not happen frequently enough to guarantee viewing multiple incidents, alternative methods of data collection must be considered. Therefore, to supplement the incident rate data, the risk perception of the workers was identified throughout the course of the work day.

- **Interview all of the workers observed once during each four-hour period to determine the workers' risk perceptions**

During the break times in each four hour period, the workers were interviewed to determine their risk perception for the work they are currently performing. Safety risk perceptions are used to serve as a replacement when incident data is insufficient. The safety risk perceptions were collected in such a way that the perceptions collected from the workers correspond to the demand and capacity scales developed earlier in this dissertation. Further discussion of risk perceptions is provided in the following section.

4.5.1.1. *Obtaining Risk Perceptions*

To compare the risk predictions made by the model to actual site conditions, additional measures of safety performance beyond incident rates is typically required. Incident rates alone may be inadequate because of the lack of observable incidents. Therefore, the risk perceptions of the workers and safety managers are used as a supplement. In this publication, risk perceptions refer to the opinions of the workers regarding the probability and/or frequency of various incident severity types given the conditions of the work period. By asking the workers the expected frequency of various injury severities (e.g., frequency of injuries that require minor first aid treatment) risk values may be calculated.

The plan for obtaining risk perceptions for the selected project involves interviewing workers during break periods. Workers were asked to estimate the duration of time that would exist between incidents associated with each of the severity levels. For example, workers were asked to estimate the number of hours of work that would be required (in hours, days, years, etc.) for the crew to experience a lost work time injury given the exact conditions during the work period. Workers were asked to approximate the probabilities for multiple severity levels. When appropriate, definitions of the severity levels were provided to the workers.

One worker's risk perception score is represented by the product of the probability of an incident with a given severity (i.e., frequency identified in the interview) and the scaled value of the associated severity level. The median risk perception score for the worker ultimately represent the worker's perception for the given time period. For example, if the worker believes that a first aid injury will occur once every two weeks, a lost work-time injury would occur once every two years, and a fatality would occur once every fifty years (given the crew size and project conditions for the work period), the worker's risk perception would be equal to the median of the products of probability and severity for injury severity descriptions. Scales reviewed in Section 2.4 were used for this risk perception calculation. An example of this calculation method is provided in Section 5.6.

To control for potential biases in risk perceptions the following controls were implemented:

- The average risk value rated by each worker represents the risk perception for the worker during the specific time period. This redundancy is expected to minimize the bias associated with recency,
- The median risk perception of all crew members involved with the time period will represent the risk for the crew for the given time period. This technique is expected to minimize myside, recency, neglect of probability, and dominance biases.

To aid the workers in their rating of potential probability, workers were asked to identify duration between incidents for a given severity type using recognizable time periods such as hours, days, weeks, months, and years. Rather than ask the workers how many worker-hours they would expect between injuries, the workers were asked to identify the duration between injuries given the same conditions of the work period in question (i.e., crew size, weather, project type, activities, etc.). The responses were then later converted to worker-hours. Table 4.5 indicates the conversion from recognizable worker periods to worker

hours for a crew of 10 workers. The actual conversions are made in the analysis section of this manuscript.

Table 4.5- Worker-hour equivalents for recognizable time periods (crew of 10 workers)

Recognizable time period	Worker-hours
1 hour	10 worker-hours
1 day	80 worker-hours
1 week	560 worker-hours
1 month	16,800 worker-hours
1 year	201,600 worker-hours

The activity observation form is included in Appendix L. This form includes a record of all activities conducted and the approximate duration of each activity. An example of a risk perception survey is included in Appendix J. Finally, the form used to collect incident data for each time period can be found in Appendix K.

4.5.2. Capacity validation

The second form of validation for this study involves the confirmation of the mitigation values associated with the implementation of safety program elements. Because the safety risk mitigation data is so complex and abstract, the author determined that using project data to validate the Delphi ratings would be impractical. The Capacity data was compared to the relative effectiveness ratings collected from a second, independent Delphi panel.

The Delphi panel charged with the responsibility of validating the Capacity results was asked to rate the relative effectiveness of the thirteen essential safety program elements on a 1 to 10 scale. The validation panel was not provided with any information regarding data collected during previous phases of this research. That is, the Delphi panelists charged with the responsibility of validation were not provided with Capacity data in any way.

The specific research methods associated with the Delphi process are reviewed in great detail in Section 2.4.2.4. Refer to this section for information regarding the Delphi research method, methods of minimizing judgment-based bias, and the specific design of the Delphi method for this study.

4.5.3. Equilibrium validation

The final validation effort for this research involves verifying the concept of equilibrium. While well-established in the scientific community, the author attempted to validate the application of the equilibrium to safety risk management. Because the equilibrium model requires the quantification of Demand and Capacity, the validation effort first involved the quantification of risk Demand for the construction of concrete formwork for a particular project. Following this initial step, the details of the safety efforts were obtained and the capacity of the safety program for the project can be calculated. Finally, the resulting risk (i.e., the difference between the Demand and Capacity) was correlated with the incident rate and safety perception of the safety manager on the construction site.

The risk demand values are calculated by determining the formwork construction activities and the estimated durations of the activities for the given project. The form used to collect this information from construction managers for a completed project can be found in Appendix J-M. The risk capacity are calculated by determining the safety program elements implemented on the associated construction project. The form used to determine the safety program elements implemented can be found in Appendix M. Finally, the incident rates and safety perception surveys can be found in Appendix K and J, respectively. One will note that the safety perception surveys sent to the safety managers are identical to those used to determine the risk perceptions of the workers outlined in Section 4.5.1.1. To determine the degree of validation, the difference between the demand and capacity for the particular project (i.e. resulting risk) were independently plotted against the safety risk perception and incident rate for each project.

4.6. RESULTS

This results section is divided into three sections: Demand validation, Capacity validation, and the validation of the equilibrium concept. The research methods implemented to collect data are introduced and presented in the previous section of this manuscript.

4.6.1. Demand validation

The results of the efforts to validate the risk values associated with the construction of concrete formwork identified through the research efforts described in Manuscript 2 are presented in this section. Because archival data is limited and experimental data is unethical, the focus of these results is the use of a project case study.

4.6.1.1. *Project analysis*

The following sections describe the efforts to validate the Demand data through the use of risk perceptions and project observations.

4.6.1.1.1. *Project description*

The project selected for this validation effort was chosen because it included a site layout that involved multiple, similar units simultaneously under different phases of construction. This project, a four-story apartment structure, was located in the Pacific Northwest and consisted of three distinct, but similar, wings. When observed each of these three segments of the building were at different stages. In section one the foundation was being poured, in section two the walls were being formed, and in section three an elevated (second story) floor slab was being formed. All three sections of the building, while at different stages of production, were being constructed simultaneously during the data collection for this study. The construction of the formwork for the walls and the elevated slab was the focus of this validation effort.

The workers involved in the construction of formwork were divided into two crews. The first crew was responsible for constructing the formwork for the walls and the second crew was responsible for the construction of the elevated slab. The observations for this study were divided into four units over the course of two days, each consisting of a four-hour work period. That is, observations were conducted over the course of two work-days and were divided into AM and PM for one crew and AM and PM for the second crew.

4.6.1.1.2. *Data collected*

The data for this validation effort was collected in four different, four-hour work segments. The data collection effort existed in three distinct research activities. First, the work crews were observed for each four-hour time period. During this time the worker activities were recorded. Second, the cumulative risk was calculated using the exposure values and the Demand data. The third research effort was to determine the risk perceptions of the workers after each work period.

During each work segment the specific activities, and the durations of those activities, were recorded for each worker. The duration of time spent on an activity represents the exposure factor. The data collected for this phase of the demand validation is summarized in Tables 4.6 and 4.7. As one will note these tables include the formwork construction activities and approximate number of worker-hours spent on each activity. Calculating the number of worker-hours spent on each activity during the four-hour work period involved simply summing the hours that the workers spent on each activity. Tables 4.8 and 4.9 integrate the demand data and indicate the cumulative risk for the crew as a whole.

The cumulative risk was calculated by multiplying the worker-hours spent on each activity from Tables 4.8 and 4.9 with the demand values associated with each formwork construction activity (Table 2.14 from Manuscript 2). The resulting values indicate the risk demand as predicted by the original data collected for Manuscript 2. The sum of the risk demand values for all of the activities represent the risk demand for the crew for the

four-hour work period. The demand values for the crew that were constructing the elevated slab can be found in Table 4.8 and the demand values for the crew responsible for the wall formwork is summarized in Table 4.9.

Table 4.6 – Duration of worker activities for Crew 1 (Elevated Slab)

	Elevated Slab AM		Elevated Slab PM	
	Workers	Hrs	Workers	Hrs.
Transport materials without motorized assistance	5	0.5	5	0.75
Motorized transport	0	0	0	0
Lift or lower materials, etc.	5	0.75	5	0.75
Static Lift	5	0.25	5	0.75
Crane materials	5	0.25	3	0.5
Cut materials using circular or table saw	4	0.25	0	0
Nail/Screw/Drill form components, etc.	1	0.25	0	0
Hammer w/ sledgehammer, etc.	3	0.25	3	0.25
Plumb and/or level forms	1	0.25	4	0
A/D ladder	5	0.75	5	0.25
Inspect forms and construction planning	5	1.25	5	1.25
Excavation	0	0	0	0
Form lubrication	0	0	0	0
Total wk-hrs	21		21	

Table 4.7 – Duration of worker activities for Crew 2 (Wall)

	Wall AM			Wall PM		
	Workers	Hrs.	Worker-hours	Workers	Hrs.	Worker-hours
Transport materials without motorized assistance	5	0.5	2.5	5	0.5	2.5
Motorized transport	0	0	0	0	0	0
Lift or lower materials, etc.	5	0.75	3.75	5	0.5	2.5
Static Lift	5	0.25	1.25	5	0.25	1.25
Crane materials	5	0.75	3.75	5	0.75	3.75
Cut materials using circular or table saw	0	0	0	0	0	0
Nail/Screw/Drill form components, etc.	0	0	0	0	0	0
Hammer w/ sledgehammer, etc.	5	0.25	1.25	3	0.5	1.5
Plumb and/or level forms	5	0.5	2.5	5	0.5	2.5
A/D ladder	4	0.25	1	5	0.25	1.25
Inspect forms and construction planning	5	0.5	2.5	4	1	4
Excavation	0	0	0	0	0	0
Form lubrication	4	0.5	2	4	0.5	2
Total wk-hrs			21	Total wk-hrs		21

Table 4.8 – Cumulative risk for Crew 1 (Elevated slab)

Activity	Elevated Slab AM		Elevated Slab PM	
	Worker-hours	Cumulative Risk	Worker-hours	Cumulative Risk
Transport materials without motorized assistance	2.500	0.090	3.750	0.135
Motorized transport	0.000	0.000	0.000	0.000
Lift or lower materials, etc.	3.750	0.727	3.750	0.727
Static Lift	1.250	0.034	3.750	0.103
Crane materials	1.250	0.642	1.500	0.770
Cut materials using circular or table saw	1.000	0.050	0.000	0.000
Nail/Screw/Drill form components, etc.	0.250	0.008	0.000	0.000
Hammer w/ sledgehammer, etc.	0.750	0.185	0.750	0.185
Plumb and/or level forms	0.250	0.027	0.000	0.000
A/D ladder	3.750	6.983	1.250	2.328
Inspect forms and construction planning	6.250	0.039	6.250	0.039
Excavation	0.000	0.000	0.000	0.000
Form lubrication	0.000	0.000	0.000	0.000
	Total	8.786	Total	4.288

Table 4.9 – Cumulative risk for Crew 2 (Wall)

Activity	Wall AM		Wall PM	
	Worker-hours	Cumulative Risk	Worker-hours	Cumulative Risk
Transport materials without motorized assistance	2.500	0.090	2.500	0.090
Motorized transport	0.000	0.000	0.000	0.000
Lift or lower materials, etc.	3.750	0.727	2.500	0.485
Static Lift	1.250	0.034	1.250	0.034
Crane materials	3.750	1.926	3.750	1.926
Cut materials using circular or table saw	0.000	0.000	0.000	0.000
Nail/Screw/Drill form components, etc.	0.000	0.000	0.000	0.000
Hammer w/ sledgehammer, etc.	1.250	0.309	1.500	0.371
Plumb and/or level forms	2.500	0.266	2.500	0.266
A/D ladder	1.000	1.862	1.250	2.328
Inspect forms and construction planning	2.500	0.015	4.000	0.025
Excavation	0.000	0.000	0.000	0.000
Form lubrication	2.000	37.343	2.000	37.343
	Total	42.574	Total	42.868

4.6.1.1.3. *Crew risk perceptions*

Once the Demand for a work period had been quantified, the workers were interviewed and asked to identify their perceptions of the risk on the site for the specific conditions of the four-hour work period. The risk perceptions were solicited through structured surveys in order to minimize bias. As previously indicated, the workers were asked to estimate the duration between incident severity types by asking simple questions such as, “Given the conditions of today’s worksite and the activities that the crew was performing, how long would it take to experience a lost work-time injury of any kind?” Workers were asked to estimate durations between multiple severity types. The raw data was converted into terms of incident frequency (i.e., worker-hours per incident) as previously discussed. This perception data can be found in Tables 4.10 and 4.11. Please note that the dashes (--) in these tables represent no response. Some workers felt that they were unable to define appropriate values for some severity levels.

Several measures were implemented to minimize bias. First, the order of severity values presented to each worker was randomized. In other words, the workers were asked to rate the probability of events in a randomized order of severity. Additionally, the workers were interviewed independently to minimize dominance. Lastly, the median risk perception of each worker was used to determine the risk perception of the worker for a given time period and the median perception of the crew members represented the crew’s risk perception for the work period as a whole. Using medians ensured that the effects of outliers were minimized thereby minimizing recency, primacy, and neglect of probability biases.

Table 4.10 – Risk perceptions of Crew 1 (Elevated Slab)

Severity	Crew 1 - Elevated Slab AM				Crew 1 - Elevated Slab PM			
	W1	W2	W3	W4	W1	W2	W3	W4
Near miss	560	80	--	--	--	--	--	--
Negligible	--	--	--	--	--	--	--	--
Temporary discomfort	--	--	--	--	--	--	--	--
Persistent discomfort	560	200	--	--	80	120	--	560
Temporary pain	--	--	--	--	--	--	--	--
Persistent pain	1,960	1,120	560	2,000	560	1,120	42,000	33,600
Minor first aid	--	--	--	--	--	--	--	--
Major first aid	42,000	33,600	16,800	8,000	50,400	42,000	151,200	126,000
Lost work-time	--	--	--	--	--	--	--	--
Medical case	176,400	100,800	201,600	151,200	201,600	201,600	403,200	176,400
Permanent disablement	--	--	--	--	--	--	--	--
Fatality	--	20,160,000	--	--	--	--	--	2,016,000

Table 4.11 – Risk perceptions of Crew 2 (Wall)

Severity	Crew 2 – Wall AM				Crew 2 - Wall PM			
	W5	W6	W7	W8	W5	W6	W7	W8
Near miss	360	80	--	--	360	80	--	--
Negligible	--	--	--	--	--	--	--	--
Temporary discomfort	--	--	--	--	--	--	--	--
Persistent discomfort	800	200	--	--	200	120	240	--
Temporary pain	--	--	--	--	--	--	--	--
Persistent pain	1,680	1,120	440	2,000	560	1,120	2,240	--
Minor first aid	--	--	--	--	--	--	201,600	--
Major first aid	33,600	33,600	2,520	8,000	50,400	42,000	201,600	--
Lost work-time	--	--	--	--	--	--	--	--
Medical case	151,200	100,800	151,200	151,200	201,600	201,600	403,200	--
Permanent disablement	--	--	--	--	--	--	--	--
Fatality	--	20,160,000	--	--	--	--	--	--

4.6.1.1.4. Comparison of results

The product of the scaled severity value with the median frequency (i.e., probability) estimated by the worker represents one risk value. The median risk value for each worker during each time period represents the risk perception of one worker. The median risk perception of all four crew members represents the crew's risk perception for the given work period. The collective risk perception for the crew is then correlated with the predicted risk values from Tables 4.8 and 4.9. The strength of this relationship defines the level of accuracy of the data collected in Manuscript 2 according to the risk perceptions of the workers. The resulting plot of predicted risk Demand and worker risk perception is depicted in Figure 4.2.

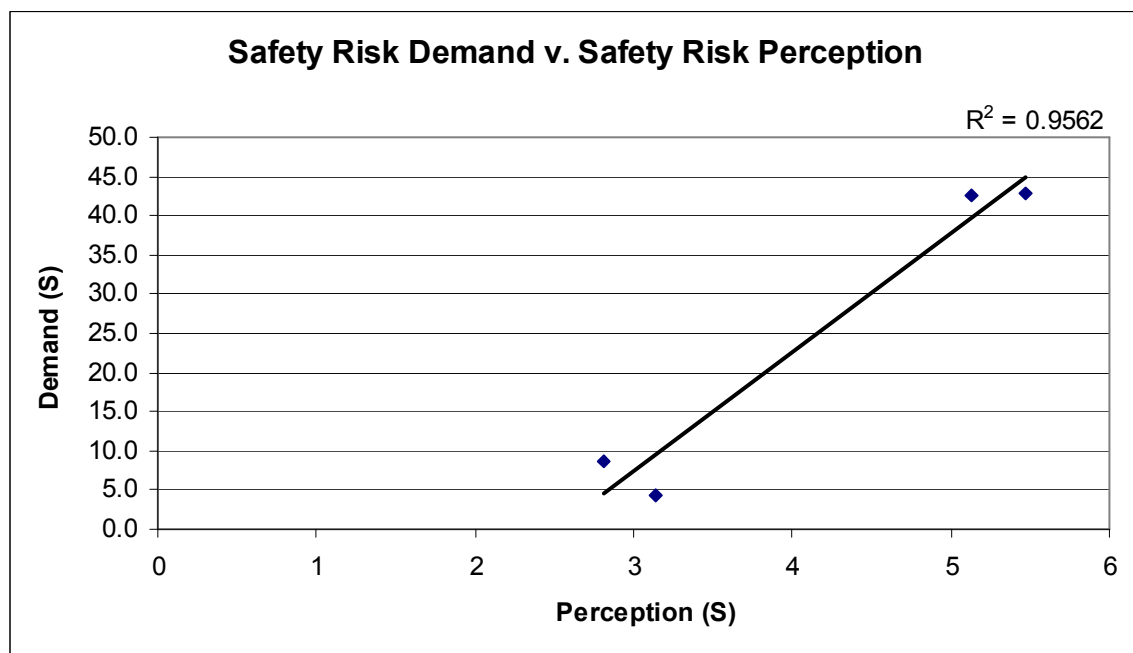

Figure 4.2 – Safety risk demand v. safety risk perception

The predicted risk for the work period is plotted against the crew member's median risk perception for the time period in the above figure. Four data points (two four-hour work periods for each crew) represent the sample size for this validation effort. As one can clearly see there is an extremely strong relationship between the two measures of risk (R-

squared value of 0.956). The r-squared value represented the degree of fit of the data by finding the square of the residuals of the data when fit to a linear regression of the two data sets. The R-squared value is recommended for such comparisons by Ramsey and Schafer (2002). The strength of fit leads the author to believe that the Demand data is indeed an accurate representation of the actual conditions on site. As an interesting aside, the strength of this correlation also indicated that these crew members are well-aware of the risk climate on site.

4.6.2. Capacity validation

The second major validation effort involved the confirmation of the risk mitigation values associated with the implementation of essential safety program elements (i.e., Capacity). Because the concept of safety risk capacity is extremely complex and likely to be influenced by many confounding factors such as weather, time of day, quality of the work crew, quality of management, etc., the author determined that project data would be inappropriate for validation. Instead, the data was validated using an independent Delphi panel. Using the same Delphi process outlined in Section 2.4.2.4, the expert panelists were asked to rate the relative effectiveness of the essential safety program elements on a 1-10 scale where 1 represents a completely ineffective element and a 10 represents an extraordinarily effective element.

4.6.2.1. Delphi

4.6.2.1.1. *Introductory Survey Results*

Individuals who currently participate on construction safety or risk management-related committees such as the American Society of Civil Engineers' Construction Site Safety Committee, have published books or journal articles on the topic of construction safety or risk management, or have participated in Delphi studies on the topic in the past were contacted and asked to participate. In total, 22 potential experts were identified.

Potential experts were e-mailed the details of the study including a brief description of the potential commitment and purpose of the study. Potential experts were also asked to complete a brief introductory survey. The primary purpose of the introductory survey was to confirm individuals as experts according to the guidelines in literature (summarized in Section 2.4.2.4.1).

Of the 22 individuals contacted, 18 agreed to participate resulting in a participation rate of 81 percent. Of the 18 individuals that agreed to participate, 17 were certified as experts in the field of construction safety and risk management. In order to be certified as an expert, each individual was required to meet at least four requirements listed in Section 2.4.2.4.1.

The demographics of the Delphi panel are summarized in Table 4.12. Panelist names have been removed to maintain anonymity.

Table 4.12 – Delphi demand panel expert characteristics

ID	State	Terminal Degree	Academic Position	Peer-reviewed Journals	Book or Book chapters	Years Industry Exp.	Licensure
V1	PA	BS	None	3	0	18	None
V2	AL	MS	None	44	0	30	CSP
V3	TX	None	None	0	0	18	Other
V4	TX	Assoc.	None	2	0	20	CSP
V5	TX	Assoc.	None	13	0	33	Other
V6	MI	BS	None	0	0	31	None
V7	AL	None	None	0	0	20	Other
V8	GA	BS	None	4	0	20	Other
V9	MI	MS	None	1	0	2	None
V10	PA	Assoc.	None	3	0	19	CSP
V11	MI	MS	Lecturer	29	1	20	CSP
V12	TX	MS	Lecturer	32	3	27	CSP
V13	MD	PhD	Lecturer	106	4	25	Other
V14	ID	MS	None	0	1	34	PE, CSP
V15	PA	PhD	Assoc. Professor	23	3	13	PE
V16	OR	PhD	Lecturer	38	1	0	None
V17	OR	PhD	Asst. Professor	7	0	1	None

As one can see from Table 4.12, the participants represent ten different states and every major geographical region of the United States. The most important aspect of Table 4.12 is the cumulative experience of the panel because the results of this study represent the consensus of these individuals. The collective qualifications of this Delphi panel are as follows:

- A large range of geographical regions are represented
- Three individuals possess a Ph.D., four possess a M.S., and two possess a B.S. as their terminal degree in a related field of study
- One individual is employed at the associate professor rank and one is employed at the assistant professor rank at an accredited academic institution
- The panel has produced a total of 305 peer-reviewed publications on the topic of construction safety and health or risk management
- The panel has produced 13 books or book chapters on the topic of construction safety and health or risk management
- The panel has over 331 years of field experience in the construction industry
- The panelists have obtained six C.S.P. licenses and two P.E. licenses.

Once certified as experts according to literature, the Delphi process continued with the transmission of the first round of surveys. An overview of the specific survey process is included in the following sections.

4.6.2.1.2. Delphi Results

Fifteen of the original seventeen panelists completed the Round 1 survey resulting in a response rate of 88 percent. Some salient aspects of the Round 1 Demand survey are as follows:

- The order of the safety program elements presented on the form was organized randomly for each panelist's custom form using the random number generator in MS Excel®. For each panelist the elements were assigned a random number. The

random numbers were ranked from highest to lowest and the order of the ranks determined the order to the activities on the survey form.

- The definitions associated with each safety program element was provided to the expert panel
- The panelists were asked to identify the most effective elements given the formwork activities outlined in Section 2.5.1.2.2.
- The median values represented the group opinion for each round and the level of consensus was measured by the absolute deviation as in the previous Delphi studies.

The results of the first round of surveys indicated that, like in the Capacity data, the safety program elements could be classified in multiple tiers of effectiveness. The results of all three rounds of Delphi process are summarized in Table 4.13. As one can clearly see, the most effective program elements were upper management support, project specific training and safety meetings, safety and health orientation and training, and job hazard analyses.

One of the goals of this validation effort is to achieve consensus among the expert panelists. The raw results of Round 1 include the average deviation from the median for each rating. As one can see from the summary, there is some deviation in the results. The absolute deviation was 1.41 units on the 1-10 scale. In other words, the absolute deviation from the median for all ratings is 1.41 units. Since group consensus of the experts is vital to the quality and precision of the results, Rounds 2 and 3 focused on reducing the variation in the expert responses and obtaining the true probability and severity values.

The absolute deviation from the median was 1.23 units and 1.02 units for rounds two and three, respectively. Therefore, after Round three the targeted consensus of approximately one unit was achieved. All expert panelists who completed the first round of surveys also completed Rounds two and three, resulting in a final response rate of 73 percent.

The median effectiveness ratings were identical for Rounds one and two. In Round three, four of the ratings changed by one half of a unit each. These changes are highlighted in Table 4.13 below. The results from Round three represent the final results for this phase of the study. These values were then compared with the safety risk capacity values in the next section of this manuscript.

Table 4.13 - Results of the Delphi process (all rounds)

Safety Program Element	Effectiveness Rating (1-10)		
	Round 1	Round 2	Round 3
Upper Management Support	10	10	10
Project-Specific Training/Meetings	9	9	9.5
S&H Orientation/Training	9	9	9
Job Hazard Analyses (JHA)	9	9	8.5
Frequent Worksite Inspections	8	8	8
Substance Abuse Programs	8	8	8
Subcontractor Selection and Mgt	8	8	8
Written Safety and Health Plan	8	8	8
Employee Involvement and Evaluation	8	8	8
Safety Manager on Site	7	7	7
Emergency Response Planning	6	6	5.5
Record Keeping/Analyses	5	5	5
Safety and Health Committees	5	5	5.5

4.6.2.2. Comparison of results

The purpose of the Delphi process described above was to determine the relative effectiveness of the safety program elements in an effort to validate the capacity values obtained via the Delphi process described in Manuscript 2. Table 4.14 compares the results from the third round of the validation process with the risk capacity values. The capacity values have been multiplied by a factor of 10,000 in order to make the numbers easier to compare visually. The data indicates that there is a reasonable degree of validation with three major exceptions. These three exceptions are highlighted in Section 4.6.2.1.2. The safety and health orientation and training, subcontractor selection and management, and written safety and health plans are in conflict with the values from the capacity ratings from the capacity Delphi process.

While there are three of thirteen elements in conflict, the remainder of the validation data confirms the effectiveness values from the Delphi process. In fact, both independent data collection methodologies resulted in three tiers of effectiveness. The first tier (i.e., most effective) program elements are upper management support, project-specific training and safety meetings, job hazard analyses, and employee involvement and planning. These top-tier elements are represented by ratings of 8 or above for the validation rating **and** ratings of 0.0040 (S/w) or over from the Delphi Capacity data. The second tier elements, worksite inspections, substance abuse programs, site-specific safety manager, and safety and health committees, have both a validation rating of 5.5 or over and a capacity rating of > 0.0001 (S/w). Finally, the third-tier elements, emergency response planning and record keeping and analysis, have a validation rating of ≥ 5.5 from the validation and a capacity rating of < 0.0001 (S/w).

Table 4.14 – Comparison of validation results (conflicting elements omitted)

Safety Program Element	Validation Rating	Capacity X 10,000
Upper Management Support	10	144.14545
Project-Specific Training/Meetings	9.5	27.14545
S&H Orientation/Training	9	4.29636
Job Hazard Analyses (JHA)	8.5	35.27273
Subcontractor Selection and Mgt	8	133.07273
Employee Involvement and Evaluation	8	43.34545
Frequent Worksite Inspections	8	15.81818
Substance Abuse Programs	8	6.36909
Written Safety and Health Plan	8	3.02909
Safety Manager on Site	7	15.32727
Safety and Health Committees	5.5	5.01818
Emergency Response Planning	5.5	0.01000
Record Keeping/Analyses	5	0.03709

Table 4.15 – Comparison of Capacity values and validation results

Tiers	Safety Program Element	Validation Rating	Capacity	Capacity (x 10,000)
1	Upper Management Support	10	0.01441	144.15
	Project-Specific Training	9.5	0.00271	27.15
	Job Hazard Analyses (JHA)	8.5	0.00353	35.27
	Employee Involvement	8	0.00433	43.35
2	Frequent Worksite Inspections	8	0.00158	15.82
	Substance Abuse Programs	8	0.00064	6.37
	Safety Manager on Site	7	0.00153	15.33
	Safety and Health Committees	5.5	0.00050	5.02
3	Emergency Response Planning	5.5	0.00000	0.01
	Record Keeping/Analyses	5	0.00000	0.04

This level of validation may be described as moderately-strong because of the slight overlap in tiers that can be observed from Table 4.15 and the three elements that are in conflict. This overlap and conflict may exist because of the following factors:

- The validation panel may have considered interactions among the safety program elements
- The two panels have different levels of qualification (i.e., the original Delphi panel was more academic and the validation panel was more industry-based)
- The validation panel may not think in terms of risk (probability x severity)

The final validation effort is described in the subsequent section of this manuscript.

4.6.3. Equilibrium validation

In an effort to validate the equilibrium concept four projects were selected as case studies. Safety managers on each of the projects were asked to complete a series of surveys that solicited information including the number of worker-hours spent on each activity, safety program elements, reports of any incidents, and a safety perception survey. The results of this effort are described below.

4.6.3.1. *Project demographics*

Two of the selected projects were being constructed in Washington State, one project in Oregon, and one in Pennsylvania. The three projects ranged in size from approximately 11 million dollars to 30 million dollars in scope. Formwork construction was complete on all but one project and all projects were more than fifty percent complete. All were building construction projects.

4.6.3.2. *Demand data*

In order to quantify the safety risk demand associated with each project, the participating safety managers were asked to identify the formwork construction activities performed and approximate number of worker-hours spent on each activity. These exposure values (i.e., worker-hours) were multiplied by the risk Demand values from Manuscript 2. The number of worker-hours per activity (i.e., exposure per activity) is defined in Table 4.16. The resulting risk Demand values for each activity on each project are summarized in Table 4.17.

Table 4.16 – Worker-hours per activity

Activity	Worker-hours per activity			
	Project 1	Project 2	Project 3	Project 4
A/D ladder	0		0	0
Static Lift	1000	30	60	480
Nail/Screw/Drill form components or other materials	1000	40	80	640
Motorized transport	250	30	60	480
Crane materials	0	40	80	600
Cut materials using circular or table saw	1000	20	40	300
Inspect forms and construction planning	250		0	0
Lift or lower materials, etc.	250	30	60	480
Transport materials without motorized assistance	250	80	160	1280
Hammer w/ sledgehammer, etc.	250	40	80	640
Plumb and/or level forms	250	40	80	640
Excavation	0	0	0	0
Form lubrication	500	0	0	0

Table 4.17 – Resulting risk Demand

Activity	Demand	Resulting Risk Demand			
		Project 1	Project 2	Project 3	Project 4
A/D ladder	1.86	0.00	0.00	0.00	0.00
Static Lift	0.03	27.58	0.83	1.65	13.24
Nail/Screw/Drill form components or other materials	0.03	32.35	1.29	2.59	20.70
Motorized transport	0.48	118.78	14.25	28.51	228.06
Crane materials	0.51	0.00	20.54	41.08	308.09
Cut materials using circular or table saw	0.05	50.18	1.00	2.01	15.06
Inspect forms and construction planning	0.01	1.55	0.00	0.00	0.00
Lift or lower materials, etc.	0.19	48.49	5.82	11.64	93.11
Transport materials without motorized assistance	0.04	9.03	2.89	5.78	46.25
Hammer w/ sledgehammer, etc.	0.25	61.82	9.89	19.78	158.26
Plumb and/or level forms	0.11	26.62	4.26	8.52	68.14
Excavation	0.11	0.00	0.00	0.00	0.00
Form lubrication	18.67	9335.86	0.00	0.00	0.00
Total		9712.27	60.78	121.56	950.91

4.6.3.3. *Capacity data*

The second phase of the equilibrium validation involved the application of capacity for the given project. The first step in this analysis involved determining the safety program elements implemented for each project. Table 4.18 summarizes the implementation of the various program elements.

As indicated earlier in this manuscript, the reduction in severity relies on initial value of demand. When the capacity data was merged with the demand data as suggested earlier it was apparent that the resulting risk was zero. These alarming results lead the researcher to investigate further. In short, the author believes that the Capacity data presented in this manuscript may not incorporate interactions among safety program elements or diminishing returns of the safety program elements. Therefore, further research to evaluate these diminishing returns is warranted. A detailed discussion of interactions and diminishing returns is provided in the conclusions of this manuscript and in the concluding remarks for this dissertation.

4.6.3.4. *Incident rates*

The safety managers interviewed and surveyed for this study were asked to identify and describe any accidents on the worksite. No injuries were reported for any of the injury severity types. That is, all projects surveyed for this study were injury-free for the construction of concrete formwork.

4.6.3.5. *Perceptions*

Due to the lack of incidents reported on the four projects, risk perceptions were solicited from the safety managers. Using the suggested process to obtain risk perceptions from the work crew, the risk perceptions for these four projects were obtained. The safety managers were asked to identify the number of worker hours per incident severity type that they would expect given the exact conditions of the formwork construction on the case projects. These values are presented in Table 4.19.

Table 4.18 – Risk perceptions

Severity	Risk Perception (number of w-h per incident)			
	Project 1	Project 2	Project 3	Project 4
Near miss	--	100	1680	220
Negligible	5000	225	3360	440
Temporary discomfort	5000	500	50400	880
Persistent discomfort	5000	15000	100800	880
Temporary pain	5000	30000	201600	880
Persistent pain	10000	60000	403200	1310
Minor first aid	10000	120000	806400	1310
Major first aid	25000	240000	1612800	19430
Lost work-time	50000	480000	3225600	19430
Medical case	100000	960000	6451200	138600
Permanent disablement	200000	1920000	12902400	277200
Fatality	--	3840000	25804800	20160000

In order to calculate the expected risk the incident frequency (worker-hours per incident) were inverted to become (incidents per worker-hour) and were multiplied by the associated scaled severity rating. The adjusted severity scale presented in Manuscript 2 was used to interpret the severity ratings. These resulting risk values can be found in Table 4.17.

Table 4.19 – Risk perceptions

Severity	Risk Perception (S*w-h)			
	Project 1	Project 2	Project 3	Project 4
Near miss	0.00E+00	0.00E+00	0.00E+00	0.00E+00
Negligible	2.00E-04	4.44E-03	2.98E-04	2.27E-03
Temporary discomfort	4.00E-04	4.00E-03	3.97E-05	2.27E-03
Persistent discomfort	8.00E-04	2.67E-04	3.97E-05	4.55E-03
Temporary pain	1.60E-03	2.67E-04	3.97E-05	9.09E-03
Persistent pain	1.60E-03	2.67E-04	3.97E-05	1.22E-02
Minor first aid	3.20E-03	2.67E-04	3.97E-05	2.44E-02
Major first aid	2.56E-03	2.67E-04	3.97E-05	3.29E-03
Lost work-time	2.56E-03	2.67E-04	3.97E-05	6.59E-03
Medical case	2.56E-03	2.67E-04	3.97E-05	1.85E-03
Permanent disablement	5.12E-03	5.33E-04	7.94E-05	3.69E-03
Fatality	0.00E+00	6.83E-03	1.02E-03	1.30E-03
Total	1.60E-03	2.67E-04	3.97E-05	3.49E-03

4.6.3.6. *Comparison*

The final step in the validation of the equilibrium concept was to determine if there was a correlation between the expected resulting risk and the safety performance on the work site. The safety performance on the worksite was measured both by incident rates and the safety risk perceptions of the safety managers. The method of calculating resulting risk was previously described.

Comparisons of this data could not be made for several reasons. First, due to the number of safety program elements implemented on the worksite, the resulting risk for the construction of concrete formwork, according to the equilibrium model, was reduced to zero for all projects. Second, the incident rate for formwork construction was also zero for all projects. While risk perceptions were obtained, correlations with these values were not possible.

4.7. CONCLUSIONS

The purpose of this manuscript was two-fold: to provide a method of integrating the Demand and Capacity data from previous manuscripts using the equilibrium concept and to validate the Demand and Capacity data described in previous manuscripts. First, a proposed methodology for integrating the Demand and Capacity data was provided. This method involves the quantification of Demand based on the expected activities. The probabilities and severities of these risks may be reduced by implementing safety program elements. In order to evaluate the resulting risk, the scaled probability values may be subtracted on the interpreted scale. The severity values, however, must be interpreted on the original scale because the adjusted scale is non-linear. In other words, the severity reduction must be performed on the original 1-10 scale. The resulting raw values can be interpreted using the adjusted severity scale and multiplied by the resulting probability to determine resulting risk. Once this methodology was created it was necessary to validate all results before implementing the populated model in practice.

Using detailed data collected from a case study project in Washington State, risk perceptions were correlated with expected safety risk demand. The data provided an extremely strong correlation (R-value = 0.96) indicating that the Demand data collected in earlier research efforts was, indeed, representative of actual field conditions. Interestingly, this strong correlation also suggests that the workers were well-aware of the risk climate for the work-period.

Several measures were taken to ensure minimal bias an influence of confounding factors. First, all crew member were interviewed and the median values represented the crew's risk perception for the work period. Second, all workers were asked to rate the expected probability for multiple severity levels to avoid biases that result from neglect of probability or recency. Finally, the order of questioning was randomized for each worker.

The second validation effort for this project involved confirming the risk mitigation values associated with the implementation of the essential safety program elements. This research process involved forming an independent Delphi panel that was asked to rate the relative effectiveness of the safety program elements. The Delphi panels reached consensus (absolute deviation of approximately 1) over the course of three rounds. The results of this process indicated that effectiveness of the program elements was modeled well by the Capacity data with three exceptions: safety and health orientation and training, subcontractor selection and management, and written safety and health plans. The relative effectiveness of these elements conflicted with the values obtained via the original Delphi panel that was asked to evaluate risks one-by-one. This indicates that the conflict may exist because the experts in the validation panel did not consider the effectiveness of the elements on a risk-by-risk basis, or the potential for interactions or diminishing returns of the safety program elements.

Finally, the author attempted to validate the concept of equilibrium. Unfortunately, the findings were such that the resulting risk for each project, according to the data presented

in this research, was zero. Furthermore, all formwork construction processes for these four projects were injury –free. The fact that the formwork processes were injury-free and the equilibrium model predicted zero resulting risk provides moderate evidence that the model is, indeed effective. However, the author believes that reducing risk on a construction site to zero is not possible because, according to risk management theory, it is impossible to reduce probability or severity to zero without avoiding or transferring the risk.

4.8. DISCUSSIONS

During the process of merging the demand and capacity data the author determined that the safety efforts required to reduce the resulting risk to zero were minimal. In fact, according to the capacity data, it is possible to reduce the risk of forming concrete to zero by implementing just a few safety program elements. Unfortunately this is contradictory to what the author has observed in practice. In fact, many firms implement all safety program elements analyzed in this study and continue to have accidents on their sites.

The author believes that the data presented in this dissertation is, indeed, accurate. However, since the effectiveness of the safety program elements was rated by the capacity panel independently, factors such as diminishing returns and interactions among safety program elements were not accounted for. Furthermore, the risk mitigation for specific risk levels were not identified as a part of the risk mitigation quantifications. In other words, the author cannot determine whether the effectiveness of an element is constant throughout the spectrum of injury severity levels.

The author cautions the reader when implementing the current model in practice as the resulting risk may be misleading. The reader is specifically cautioned when merging the two data sets to determine resulting risk as the results may be misleading. Further research is necessary to determine whether there is any interactions among safety program elements (e.g., one element may be less effective once another element has been

implemented) or diminishing returns (e.g., once several elements have been implemented, a given element may no longer be as effective as it would have been if it were the only element implemented). Further discussion of this phenomenon and suggested future research is provided in the following conclusions and discussions section of this dissertation.

CONCLUSIONS, LIMITATIONS, AND RECOMMENDATIONS

Matthew R. Hallowell

5.1. INTRODUCTION

The purpose of the conclusions section is two fold: to summarize the findings of this dissertation and to indicate whether the original objectives were achieved. Also included is a discussion of limitations and suggestions for future research. Because this dissertation summarizes multiple, independent research efforts each aimed at achieving one or more of the six primary objectives, this summary of results will be organized by objective.

To recall, the overall purpose of this research was to introduce, populate, and validate a formal model that can be used by safety managers to select the most effective safety program elements based upon the activities expected for a construction process. This overarching research objective was achieved through the collective research efforts implemented for this study.

5.2. CONCLUSIONS

All of the major and minor objectives of this dissertation were achieved. A theoretical model was created using risk management theory, the specific safety risks associated with each worker activity required to perform a common, high-risk construction process were quantified, the risk mitigation resulting from the implementation of selected safety program elements was quantified, the data was merged to create a risk-based model for construction safety risk management, and the data was validated using alternative research techniques. Additionally, the minor objectives listed in the dissertation introduction were also achieved. As indicated in the introduction, each research objective

may also be stated in terms of a research question. To review, the research questions for this dissertation are as follows:

1. What are the current methods of construction safety risk management?
2. Can a theoretical model for construction safety risk management be created using current risk management theory?
3. What are the risk values associated with the process of constructing concrete formwork?
4. Can probability and severity scales be created that encompass all potential probability and severity levels?
5. What is the risk mitigation that results from the independent implementation of safety program elements?
6. Can the risk demand and risk capacity values be combined in the manner suggested by the theoretical equilibrium model previously developed?
7. Can the results of this dissertation be validated using alternate research techniques?

The methods implemented and results found when attempting to answer the above research questions are summarized below.

5.2.1. Can a theoretical model for construction safety risk management be created using current risk management theory?

The first objective of this research was to create a theoretical model that can be used by safety managers to evaluate and reduce safety and health risks on construction projects. The corresponding research effort involved reviewing existing literature to create the risk-based model. Using literature from the fields of risk management, safety and health, social psychology, and decision analysis, the theoretical framework for a risk-based model for construction safety and health management was established. In practice, this

theoretical model can be used to evaluate safety and health risk given specific activities and safety efforts.

The theoretical model developed in this dissertation is based upon Newton's third law that claims, "For every action there must be an equal and opposite reaction." The author contends that the concept of equilibrium can be applied to safety and health management. According to the structure of the model, construction sites can be risk-free if the risk mitigation resulting from the implementation of safety program elements equals or exceeds the total risk associated with a process.

The concept of equilibrium, based upon Newton's third law, is widely known in the fields of physics and engineering. In structural engineering, this concept is employed when designing support systems for various loading schemes. In this research, the concept of equilibrium was applied to construction safety and health risk. It is assumed that every safety program element offers some form of safety risk mitigation and the sum of all risk mitigation defines the capacity of the safety system. In theory, to reach equilibrium and make the safety system stable (i.e. accident-free), the capacity of the safety program must meet or exceed the safety demand.

Safety risk equilibrium is described by the following expression:

$$S_u \leq \Phi S_n \quad \text{where,} \quad (\text{Eq. 5.1})$$

S_u : Safety Risk Demand (i.e. the cumulative safety risk on the construction site)

S_n : Safety Capacity (i.e. the cumulative mitigation ability of the safety program)

Φ : Factor of Safety (utility)

5.2.1.1. *Demand*

Creating a method for quantifying safety risk for a particular process is not a simple task. Fortunately, literature provides significant guidance. By following a series of well-defined steps a safety manager can define the total risk demand for a particular construction process. The total risk demand, S_u , for a particular process may be calculated by summing the total risk values (probability x severity) for all of the activities. This method is illustrated in Manuscript 2 using concrete formwork as an example.

5.2.1.2. *Capacity*

The capacity of a safety program can be quantified in a similar method as the risk Demand. Rather than calculate the risk value, however, one must calculate the risk mitigation when defining capacity. In a structural system, this process involves calculating the maximum load a structure may support. Similarly, in a safety system this process involves quantifying the total risk mitigation ability of the safety program. When quantifying capacity there are two components to consider: reduction in probability and reduction in severity. The total risk capacity, S_n , for a particular safety program may be calculated by summing the total risk mitigation values of all of the safety program elements. An attempt to quantify the mitigation resulting from a safety program is unprecedented in construction safety and health research.

5.2.2. **Application of the equilibrium concept to safety risk management**

Once the safety risk demand has been quantified, the equilibrium equation may be applied. The equilibrium model illustrated in Figure 5.1 can be used to identify when equilibrium between safety risk demand and the capacity of the safety program has been achieved.

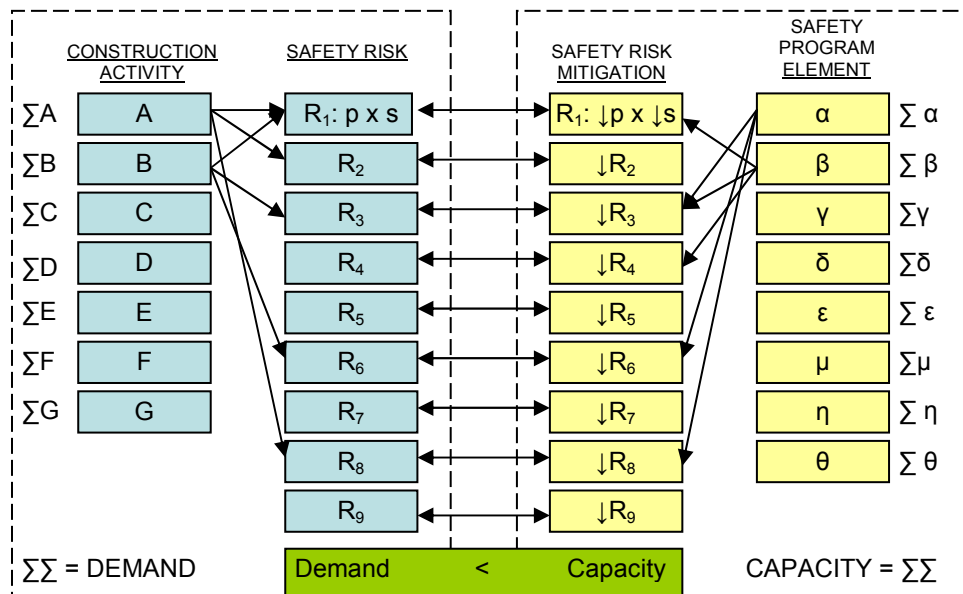

Figure 5.1 – Safety equilibrium model

5.2.3. What are the risk values associated with the process of constructing concrete formwork?

The second major research objective was to quantify the safety risks associated with a construction process. The research summarized in Manuscript 2 highlighted the construction of concrete formwork because literature and OSHA statistics indicate that the process involves a high rate of severe construction accidents. The process was also selected because it is part of nearly every construction project. In order to determine the safety risk demand of the process of constructing formwork, the specific construction activities and the potential safety risks were to be identified and described. Using a total of 256 worker-hours of field observation on 3 projects, a preliminary list of worker-activities associated with formwork construction and corresponding descriptions was created. This preliminary list was reviewed, augmented, and validated by a group of eight individuals with an average of approximately 20 years of experience resulting in a final list of thirteen distinct and well-defined activities. The potential construction safety risks were classified in ten different codes by aggregating the codes developed by three major data sources.

Once the activities and potential risks were defined, the Delphi process was implemented in an effort to quantify the probability and severity components associated with each activity for each safety risk. The Delphi research method was specifically designed for this study using guidance from literature. Additionally, forms of judgment-based bias were identified from social psychology literature and techniques such as randomization, feedback, and anonymity were implemented to minimize these biases.

During the Delphi process, an initial group of fifteen individuals were certified as experts according to criteria defined by literature. All fifteen experts completed the first round of surveys and thirteen of fifteen experts completed Rounds 2 and 3. During the three rounds the expert panel closely approached consensus which was measured by the absolute deviation. After the third round, the absolute deviation was less than 0.5 units on a 1 to 10 scale. In total, the expert panel provided over 10,000 ratings during the three rounds.

The resulting data matrix of 130 probability and 130 severity ratings from the Delphi survey was presented and converted to useable units of probability, severity, and risk. The subsequent analysis indicated that the highest risk activities included the application of form lubrication (18.67 S/w), ascending and descending ladders (1.86 S/w), and accepting materials from a crane (0.513 S/w). Considering all formwork activities, the highest safety risks were exposure to harmful substances (18.62 S/w), falls to lower level (1.88 S/w), and struck-by incidents (0.96 S/w).

5.2.4. What is the risk mitigation resulting from the independent implementation of safety program elements?

The third research objective was to quantify the risk mitigation associated with the implementation of selected safety program elements. For the research, the thirteen safety program elements were selected because they are described as “essential” by literature. Once the essential elements were identified and defined, the Delphi process was

implemented in an effort to quantify the probability and severity reduction resulting from the independent implementation of each essential program element.

Initially, a group of fourteen individuals was certified as experts according to criteria defined by literature. Eleven of the fourteen experts completed the first round of surveys and ten of the original fourteen completed Rounds 2 and 3. During the three rounds the expert panel closely approached consensus which was measured by the absolute deviation. After the third round, the absolute deviation was approximately 0.82.

The resulting data matrices from the Delphi survey (i.e., 130 probability reduction values and 130 severity reduction values on a 1-10 scale) was presented and converted to useable units of probability, severity, and risk. The subsequent analysis indicated that the safety program elements existed in four levels of effectiveness.

The first-tier safety program elements (upper management support and commitment and subcontractor selection and management) have risk reduction values between 0.01 and 0.1. The second-tier elements, (employee involvement in safety management and planning, job hazard analyses, training and regular safety meetings, frequent worksite inspections, and a site-specific safety manager) have risk reduction values between 0.001 and 0.01. The third-tier elements (substance abuse programs, safety and health committees, safety and health orientation, and a written safety plan) have risk reduction values between 0.0001 and 0.001. Finally, the fourth-tier elements (record keeping and accident analyses and emergency response planning) have values between 0.000001 and 0.000001. The ratings of relative effectiveness are unitless. These values remain unitless until incorporated in the final equilibrium model for the reasons discussed in Manuscript 3.

5.2.5. Can the risk demand and risk capacity values be combined in the manner suggested by the theoretical equilibrium model previously developed?

The fourth objective was to use the demand and capacity data to populate the theoretical model to create a data-driven model that can be used by safety managers to evaluate safety risks for a construction process. The fourth manuscript describes a specific methodology for integrating the demand and capacity data. The method developed involves the quantification of demand based on the expected activities. In order to evaluate resulting risk, the capacity values are subtracted from the demand values. However, due to the scales used in this study, the probability values and severity values must be applied independently.

The probability reduction values may be subtracted directly using the values interpreted by the appropriate probability scales. The severity values, however, must be interpreted on the original scale because the adjusted scale used to interpret the true severity units is non-linear. In other words, the severity reduction must be performed on the original 1-10 scale. The resulting raw values can then be interpreted using the adjusted severity scale and multiplied by the resulting probability to determine resulting risk.

The specific process required to evaluate resulting risk and equilibrium using the data provided in this dissertation was provided. For the example, the following activities were assumed:

- Accept/load materials from a crane
- Lift/lower materials
- Transport materials or equipment without motorized assistance
- Excavation
- Form lubrication and preparation

Likewise, the following two safety program elements were implemented:

- Emergency response planning
- Recordkeeping and incident analysis

After following the suggested process for evaluating resulting risk, a comparison of the original risk and the resulting risk indicated that risk was reduced from an original level of 0.0212 to a resulting risk level of 0.00549 units of severity per worker-hour resulting in a total risk reduction of 0.0206 units of severity per worker-hour.

The creation of this risk analysis method represents a significant achievement of this dissertation as the data provided and methodology suggested can be used by safety managers to evaluate original risk, risk reduction, and risk reduction associated with the process of constructing concrete formwork. Therefore, the overarching objective of this research was achieved.

5.2.6. Can the results of this dissertation be validated using alternate research techniques?

The fifth and final major research objective was to validate the data and theory used to create the data-driven model of construction safety and health risk management. Using detailed data collected from a case study project in Washington State, risk perceptions were correlated with expected safety risk demand. The data provided an extremely strong correlation (R-value = 0.96) indicating that the demand data collected in earlier research efforts was, indeed, representative of actual field conditions.

In this research phase several measures were taken to ensure minimal bias and influence of confounding factors. First, all crew members were interviewed and the median values represented the crew's risk perception for the work period. Second, all workers were asked to rate the expected probability for multiple severity levels to avoid biases that result from neglect of probability or recency. Finally, the order of questioning was randomized for each worker.

The second validation effort for this project involved confirming the risk mitigation values associated with the implementation of the essential safety program elements. This research process involved forming an independent Delphi panel that was asked to rate the relative effectiveness of the safety program elements. The Delphi panels reached consensus (absolute deviation of approximately 1) over the course of three rounds. The results of this process indicated that effectiveness of the program elements was modeled well by the capacity data with three exceptions: safety and health orientation and training, subcontractor selection and management, and written safety and health plans. The relative effectiveness of these elements conflicted with the original capacity data. This conflict may exist because the experts in the validation panel did not consider the effectiveness of the elements on a risk-by-risk basis or the potential for interactions or diminishing returns of the safety program elements.

Finally, the author attempted to validate the concept of equilibrium. Unfortunately, the findings were such that the resulting risk for each project, according to the data presented in this research, was zero. Furthermore, all formwork construction processes for these four projects were injury-free. The fact that the formwork processes were injury-free and the equilibrium model predicted zero resulting risk provides moderate evidence that the model is, indeed effective. However, the author believes that reducing risk on a construction site to zero is not possible because, according to risk management theory, it is impossible to reduce probability or severity to zero without avoiding or transferring the risk.

5.2.7. Minor Objectives

In addition to the six major objectives the minor objectives identified in the introduction of this dissertation were achieved. First, as a part of the pilot study for this research, the current methods of safety risk management were identified. Second, the worker activities required for a specific high-risk construction process were identified and defined as discussed. Finally, probability and severity scales that encompass all types of risks were

created. Most scales developed prior to this study were very simple and subjective. The scales developed for this study include actual probability and severity ratings for all types of accidents ranging from near misses to fatalities.

5.3. OVERARCHING CONCLUSIONS AND APPLICATIONS

As indicated, all of the objectives of this research were achieved. The theoretical model was created that can be used to identify original risk (Demand) associated with any construction process, the risk mitigation (Capacity) associated with a specific safety program, and resulting risk (equilibrium). To illustrate the model, the activities associated with the process of constructing concrete formwork were identified and the specific probability and severity values for each safety risk were identified for each activity. In other words, the demand associated with the construction of concrete formwork was quantified. Similarly, the thirteen essential safety program elements were identified and their ability to reduce the probability and/or severity of the various safety risks was quantified. The data was applied to the theoretical model creating a data-driven model that can be used to identify high-risk activities, relative effectiveness of safety program elements, and equilibrium. The data collected for this model was validated using alternative research techniques.

In practice, the final data-driven model can be used in several ways. First the demand data can be used to determine the high risk work activities and the relative risk associated with the various risk types (e.g., fall to lower level, crushed-by, overexertion). Furthermore, the demand data can be used to track expected risk over time. The capacity data can be used to determine the relative effectiveness of the safety program elements. When combined, the resulting risk (i.e., degree of equilibrium) can be evaluated and the relative effectiveness of the safety program elements can be identified given specific activities expected on site. The author believes that this model may be a useful tool for construction safety risk management. The application of this model is limited, however.

While this research was highly successful, the reader should be aware of some significant limitations. The author believes that the demand data and capacity data, used separately, may be extremely effective sources of information that can aid decision-making. However, the reader must recognize the limitations of the research when using this data in practice. A detailed discussion of the limitations of the data presented and methods suggested is provided in this section.

5.4. LIMITATIONS

Several sections within the body of this dissertation allude to the fact that there are some limitations of the data and methodologies presented in this research. These limitations are directly related to the theoretical model introduced and the demand and capacity data collected and used to populate the model. Most of these limitations result from the specific structure of the research and the assumptions made during data collection.

Major limitations are associated with the structure of the theoretical model. The risk-based equilibrium model involves the quantification of probability and/or severity of construction risks for each worker-activity. This structure assumes two things: (1) the probability and severity of an incident can be defined for a specific worker activity and can be analyzed independently of the remainder of the work site, and (2) an individual is capable of quantifying the independent ability of each program element to reduce a portion of probability and/or severity. This study is limited in the fact that it is likely that no individual is capable of identifying and quantifying all risks regardless of expertise.

According to Srinivas (2006) there are three types of knowledge:

- 1) Things that you know
- 2) What you know you don't know
- 3) What you don't know you don't know

While the first two types of knowledge are easy to manage because they are the things that people know, the third category, “what you don’t know you don’t know” is problematic for this research because this knowledge would be omitted from judgment-based studies. Therefore, the existence of this type of knowledge limits the applicability of the theoretical model because the model relies on the ability of a manager to identify all potential activities, rate the probability and severity for each risk associated with these activities, and rate the ability of selected safety program elements to mitigate risk. In order to use this model to predict exact risk values, one would have to know every potential outcome. According to Srinivas (2007) this would never be possible.

The second major limitation of this research involves the quantification of demand. The probabilities and severities for each formwork construction activity incorporate only the information that the expert panelists can identify. Any factors that exist outside the knowledge areas of these experts have not been incorporated in this study. Additionally, because of the structure of this study, the demand data only applies to the following:

- Construction in the United States of America
- The construction of concrete formwork
- The average contractor in the average environment (i.e., average crew capabilities, management capabilities, project type, weather conditions, political climate, etc.)
- The activities identified and described for this research

Furthermore, the data is limited because the expert panelists were not asked to identify any interactions among risks or construction activities. For example, the panelists were not asked to identify if the risks associated with lifting and lowering materials would change in the presence of other activities such as application of form lubrication. Similarly, the risk values only apply to the activities as they are defined. If a worker was to perform the activity in A manner different from that provided to the Delphi panel, the true risk values may change.

The capacity data is also limited in several ways. In fact, the limitations of the capacity data became immediately visible when the data was integrated with the demand data in the safety equilibrium model. The capacity data only applies for:

- The safety program elements selected for this study
- The elements as they were described to the Delphi panel
- The independent implementation of each program element when no other safety program elements are in place
- Firms that have an average capability and allocate average resources to the safety program
- The average conditions expected on a construction site

Any deviations from the above characteristics are expected to drastically change the risk mitigation values presented in this dissertation. Interactions and diminishing returns of the safety program elements when implemented as a part of a cohesive safety program for a construction site are likely to have the most impact on true effectiveness of the elements. The implementation of the capacity data led the author to believe that, in practice, the effectiveness of safety program elements is reduced significantly once other elements are implemented. In other words, the true effectiveness of a given safety program element is likely to depend largely on the other program elements that constitute the safety program. This claim is supported by the observations made by the author when integrating the capacity data and the demand data.

During the process of merging the demand and capacity data the author determined that the safety efforts required to reduce the resulting risk to zero were minimal. In fact, according to the capacity data, it is possible to reduce the risk of forming concrete to zero by implementing just a few safety program elements. Unfortunately, this is contradictory to what the author has observed in practice. In fact, many firms implement all of the

safety program elements analyzed in this study and continue to have incidents on their sites.

While the author believes that the data presented in this dissertation is, indeed, accurate, it only applies when each program element is independently implemented as described (which rarely occurs in practice). The author cautions the reader when implementing the current model in practice as the resulting risk may be misleading. The reader is specifically cautioned when merging the two data sets to determine resulting risk. Further research is necessary to identify and quantify the impacts of interactions among safety program elements (e.g., one element may be less effective once another element has been implemented) or diminishing returns (e.g., once several elements have been implemented, a given element may no longer be as effective as it would have been if it were the only element implemented). Further discussion of future research is provided later in this section.

The final limitations of this dissertation are related to adjustment factors that are likely to influence the applicability of the Demand and Capacity data. Research summarized by Hinze (1997) indicates that the following factors may have a significant impact on the demand data collected for this study. The following list is not comprehensive.

1. Years of experience and overall quality of the crew members
2. Personal behaviors of the workers (e.g., drug use, risk tolerance, etc.)
3. Language barriers
4. Biorhythm of the workers
5. Job satisfaction and loyalty to the company
6. Personal relationships with co-workers
7. Productivity pressure
8. Predictability of work
9. Type of project

10. Year of experience and overall quality of management including foremen, superintendents, and upper management
11. Project coordination
12. Quality and safety commitment of the subcontractors
13. Size of the firm
14. Company turnover
15. Temperature and weather
16. Time of day, day of the week, time of month, time of year, and phase of the moon that the work is being performed
17. Length of the workweek

The above list of influencing factors can be divided into five main categories: characteristics of the workers, work type, management strategies, company characteristics, and scheduling. While each of these characteristics are likely to have an impact on the risk demand, the quantification of such effects is outside the scope of this study. More discussion about these factors can be found in the future research section.

In addition to the factors that may influence demand, there are several factors that may affect the ability of the safety program elements to mitigate a portion of the probability and/or severity of the safety risks (i.e., capacity). These factors include, but are not limited to interactions and diminishing returns discussed earlier. The major limiting characteristics of this study:

- The values represent the average for all firms in the industry regardless of size, geographic location, safety record, etc.
- The risk values represent average risk levels that would occur if no other safety programs are implemented.
- The risk values represent the judgment of safety experts and do not represent empirical data

According to Hinze (1997) and Hill (2002), the factors that may directly influence the capacity data include:

- Resources allocated to safety program elements
- Quality of the safety management
- Quality and experience of the crew
- Acceptance and buy-in of the crew members
- Experience with a given program element
- Specific characteristics and activities involved with each element
- Support from the Owner, subcontractors, suppliers, and other key entities involved in a project

Despite the limitation of the data presented in this dissertation, the author believes strongly that the information can be used for guidance to improve the effectiveness of safety management within the firm. Even if the data is not directly representative of the conditions on site, the relative risk values of various formwork construction activities and the relative effectiveness of safety program elements is likely to be consistent among many firms and the projects that they construct. Additional research is required to increase the robustness of this data to deviations from the average organizational and project characteristics. The following section suggests research topics that would improve the quality and applicability of this research.

5.5. RECOMMENDATIONS FOR FUTURE RESEARCH

As with any study, this dissertation can be seen as a stepping stone for future research. The research described in this document was built largely upon previous research in fields such as construction engineering and management, safety and health, risk management, social psychology, and decision analysis. This dissertation builds upon previous research to develop, populate and validate the construction safety equilibrium

model. Future research, however, may improve the effectiveness and applicability of this research. Below the reader will find several suggestions for future research.

5.5.1. Evaluation of interactions and diminishing returns in construction safety programs

Perhaps the most influential factors that limit the effectiveness of the data presented in this dissertation are the interactions and diminishing returns of safety program elements. Understanding how elements interact with one another and how the effectiveness of each program element is interrelated with other elements implemented could have a profound effect on the understanding of the dynamics of a safety program. The data presented in this dissertation serves as a baseline upon which the effects of potential interactions may be applied. The author suggests this research topic because research on the dynamics of safety program is extremely limited.

5.5.2. Quantification of factors influencing risk demand

Seventeen different firm-specific and project-specific factors that may have a potential impact on the true demand values associated with each activity were presented earlier. Evaluating and quantifying varying degrees to which these factors increase or decrease probability and/or severity values would drastically improve the robustness of the safety equilibrium model. Hinze (1997) identifies the potential impacts associated with each of the seventeen factors. However, no effort has been made to quantify the impact of these factors on specific activities.

5.5.3. Quantification of factors influencing risk Capacity

Similar to the factors discussed above, the identification and quantification of various factors that influence the ability of the safety program elements to reduce risk would result in a significant contribution to the field of construction safety risk management and would improve the robustness of the equilibrium model.

5.5.4. Integration of risk demand and capacity with current project control strategies

In Manuscript 2, the author presents an example application of the demand data using a hypothetical work schedule. This application involved determining the specific work activities expected for each work hour for a given workday. The risk demand data was then applied and used to determine the expected risk levels throughout the workday. The quantification of demand values for additional processes and the integration of that data into scheduling software such as Primavera P3® may allow managers to identify expected risk patterns over time.

5.5.5. Evaluating the impact of construction innovations on construction safety and health using a risk-based method

Finally, because this was an activity-based study, the Demand data obtained can be used to evaluate the effectiveness of formwork construction innovations. For example, the changes in specific activities and durations of activities required can be used to evaluate the change in risk Demand resulting from the change in worker activities. Research on this topic could be very beneficial and would allow a manager to consider the potential impacts of new products, processes, or technologies on safety performance. This data could then be used to evaluate the overall benefit of an innovation to the organization.

BIBLIOGRAPHY

Adler, M. and E. Ziglio (1997). Gazing into the Oracle: The Delphi Method and its Application to Social Policy and Public Health. London, Jessica Kingsley.

Altayeb, S. (1990). Drug Testing and Its Impact on Incident Rates in the Construction Industry. Clemson, SC, Clemson University. **Doctorate**.

Baradan, S. and M. A. Usmen (2006). "Comparitive Injury and Fatality Risk Analysis of Building Trades." Journal of Construction Engineering and Management 132(5): 533-539.

Bardecki, M. J. (1984). "Participants' response to the Delphi method: an additudinal perspective." Technological Forecasting and Social Change 25: 281-292.

Baron, J. (2003). Myside bias in thinking about abortion. Philadelphia, PA, University of Pennsylvania.

Best, R. J. (1974). "An experiment in Delphi estimation in marketing decision making." Journal of Marketing Research 11: 448-452.

Bjarnason, T. and S. H. Jonsson (2005). "Contrast Effects in Perceived Risk of Substance Use." Substance Use and Misuse 40(1): 1733-1748.

BLS. (2007). "Bureau of Labor Statistics." Retrieved November 12, 2007, 2007, from http://data.bls.gov/PDQ/servlet/SurveyOutputServlet?&series_id=CEU2000000007.

Boje, D. M. and J. K. Murnighan (1982). "Group confidence pressures decisions." Management Science **28**: 1187-1196.

Brockhoff, K. (1975). The performance of forecasting in computer dialogue and face to face discussions. London, Addison-Wesley.

CAODC. (2004). "CAODC Injury Analysis Definitions." Retrieved November 18, 2007, from http://www.caodc.ca/PDF/2006_CAODC_Injury_Analysis_Definitions.pdf.

Carter, G. and S. D. Smith (2006). "Safety Hazard Identification on Construction Projects." Journal of Construction Engineering and Management **132**(2): 197-205.

Chein, I., S. W. Cook, et al. (1948). "The Field of American Research." American Psychologist **3**: 43-50.

Deutsch, M. and H. B. Gerard (1955). "A study of normative and informational social influences upon individual judgment." Journal of Abnormal and Social Psychology **51**: 629-636.

Dunston, P. S. and L. E. Bernold (2000). "Adaptive Control for Safe and Quality Rebar Fabrication." Journal of Construction Engineering and Management **126**(2): 122-130.

Durkheim, E. (1982). The Rules of the Sociological Method. New York, Free Press.

Earle, S. W. (1953). "Cycle Charting." Factory Management and Maintenance **3**(8): 105-107.

Erffmeyer, R. C. and I. M. Lane (1984). "Quality and acceptance of an evaluative task: the effects of four group decision-making formats." Group and Organizational Studies 9(4): 509-529.

Fredricks, T. K., O. Abudayyeh, et al. (2005). "Occupational Injuries and Fatalities in the Roofing Contracting Industry." Journal of Construction Engineering and Management 131(11): 1233-1240.

Gambatese, J. A. (2006). Design for Construction Safety: Moving Safety Decisions Upstream. Corporate Partner's Program. Corvallis, OR, Oregon State University

Gambatese, J. A., Ed. (2000). "Designing for safety". Construction safety and health management

Upper Saddle River, NJ, Prentice-Hall.

Gambatese, J. A., M. Behm, et al. (2005). "Viability for Designing for Construction Worker Safety." Journal of Construction Engineering and Management 131(9): 1029-1036.

Gambatese, J. A., J. W. Hinze, et al. (1997). "Tool to Design for Construction Worker Safety." Journal of Architectural Engineering 3(1): 32-41.

Gerber, J. and G. Yacoubian (2001). "Evaluation of Drug Testing in the Workplace." Journal of Construction Engineering and Management 127(6): 435-444.

Gibb, A., R. Haslam, et al. (2004). The role of design in accident causality. Designing for safety and health in construction: Proc., Research and Practice Symp, Eugene, OR, University of Oregon Press.

Gilovich, T. (1991). How we Know What Isn't So: The Fallibility of Human Reason in Everyday Life. New York, The Free Press.

Gordon, T. J. and O. Helmer (1964). Report on a Long-Range Forecasting Study. Santa Monica, CA, The Rand Corporation.

Gupta, U. G. and R. E. Clarke (1996). "Theory and applications of the Delphi technique: a bibliography (1975-1994)." Technological Forecasting & Social Change **53**(2): 185-211.

Har, W. Y. (2002). "Ergonomic Studies on Formwork Carpentry." Applied Ergonomics **3**: 683-686.

Heath, L., R. S. Tindale, et al. (1994). Applications of Heuristics and Biases to Social Issues. New York, Plenum Press.

Heinrich, H. W. (1959). Industrial Accident Prevention. A Scientific Approach. New York, McGraw-Hill.

Hill, D. C. (2004). Construction Safety Management Planning. Des Plaines, American Society of Safety Engineers.

Hinze, J., J. N. Davenport, et al. (2006). "Analysis of Construction Worker Injuries That Do Not Result in Lost Time." Journal of Construction Engineering and Management **132**(3): 321-326.

Hinze, J. W. (1997). Construction Safety. Columbus, Prentice Hall.

Hislop, R. D. (1999). Construction Site Safety: A Guide for Managing Contractors. Boca Raton, CRC Press.

Isenberg, D. J. (1986). "Group polarization: a critical review and meta analysis." Journal of Personality and Social Psychology **50**: 1141-1151.

Jannadi, O. A. and S. Almishari (2003). "Risk Assessment in Construction." Journal of Construction Engineering and Management 129(5): 492-500.

King, R. W. and R. Hudson (1985). Construction Hazard and Safety Handbook. Norwich.

Krimsky, S. and D. Golding (1992). Social Theories of Risk. London, Praeger.

Lang, T. (1998). "An overview of four futures methodologies." 2006, from <http://www.soc.hawaii.edu/~future/j7/LANG.html>.

Larreche, J. C. and R. Moinpour (1983). "Managerial judgment in marketing: the concept of expertise." Journal of Marketing Research **20**: 110-121.

Lee, J. Y. and K. C. Chan (2003). "Assessing the Operations Innovation Bandwagon Approach: A Market Perspective on the Returns." Journal of Managerial Issues **15**(1): 97-107.

Lee, S. and D. W. Halpin (2003). "Predictive Tool for Estimating Accident Risk." Journal of Construction Engineering and Management 129(4): 431-436.

Levitt, R. E. and N. M. Samelson (1987). Construction Safety Management. New York, McGraw Hill.

Linstone, H. A. and M. Turoff (1975). The Delphi Method: Techniques and Applications. London, Addison-Wesley.

Martin, W. (2006). Theories of Judgment. Cambridge, University Press.

McCrary, S. W., R. R. Smith, et al. (2006). "Comparative Analysis Between Manufacturing and Construction Enterprises on the Use of Formalized Quality Management Systems." Journal of Industrial Technology 22(3): 1-8.

McKenna, H. (1994). "The Delphi Technique: a worthwhile research approach for nursing?" Journal of Advanced Nursing 19: 1221-1225.

Mundel, M. E. and D. L. Danner (1994). Motion and Time Study: Improving Productivity. Englewood Cliffs, Prentice Hall.

Murphy, M. K., N. A. Black, et al. (1998). "Consensus development methods, and their use in clinical guideline development." Health Technology Assessment 2(3).

Myers, D. G. (1978). "Polarizing effects of social comparisons." Journal of Experimental Social Psychology 14: 554-563.

Niebel, B. W. (1993). Motion and Time Study. Boston, MA, Irwin.

Oglesby, C. H., H. W. Parker, et al. (1989). Productivity Improvement in Construction. New York, McGraw Hill.

Okoli, C. and S. D. Pawlowski (2004). "The Delphi method as a research tool: an example, design considerations and applications." Information & Management **42**: 15-29.

Perkins, D. N. (1989). Reasoning as it is and could be: An empirical perspective. Thinking across cultures: The third international conference on thinking, Hillsdale, NJ, Erlbaum.

Peyton, R. X. and T. C. Rubio (1991). Construction Safety Practices and Principles. New York, NY, Van Nostrand.

Pill, J. (1971). "The Delphi Method: Substance, Context, a Critique and Annotated Bibliography." Socio-Economic Planning Science **5**: 55-71.

Quayle, D. (1988). American Productivity: The Devastating Effect of Alcoholism and Drug Abuse. Chicago, Employee Assistance Programs.

Rajendran, S. (2006). Sustainable Construction Safety and Health Rating System. Civil, Construction and Environmental Engineering. Corvallis, Oregon State University. Doctorate.

Rajendran, S. (2006). Sustainable Construction Safety and Health Rating System. Civil and Environmental Engineering. Corvallis, OR, Oregon State University. Doctorate: 316.

Rasmussen, J. (1997). "Risk management in a dynamic society: A modeling problem." Safety Science **27**(3): 183-213.

Reason, J. (1990). Human Error. New York, Cambridge University Press.

Restorff, H. V. (1933). "Über die Wirkung von Bereichsbildungen im Spurenfeld." Psychologie Forschung **18**: 299-334.

Rogers, M. R. and E. C. Lopez (2002). "Identifying critical cross-cultural school psychology competencies." Journal of school psychology **40**(2): 115-141.

Rohrbaugh, J. (1979). "Improving the quality of group judgment: The Delphi process in social judgment analysis and the Delphi technique." Organizational Behavior and Human Performance **24**: 73-92.

Rottenstreich, Y. and C. K. Hsee (2001). "Money, kisses, and electric shocks: on the affective psychology of risk." Psychological Science **12**: 185-190.

Rowe, G. and G. Wright (1999). "The Delphi technique as a forecasting tool: issue and analysis." International Journal of Forecasting **15**: 1-23.

Sackman, H. (1974). Delphi assessment: expert opinion, forecasting, and group process. Santa Monica, CA, The RAND Corporation.

Shuman, H. and S. Presser (1981). Questions and Answers in Attitude Surveys: Experiments on Question Form, Wording and Context. Orlando, FL, Academic Press.

Sillars, D. (2006). Risk Management in Construction: Module One. Corvallis, OR, OSU.

Simmonds, C. (1977). The Nature of Futures Problems in Futures Research: New Directions. London, Addison-Wesley

Sommers, P. H. (1982). Better Construction Practices for Greater Formwork Safety. Concrete International. **May, 1982**: 31-41.

Szmberski, R. (1997). "Construction Project Safety Planning." TAPPI Journal **80**(11): 69-74.

Tatum, C. B. (2000). "Coordinating Building Systems: Process and Knowledge." Journal of Construction Engineering and Management 6(4): 116-121.

Toole, T. M. (2005). "Increasing Engineers' Role in Construction Safety: Opportunities and Barriers." Journal of Professional Issues in Engineering Education and Practice 131(3): 199-207.

Toole, T. M., N. Hervol, et al. (2006). Designing Steel for Construction Worker Safety. 2006 North American Steel Construction Conference, San Antonio, TX.

Veltri, A. T. (1985). Expected use of Management Principles for Safety Function Management. Physical Education. Morgantown, West Virginia Univeristy. **Doctoral**.

Veltri, A. T. (2006). Analyzing failures to protect and use a firm's resources productively: an analytical sequence model. OSU. Corvallis, OR.

Wright, G., M. J. Lawrence, et al. (1996). "The role and validity of judgment in forecasting." International Journal of Forecasting **12**: 1-8.

Yi, K.-J. and D. Langford (2006). "Scheduling-Based Risk Estimation and Safety Planning for Construction Projects." Journal of Construction Engineering and Management **132(6)**: 626-635.

APPENDIX

Appendix A – Introductory Delphi survey

DELPHI INTRODUCTORY SURVEY

Thank you once again for serving on the Delphi panel for this research. Your participation is greatly appreciated! The purpose of this introductory survey is to objectively confirm your status as an expert in the field of construction safety or risk management based on your academic and professional experience and achievements. Please remember that both industry and academic experience are highly valuable.

Please answer all of the following questions to the best of your ability. Fields that require a response have been highlighted in yellow. Please place an “X” in the appropriate boxes or fill in the appropriate fields. When you have finished answering all of the questions please email your response, in Word format, to hallowem@onid.orst.edu . This survey is intended to be completed in less than 15 minutes.

PERSONAL INFORMATION

The following questions are intended to confirm your position as an expert. Once validated, the Delphi responses will be anonymous and all members will be treated equally.

Name	
Current Employer	
Position	
City	
State	
Country	

ACADEMIC INFORMATION

Please indicate the degrees that you have earned from accredited institutions of higher learning:

Degree	Major / Field of Concentration
None	
Associates	
Bachelors	
Masters	
Doctorate	

Please indicate your experience in academia:

Position	Approximate Number of Years
No position in academia	
Lecturer	
Assistant Professor	
Associate Professor	
Professor	
Other (please specify)	

PUBLICATIONS AND CONFERENCE PARTICIPATION

Please indicate your publishing and conference activity **in the topics of safety, health and risk management**:

Activity	Approximate Number
Publications in peer-reviewed journals	
Books or book chapters	
Conference presentations	
Trade publications	
Other (please specify)	

PROFESSIONAL EXPERIENCE

Please indicate your experience in the construction industry:

Position	Approximate Number of Years
Laborer	
Foreman	
Superintendent	
Safety and Health Management	
Risk Management	
Upper Management (GC, CM or Sub)	
Project Engineer	
Architect	
Other (please specify)	
Other (please specify)	

Please indicate your professional licensure/certification:

Licensure or certification	Please place an "X" where appropriate
Professional Engineer (PE)	
Certified Safety Professional (CSP)	
Certified Industrial Hygienist (CIH)	
Associated Risk Manager (ARM)	
Licensed Architect (AIA)	
Other (please specify)	

Please list any safety, health or risk management committees of which you are or have been a member (e.g. ASCE Site Safety Committee, ASSE Construction Safety, etc.). Please also indicate if you are or have been the Chair of a particular committee.

Committee Name	Were you a Chair (past or present) of this committee? (if yes, please indicate with an "X")

<p>If you believe that there is an element of your academic or professional experience that helps to qualify you as an expert that cannot be classified in a previous category, please list and briefly describe it here.</p>

SELECTION OF SAFETY PROGRAM ELEMENTS

From your experience, please select the strategy that most contractors employ when selecting safety program elements for a particular construction project. Please select all that apply by placing an "X" in the corresponding box. If another method is more appropriate, please provide a description.

Method	Contractor Size		
	Small	Medium	Large
Safety program elements are chosen at random			
Elements are chosen based on intuition and judgment			
Elements are chosen based on word of mouth			
Elements are chosen based on literature			
Contractors implement as many safety program elements as the budget permits			
Other method (please describe)			

If you have any additional comments, please provide them below.

Thank you for taking the time to fill out this introductory survey. The first round of the Delphi process will begin on April 01, 2007. If you have any questions about this survey or about the research project in general, please do not hesitate to contact me or my advisor, John Gambatese, at:

Matthew Hallowell
 Ph.D. Candidate
 Dept. of Civil, Construction and Environmental Engineering
 Oregon State University
 220 Owen Hall, Corvallis, OR 97331-2302 USA
 Tel.: 541-758-4047; hallowem@onid.orst.edu

John Gambatese, Ph.D., P.E.
 Associate Professor
 Dept. of Civil, Construction and Environmental Engineering
 Oregon State University
 220 Owen Hall, Corvallis, OR 97331 USA
 Tel.: 541-737-8913; Fax: 541-737-3300; john.gambatese@oregonstate.edu

Appendix B – Expert review of formwork activities

FORMWORK ACTIVITIES – PROFESSIONAL REVIEW

Please read: The following is a list of common formwork activities. Please fill in all fields in yellow. If the description provided is adequate, please leave the field blank. If you have any additional activities that workers may be encountered that cannot be classified in any of the categories provided please add the activity at the end of the form in the space provided. Please note, activities associated with pouring concrete, installing rebar or stripping forms are not included. This list is intended to represent the vast majority of activities that may be encountered by workers when constructing concrete formwork. This list is intended to be exhaustive and general. However, the list should include any and all activities that *may* be encountered.

Name	
Years of experience with formwork	
Firm location (Geographical Region)	

ACTIVITIES**Transport materials and equipment without motorized assistance**

Transporting equipment and materials may include carrying items of varying weights such as 2x4's, plywood, form panels, nail guns, etc. from one location to another. Workers may use a wheelbarrow or may carry materials by hand. This activity is likely to occur when the work site has a forming mill, when the materials and equipment are stored in one location, when the site is relatively large and/or when formwork is constructed in multiple locations on site.

Additional Comments

Transport materials using construction vehicle or other motorized assistance

Materials may be transported by vehicles such as trucks, skid steers or scissor lifts when the equipment is readily available or when the site is relatively large and formwork sites, mills and material/equipment storage is spread. Motorized transport is typically used when it is time-prohibitive or otherwise unrealistic for workers to transport materials by hand. This activity primarily involves operating transportation equipment through the construction site.

Additional Comments

Lift or lower materials, form components or equipment

Perhaps one of the most common activities for any construction process, lifting and lowering involves unassisted vertical transport of construction materials, formwork components or equipment. The process of forming concrete may require that workers lift materials from foot-level to a higher grade or from foot-level to a lower grade. In many cases workers will pass materials, equipments or components to co-workers located at the higher or lower grades without the assistance of pulleys, cranes or other mechanical devices.

Additional Comments

Hold materials or components in place (static lift)

The process of forming concrete may require workers to temporarily support a portion of the concrete form while other workers connect materials or components. This activity involves a static lift and may be accompanied by lifting/lowering. This activity may occur when work teams connect panels to stakes/columns, install bracing, level or plumb forms, etc. Typically, the worker holding the materials or components must wait for other workers to complete tasks before relief.

Additional Comments

Accept/load/connect materials or forms from crane

When a crane is used to transport materials or form components workers must accept the materials from the crane and/or load the crane with excess materials or waste. Workers must direct the crane operator as the material is lifted/lowered and physically accept the load. This activity is most likely to occur when formwork operations occur above or below grade and the use of scissor lifts or worker transport is unrealistic.

Additional Comments

Cut materials using skill or table saw

During most formwork operations materials such as 2x4's, plywood or aluminum must be cut to size. Typically, equipment such as a circulating saw, reciprocating or table saw is used to cut materials. Other equipment may be used in some cases. This activity required the worker to operate such equipment and guide materials during cutting/ripping.

Additional Comments

Nail/screw/drill form components or other materials

Nailing or screwing form components or materials may involve the use of a traditional hammer, nail gun, electric screwdriver, staple gun or other basic equipment. The worker may be required to repeat this activity for an extended period of time at certain stages of the formwork process.

Additional Comments

Hammer using sledgehammer or other equipment

This activity involves hammering stakes or other components into the soil or other material. This activity is different from nailing components and materials because heavier tools such as a sledgehammer are used to drive objects. In other words, hammering in this category refers to an activity that requires fewer strikes of larger force than nailing.

Additional Comments

Plumb and/or level forms using body weight, pry bar or other equipment

Leveling and plumbing forms is a common activity for nearly all formwork operations and involves using body weight, pry bars or other equipment to shift and adjust the formwork. This activity may be executed by a single individual or multiple individuals.

Additional Comments

Ascend or descend ladder

Operations that occur above or below grade typically require workers to ascend or descend ladders in order to reach the work site. Ladders may be wooden, metal and may vary in length substantially from one site to the next. Workers may be required to carry materials or equipment as they ascend or descend ladders.

Additional Comments

Work below grade or in confined space

Some operations may require crews or individuals to work in confined spaces such as elevator shafts or below grade in an excavation. Crews may be required to work below grade when forming foundation piers or other sub-grade structures. This activity is typically accompanied by lifting or lowering materials.

Additional Comments

Work above grade (>5 ft) or near uncontrolled opening

Most formwork operations require workers to be located at elevation or near an uncontrolled opening. Simply, workers may be required to work above ground level (or above a location of substantial support). This activity may involve working on unstable surfaces, areas with poor or limited footing, in exposed conditions, etc.

Additional Comments

Inspect forms and construction planning

During construction workers and crew leaders often take time to inspect their work and plan for subsequent operations.

Additional Comments

Excavation

In rare situations the concrete forming process may require excavation. Excavation involves the use of appropriate equipment such as a backhoe, bulldozer, shovels, etc.

Additional Comments

ADDITIONAL ACTIVITIES IF APPLICABLE (NOT INCLUDED ABOVE)

Additional Activity 1 (Please describe)

Additional Activity 2 (Please describe)

Additional Activity 3 (Please describe)

Appendix C –Round 1 Delphi survey of demand panel (complete)

DELPHI SURVEY – ROUND 1

Thank you for completing the introductory Delphi survey. You have been qualified as an expert based upon the strict guidelines suggested in literature and several restrictions set for this study.

This Round 1 survey is intended to be completed in approximately 25-30 minutes. Subsequent surveys will require significantly less time to complete. When you have finished answering all of the questions, please email your response, in Word format, to hallowem@onid.orst.edu .

After all Delphi participants have completed the Round 1 survey, the results will be reported to you in the form of simple statistics (e.g. median response and range). You will then be given the opportunity to change your response.

INSTRUCTIONS

Please answer all of the following questions to the best of your ability. Fields that require a response have been highlighted in yellow. Please indicate your response by placing an ‘X’ in the appropriate boxes.

The survey requests that you rate the probability and severity of construction safety incidents. For your reference, safety incidents have been defined below and divided into eleven categories. The definitions are derived from the Bureau of Labor Statistics and Occupational Safety and Health Administration’s Occupational Injury and Illness Classification System (OIICS). The detailed version of the OIICS will be provided upon request.

****VERY IMPORTANT - PLEASE READ****

For the following activities associated with the construction of concrete formwork please use **your experience and judgment** to rate what **you believe** the average probability and severity of an injury associated with each of the OIICS hazard codes would be for the **average contractor if no safety program elements were implemented**. Please provide ratings for the general construction industry and select only one probability range or severity value for each incident.

Please use the following probability and severity scales for reference when rating the probability and severity for construction incidents:

Probability Scale: Average number of worker-hours per incident									
Negligible or 0	10-100 million	1-10 million	100,000 - 1 million	10,000 - 100,000	1,000 - 10,000	100 - 1,000	10-100	1-10	<0.1-1
1	2	3	4	5	6	7	8	9	10

Severity Scale: Average loss associated with an incident (industry and hazard average)									
Negligible	Discomfort → Persistent Pain				Medical case		Lost work time		Fatality
1	2	3	4	5	6	7	8	9	10

OIICS INCIDENT DEFINITIONS

Struck by object: "Struck by" applies to injuries produced by forcible contact or impact between the injured person and the source of injury when the motion producing the contact is primarily that of the source of injury rather than the person.

Includes: Struck by falling objects, struck by flying objects, and struck by swinging or slipping objects.

Struck against object: "Struck against" applies to injuries produced by forcible contact or impact between the injured person and the source of injury when the motion producing the contact is primarily that of the injured person. This major group includes: bumping into objects, stepping on objects, kicking objects, and being pushed or thrown into or against objects.

Caught in or compressed by equipment or objects: This major group includes cases in which the injury was produced when a person or part of a person was injured by being squeezed, crushed, pinched or compressed between two or more objects, or between parts of an object. **Includes:** Caught in or crushed in collapsing materials.

Fall to lower level: Applies to instances in which the injury was produced by impact between the injured person and the source of injury, the motion producing the contact being that of the person, under the following circumstances:

- the motion of the person and the force of impact were generated by gravity, and
- the point of contact with the source of injury was lower than the surface supporting the person at the inception of the fall.

Fall on same level: Fall on same level applies to instances in which the injury was produced by impact between the injured person and the source of injury, the motion producing the contact being that of the person, under the following circumstances:

- the motion of the person was generated by gravity following the employee's loss of equilibrium (the person was unable to maintain an upright position) and,

- the point of contact with the source of injury was at the same level or above the surface supporting the person at the inception of the fall.

Includes: Slips and trips.

Overexertion: Overexertion applies to cases, usually non-impact, in which the injury or illness resulted from excessive physical effort directed at an outside source of injury or illness. The physical effort may involve lifting, pulling, pushing, turning, wielding, holding, carrying, or throwing the source of injury/illness.

Repetitive motion: Repetitive motion applies when an injury or illness resulted from bodily motion which imposed stress or strain upon some part of the body due to a task's repetitive nature.

Exposure to harmful substances or environments: This category applies to cases in which the injury or illness resulted from contact with, or exposure to, a condition or substance in the environment.

Includes: Contact with electric current, exposure to temperature extremes, exposure to excessive noise, etc.

Transportation accidents: This category covers events involving transportation vehicles, powered industrial vehicles, or powered mobile industrial equipment in which at least one vehicle (or mobile equipment) is in normal operation and the injury/illness was due to collision or other type of traffic accident, loss of control, or a sudden stop, start, or jolting of a vehicle regardless of the location where the event occurred.

Other: This category includes any event or exposure which is not classified or listed under any other division. Please consider the following in this category: Fires and explosions, assaults and violent acts and all other events or exposures not elsewhere categorized.

Transport materials and equipment without motorized assistance

Transporting equipment and materials may include carrying items of varying weights such as 2x4's, plywood, form panels, ties, cat heads, adjustable pipe braces, etc. from one location to another. Workers may use a wheelbarrow, bucket with handles or may carry materials by hand. This activity is often performed at height, below grade or on rough or uneven surfaces.

	PROBABILITY of an incident associated with the activity described: (1=low average probability, 10= high average probability) See chart on page 1 for reference scale									
Hazard	1	2	3	4	5	6	7	8	9	10
Struck by										
Struck against										
Caught in										
Fall to Lower										
Fall to Same										
Overexertion										
Repetitive Motion										
Exposure to Harmful Substances										
Transportation Accidents										
Other										

	SEVERITY of an incident associated with the activity described: (1= low average severity, 10=high average severity) See chart on page 1 for reference scale									
Hazard	1	2	3	4	5	6	7	8	9	10
Struck by										
Struck against										
Caught in										
Fall to Lower										
Fall to Same										
Overexertion										
Repetitive Motion										
Exposure to Harmful Substances										
Transportation Accidents										
Other										

Transport materials using construction vehicle or other motorized assistance

Materials may be transported by vehicles such as trucks, skid steers, forklifts, cranes or scissor lifts when the equipment is readily available or when the site is relatively large and formwork sites, mills and material/equipment storage is spread. Motorized transport is typically used when it is time-prohibitive or otherwise unrealistic for workers to transport materials by hand. This activity primarily involves operating transportation equipment through the construction site. This activity may be performed at height, below grade or on rough or uneven surfaces.

	PROBABILITY of an incident associated with the activity described: (1=low average probability, 10= high average probability) See chart on page 1 for reference scale									
Hazard	1	2	3	4	5	6	7	8	9	10
Struck by										
Struck against										
Caught in										
Fall to Lower										
Fall to Same										
Overexertion										
Repetitive Motion										
Exposure to Harmful Substances										
Transportation Accidents										
Other										

	SEVERITY of an incident associated with the activity described: (1= low average severity, 10=high average severity) See chart on page 1 for reference scale									
Hazard	1	2	3	4	5	6	7	8	9	10
Struck by										
Struck against										
Caught in										
Fall to Lower										
Fall to Same										
Overexertion										
Repetitive Motion										
Exposure to Harmful Substances										
Transportation Accidents										
Other										

Lift or lower materials, form components or equipment

Perhaps one of the most common activities for any construction process, lifting and lowering involves unassisted vertical transport of construction materials, formwork components or equipment. The process of forming concrete may require that workers lift materials from foot-level to a higher grade or from foot-level to a lower grade. In many cases workers will pass materials, equipments or components to co-workers located at the higher or lower grades without the assistance of pulleys, cranes or other mechanical devices. This activity is often performed at height, below grade or on rough or uneven surfaces.

	PROBABILITY of an incident associated with the activity described: (1=low average probability, 10= high average probability) See chart on page 1 for reference scale									
Hazard	1	2	3	4	5	6	7	8	9	10
Struck by										
Struck against										
Caught in										
Fall to Lower										
Fall to Same										
Overexertion										
Repetitive Motion										
Exposure to Harmful Substances										
Transportation Accidents										
Other										

	SEVERITY of an incident associated with the activity described: (1= low average severity, 10=high average severity) See chart on page 1 for reference scale									
Hazard	1	2	3	4	5	6	7	8	9	10
Struck by										
Struck against										
Caught in										
Fall to Lower										
Fall to Same										
Overexertion										
Repetitive Motion										
Exposure to Harmful Substances										
Transportation Accidents										
Other										

Hold materials or components in place (static lift)

The process of forming concrete may require workers to temporarily support a portion of the concrete form while other workers connect materials or components. This activity involves a static lift and may be accompanied by lifting/lowering. This activity may occur when work teams connect panels to stakes/columns, install bracing, level or plumb forms, etc. Typically, the worker holding the materials or components must wait for other workers to complete tasks before relief. This activity is often performed at height, below grade or on rough or uneven surfaces.

	PROBABILITY of an incident associated with the activity described: (1=low average probability, 10= high average probability) See chart on page 1 for reference scale									
Hazard	1	2	3	4	5	6	7	8	9	10
Struck by										
Struck against										
Caught in										
Fall to Lower										
Fall to Same										
Overexertion										
Repetitive Motion										
Exposure to Harmful Substances										
Transportation Accidents										
Other										

	SEVERITY of an incident associated with the activity described: (1= low average severity, 10=high average severity) See chart on page 1 for reference scale									
Hazard	1	2	3	4	5	6	7	8	9	10
Struck by										
Struck against										
Caught in										
Fall to Lower										
Fall to Same										
Overexertion										
Repetitive Motion										
Exposure to Harmful Substances										
Transportation Accidents										
Other										

Accept/load/connect materials or forms from crane

When a crane is used to transport materials or form components workers must accept the materials from the crane and/or load the crane with excess materials or waste. Workers must direct the crane operator as the material is lifted/lowered and may be required to physically accept the load. This activity is most likely to occur when formwork operations occur above or below grade and the use of scissor lifts or worker transport is unrealistic. A combination of aerial lifts and cranes may be used in this activity. This activity is often performed at height, below grade or on rough or uneven surfaces.

	PROBABILITY of an incident associated with the activity described: (1=low average probability, 10= high average probability) See chart on page 1 for reference scale									
Hazard	1	2	3	4	5	6	7	8	9	10
Struck by										
Struck against										
Caught in										
Fall to Lower										
Fall to Same										
Overexertion										
Repetitive Motion										
Exposure to Harmful Substances										
Transportation Accidents										
Other										

	SEVERITY of an incident associated with the activity described: (1= low average severity, 10=high average severity) See chart on page 1 for reference scale									
Hazard	1	2	3	4	5	6	7	8	9	10
Struck by										
Struck against										
Caught in										
Fall to Lower										
Fall to Same										
Overexertion										
Repetitive Motion										
Exposure to Harmful Substances										
Transportation Accidents										
Other										

Cut materials using circular or table saw

During most formwork operations materials such as 2x4's, plywood or aluminum must be cut to size. Typically, equipment such as a circulating saw, reciprocating or table saw is used to cut materials. Other equipment may be used in some cases. This activity required the worker to operate such equipment and guide materials during cutting/ripping. This activity is often performed at height, below grade or on rough or uneven surfaces.

	PROBABILITY of an incident associated with the activity described: (1=low average probability, 10= high average probability) See chart on page 1 for reference scale									
Hazard	1	2	3	4	5	6	7	8	9	10
Struck by										
Struck against										
Caught in										
Fall to Lower										
Fall to Same										
Overexertion										
Repetitive Motion										
Exposure to Harmful Substances										
Transportation Accidents										
Other										

	SEVERITY of an incident associated with the activity described: (1= low average severity, 10=high average severity) See chart on page 1 for reference scale									
Hazard	1	2	3	4	5	6	7	8	9	10
Struck by										
Struck against										
Caught in										
Fall to Lower										
Fall to Same										
Overexertion										
Repetitive Motion										
Exposure to Harmful Substances										
Transportation Accidents										
Other										

Nail/screw/drill form components or other materials

Nailing or screwing form components or materials may involve the use of a hammer (typically larger than 20 oz.), nail gun, electric screwdriver, impact wrench, staple gun or other basic equipment. The worker may be required to repeat this activity for an extended period of time at certain stages of the formwork process. When gang forms are used special forming hardware may be used. This activity is often performed at height, below grade or on rough or uneven surfaces.

	PROBABILITY of an incident associated with the activity described: (1=low average probability, 10= high average probability) See chart on page 1 for reference scale									
Hazard	1	2	3	4	5	6	7	8	9	10
Struck by										
Struck against										
Caught in										
Fall to Lower										
Fall to Same										
Overexertion										
Repetitive Motion										
Exposure to Harmful Substances										
Transportation Accidents										
Other										

	SEVERITY of an incident associated with the activity described: (1= low average severity, 10=high average severity) See chart on page 1 for reference scale									
Hazard	1	2	3	4	5	6	7	8	9	10
Struck by										
Struck against										
Caught in										
Fall to Lower										
Fall to Same										
Overexertion										
Repetitive Motion										
Exposure to Harmful Substances										
Transportation Accidents										
Other										

Hammer using sledgehammer or other equipment

This activity involves hammering stakes or other components into the soil or other material. This activity is different from nailing components and materials because heavier tools such as a sledgehammer are used to drive objects. In other words, hammering in this category refers to an activity that requires fewer strikes of larger force than nailing. This activity is often performed at height, below grade or on rough or uneven surfaces.

	PROBABILITY of an incident associated with the activity described: (1=low average probability, 10= high average probability) See chart on page 1 for reference scale									
Hazard	1	2	3	4	5	6	7	8	9	10
Struck by										
Struck against										
Caught in										
Fall to Lower										
Fall to Same										
Overexertion										
Repetitive Motion										
Exposure to Harmful Substances										
Transportation Accidents										
Other										

	SEVERITY of an incident associated with the activity described: (1= low average severity, 10=high average severity) See chart on page 1 for reference scale									
Hazard	1	2	3	4	5	6	7	8	9	10
Struck by										
Struck against										
Caught in										
Fall to Lower										
Fall to Same										
Overexertion										
Repetitive Motion										
Exposure to Harmful Substances										
Transportation Accidents										
Other										

Plumb and/or level forms using body weight, pry bar or other equipment

Leveling and plumbing forms is a common activity for nearly all formwork operations and involves using body weight, pry bars or other equipment to shift and adjust the formwork. This activity may be executed by a single individual or multiple individuals. A screw jack may be used for this activity and some workers may be surveying or using hand levels, lasers or plumb bobs to ensure proper placement. This activity is often performed at height, below grade or on rough or uneven surfaces.

	PROBABILITY of an incident associated with the activity described: (1=low average probability, 10= high average probability) See chart on page 1 for reference scale									
Hazard	1	2	3	4	5	6	7	8	9	10
Struck by										
Struck against										
Caught in										
Fall to Lower										
Fall to Same										
Overexertion										
Repetitive Motion										
Exposure to Harmful Substances										
Transportation Accidents										
Other										

	SEVERITY of an incident associated with the activity described: (1= low average severity, 10=high average severity) See chart on page 1 for reference scale									
Hazard	1	2	3	4	5	6	7	8	9	10
Struck by										
Struck against										
Caught in										
Fall to Lower										
Fall to Same										
Overexertion										
Repetitive Motion										
Exposure to Harmful Substances										
Transportation Accidents										
Other										

Ascend or descend ladder

Operations that occur above or below grade typically require workers to ascend or descend ladders in order to reach the work site. Ladders may be wooden, metal or fiberglass and may vary in length substantially from one site to the next. Workers may carry materials or equipment as they ascend or descend ladders. In many cases, workers may simply climb up the formwork supports. This activity is often performed at height, below grade or on rough or uneven surfaces.

	PROBABILITY of an incident associated with the activity described: (1=low average probability, 10= high average probability) See chart on page 1 for reference scale									
Hazard	1	2	3	4	5	6	7	8	9	10
Struck by										
Struck against										
Caught in										
Fall to Lower										
Fall to Same										
Overexertion										
Repetitive Motion										
Exposure to Harmful Substances										
Transportation Accidents										
Other										

	SEVERITY of an incident associated with the activity described: (1= low average severity, 10=high average severity) See chart on page 1 for reference scale									
Hazard	1	2	3	4	5	6	7	8	9	10
Struck by										
Struck against										
Caught in										
Fall to Lower										
Fall to Same										
Overexertion										
Repetitive Motion										
Exposure to Harmful Substances										
Transportation Accidents										
Other										

Inspect forms and construction planning

During construction workers and crew leaders often take time to inspect their work and plan for subsequent operations. Formwork must be inspected by a competent person prior to placing concrete. This activity is often performed at height, below grade or on rough or uneven surfaces.

	PROBABILITY of an incident associated with the activity described: (1=low average probability, 10= high average probability) See chart on page 1 for reference scale									
Hazard	1	2	3	4	5	6	7	8	9	10
Struck by										
Struck against										
Caught in										
Fall to Lower										
Fall to Same										
Overexertion										
Repetitive Motion										
Exposure to Harmful Substances										
Transportation Accidents										
Other										

	SEVERITY of an incident associated with the activity described: (1= low average severity, 10=high average severity) See chart on page 1 for reference scale									
Hazard	1	2	3	4	5	6	7	8	9	10
Struck by										
Struck against										
Caught in										
Fall to Lower										
Fall to Same										
Overexertion										
Repetitive Motion										
Exposure to Harmful Substances										
Transportation Accidents										
Other										

Excavation

In some situations the concrete forming process may require excavation. Excavation involves the use of appropriate equipment such as a backhoe, bulldozer, shovels, etc.

	PROBABILITY of an incident associated with the activity described: (1=low average probability, 10= high average probability) See chart on page 1 for reference scale									
Hazard	1	2	3	4	5	6	7	8	9	10
Struck by										
Struck against										
Caught in										
Fall to Lower										
Fall to Same										
Overexertion										
Repetitive Motion										
Exposure to Harmful Substances										
Transportation Accidents										
Other										

	SEVERITY of an incident associated with the activity described: (1= low average severity, 10=high average severity) See chart on page 1 for reference scale									
Hazard	1	2	3	4	5	6	7	8	9	10
Struck by										
Struck against										
Caught in										
Fall to Lower										
Fall to Same										
Overexertion										
Repetitive Motion										
Exposure to Harmful Substances										
Transportation Accidents										
Other										

OTHER

If you are aware of additional major activities that may be required to construct concrete formwork that were not mentioned above please provide a brief description and rate the probability and severity of an injury associated with each of the OIICS categories.

Activity:

Description:

	PROBABILITY of an incident associated with the activity described: (1=low average probability, 10= high average probability) See chart on page 1 for reference scale									
Hazard	1	2	3	4	5	6	7	8	9	10
Struck by										
Struck against										
Caught in										
Fall to Lower										
Fall to Same										
Overexertion										
Repetitive Motion										
Exposure to Harmful Substances										
Transportation Accidents										
Other										

	SEVERITY of an incident associated with the activity described: (1= low average severity, 10=high average severity) See chart on page 1 for reference scale									
Hazard	1	2	3	4	5	6	7	8	9	10
Struck by										
Struck against										
Caught in										
Fall to Lower										
Fall to Same										
Overexertion										
Repetitive Motion										
Exposure to Harmful Substances										
Transportation Accidents										
Other										

Appendix D – Round 2 Delphi survey of demand panel (partial)

DELPHI SURVEY – ROUND 2

Thank you for completing the Round 1 Delphi survey. We recognize that the survey required a significant time investment to complete thoughtfully. We appreciate your time and effort. This Round 2 survey continues the Delphi process for this study. The purpose of Round 2 is to provide you with the opportunity to change your response, if desired, given the median group response for each category.

This Round 2 survey is intended to be completed in approximately 10-15 minutes as you are only being asked to review your previous responses given the collective group median.

INSTRUCTIONS

For each hazard category you will see 2 values: your response from the previous survey (indicated with a highlighted box) and the group median indicated with two vertical lines (||). Please take one of the following three actions for each category:

1. **Accept the group median response by leaving the field completely unchanged.**
2. **Maintain your original response by placing an 'X' in the highlighted field*.**
3. **Indicate a new response by placing an 'X' in the appropriate field*.**

*** If your response is more than two units above or below the group median please provide a reason for your outlying response in the field provided**

The Round 1 survey provided you with the definitions of eleven construction safety incident types. If at any time you would like to review these accident categories you may find them at the following link: www.engr.orst.edu/~hallowem/Incidents.html.

We **URGE** you to review and consider the following probability and severity scales when considering your previous responses and the group median responses.

Probability Scale: Average number of worker-hours per incident									
Negligible or 0	10-100 million	1-10 million	100,000 - 1 million	10,000 - 100,000	1,000 - 10,000	100 - 1,000	10-100	1-10	<0.1-1
1	2	3	4	5	6	7	8	9	10

Severity Scale: Average loss associated with an incident (industry and hazard average)									
Negligible	Discomfort → Persistent Pain				Medical case		Lost work time		Fatality
1	2	3	4	5	6	7	8	9	10

Ascend or descend ladder

Operations that occur above or below grade typically require workers to ascend or descend ladders in order to reach the work site. Ladders may be wooden, metal or fiberglass and may vary in length substantially from one site to the next. Workers may carry materials or equipment as they ascend or descend ladders. In many cases, workers may simply climb up the formwork supports. This activity is often performed at height, below grade or on rough or uneven surfaces.

	PROBABILITY of an incident associated with the activity described: (1=low average probability, 10= high average probability) See reference scale									
Hazard	1	2	3	4	5	6	7	8	9	10
Transportation Accidents										
Caught in										
Overexertion										
Repetitive Motion										
Struck against										
Fall to Same										
Struck by										
Exposure to Harmful Substances										
Fall to Lower										
Other										

	SEVERITY of an incident associated with the activity described: (1= low average severity, 10=high average severity) See reference scale									
Hazard	1	2	3	4	5	6	7	8	9	10
Transportation Accidents										
Caught in										
Overexertion										
Repetitive Motion										
Struck against										
Fall to Same										
Struck by										
Exposure to Harmful Substances										
Fall to Lower										
Other										

Reason(s) for outlying response(s):



Appendix E – Round 3 Delphi survey of demand panel (partial)

DELPHI SURVEY – ROUND 3

Thank you for completing the Round 2 Delphi survey. We appreciate your time and effort. This Round 3 survey concludes the Delphi process for this study. The purpose of Round 3 is to provide you with a final opportunity to change your response, if desired, given the median group response AND reasons for outlying responses for each category.

This Round 3 survey is intended to be completed in approximately 15 minutes as you are only being asked to review your previous responses, group medians and reasons for outlying responses. When you have finished answering all of the questions, please email your response, in Word format, to: hallowem@onid.orst.edu .

INSTRUCTIONS

The instructions for this survey are nearly identical to that of the Round 2 survey. The only difference between this survey and the Round 2 survey is the reasons provided at the end of each page. All panelists were asked to provide reasons for responses that were more than 2 units from the median in Round 1. Please review the reasons provided by other expert panelists and consider them in your final response.

For each hazard category you will be provided with 3 pieces of information: your response from Round 2, indicated by a highlighted box, the group median from Round 2, indicated by two vertical lines (||) and several reasons for outlying responses. Please take one of the following three actions for each category:

1. **Accept the group median response by leaving the field completely unchanged.**
2. **Maintain your original response by placing an 'X' in the highlighted field.**
3. **Indicate a new response by placing an 'X' in the appropriate field.**
- 4.

The Round 1 survey provided you with the definitions of eleven construction safety incident types. If at any time you would like to review these accident categories you may find them at the following link: www.engr.orst.edu/~hallowem/Incidents.html . Also, Round 1 and Round 2 provided you with a description of each formwork activity. If at any time you would like to review these descriptions you may find them at the following link: www.engr.orst.edu/~hallowem/Formwork.html .

We **URGE** you to review and consider the following probability and severity scales when considering your previous responses and the group median responses.

Probability Scale: Average number of worker-hours per incident									
Negligible or 0	10-100 million	1-10 million	100,000 - 1 million	10,000 - 100,000	1,000 - 10,000	100 - 1,000	10-100	1-10	<0.1-1
1	2	3	4	5	6	7	8	9	10

Severity Scale: Average loss associated with an incident (industry and hazard average)									
Negligible	Discomfort → Persistent Pain				Medical case		Lost work time		Fatality
1	2	3	4	5	6	7	8	9	10

Ascend or descend ladder

	PROBABILITY of an incident associated with the activity described: (1=low average probability, 10= high average probability) See reference scale									
Hazard	1	2	3	4	5	6	7	8	9	10
Struck by										
Repetitive Motion										
Struck against										
Fall to Same										
Overexertion										
Caught in										
Fall to Lower										
Exposure to Harmful Substances										
Transportation Accidents										
Other										

	SEVERITY of an incident associated with the activity described: (1= low average severity, 10=high average severity) See reference scale									
Hazard	1	2	3	4	5	6	7	8	9	10
Struck by										
Repetitive Motion										
Struck against										
Fall to Same										
Overexertion										
Caught in										
Fall to Lower										
Exposure to Harmful Substances										
Transportation Accidents										
Other										

Reason(s) for outlying response(s):

Hazard	Recommendation	Justification
Falls to Lower Level	Increase probability score	Ladders can be very unsafe; without safety procedures assume no inspection, training, replacement schedules, etc., which increases the likelihood of incident.
Transportation Incidents	Increase severity score	I agree that the probability of transportation accidents is low, but if they occur, I think the severity is likely to be at least a medical case.

Appendix F – Round 1 Delphi survey of capacity panel (complete)

DELPHI SURVEY – ROUND 1

Thank you for completing the introductory Delphi survey. You have been qualified as an expert based upon the strict guidelines suggested in literature and several restrictions set for this study.

This Round 1 survey is intended to be completed in approximately 25-30 minutes. Subsequent surveys will require significantly less time to complete. When you have finished answering all of the questions, please email your response, in Word format, to: hallowem@onid.orst.edu .

After all Delphi participants have completed the Round 1 survey, the results will be reported to you in the form of simple statistics (e.g. median response and range). You will then be given the opportunity to change your response.

INSTRUCTIONS

This Round 1 survey begins the Delphi process for the study. Please answer all of the following questions to the best of your ability. Fields that require a response have been highlighted in yellow. Please place an “X” in the appropriate boxes.

The survey requests that you rate the ability of safety program elements to reduce the probability and severity of construction safety incidents. For your reference, safety incidents have been defined below and divided into eleven categories. The definitions are consistent with the Bureau of Labor Statistics and Occupational Safety and Health Administration’s Occupational Injury and Illness Classification system (OIICS). The detailed version of the OIICS will be provided upon request.

******VERY IMPORTANT - PLEASE READ******

For the following safety program elements please use **your experience and judgment** to rate what **you believe** the average reduction in probability and/or severity of an injury may be for each of the provided OIICS hazard codes. Please indicate the reduction in probability (i.e. average *increase* in the number of worker-hours per incident as a result of the safety program) and/or reduction in severity of the average incident. Please provide ratings **for the average contractor if no other safety program elements were implemented (i.e. individual risk reduction associated with each safety program element)**. Please provide ratings for the general construction industry and select only one probability reduction range and severity reduction value for each incident type.

Please use the following probability and severity scales for reference when rating the probability and severity for construction incidents:

Probability: Average <i>increase</i> in worker-hours per incident as a result of safety element									
<1	1-10	10-100	10-1,000	1,000-10,000	10,000-100,000	100,000-1 million	1 million-10 million	10 million to 100 million	> 100 million
1	2	3	4	5	6	7	8	9	10

Severity Scale: Average loss associated with an incident (industry and hazard average)									
Negligible	Discomfort → Persistent Pain				Medical case	Lost work time		Fatality	
1	2	3	4	5	6	7	8	9	10

When rating the ability of a safety program element to reduce the probability or severity of an incident please use the above tables for guidance. For example, if you believe a particular safety program element is capable of reducing the average probability of transportation incidents from one incident per 50 worker hours (2) to one incident per 3,000 worker hours (4) , please rate the probability mitigation as a '2' (4-2 = 2). Likewise, if you believe a safety program element may reduce the severity of falls to a lower level from significant lost work-time (9) to a high level of persistent pain (5), please rate the severity mitigation a '4' (9-5 = 4).

OIICS DEFINITIONS

Struck by object: "Struck by" applies to injuries produced by forcible contact or impact between the injured person and the source of injury when the motion producing the contact is primarily that of the source of injury rather than the person.

Includes: Struck by falling objects, struck by flying objects, and struck by swinging or slipping objects.

Struck against object: "Struck against" applies to injuries produced by forcible contact or impact between the injured person and the source of injury when the motion producing the contact is primarily that of the injured person. This major group includes: bumping into objects, stepping on objects, kicking objects, and being pushed or thrown into or against objects.

Caught in or compressed by equipment or objects: This major group includes cases in which the injury was produced when a person or part of a person was injured by being squeezed, crushed, pinched or compressed between two or more objects, or between parts of an object. **Includes:** Caught in or crushed in collapsing materials.

Fall to lower level: Applies to instances in which the injury was produced by impact between the injured person and the source of injury, the motion producing the contact being that of the person, under the following circumstances:

*-the motion of the person and the force of impact were generated by gravity, and
-the point of contact with the source of injury was lower than the surface supporting the person at the inception of the fall.*

Fall on same level: Fall on same level applies to instances in which the injury was produced by impact between the injured person and the source of injury, the motion producing the contact being that of the person, under the following circumstances:

*- the motion of the person was generated by gravity following the employee's loss of equilibrium (the person was unable to maintain an upright position) and,
- the point of contact with the source of injury was at the same level or above the surface supporting the person at the inception of the fall.*

Includes: Slips and trips.

Overexertion: Overexertion applies to cases, usually non-impact, in which the injury or illness resulted from excessive physical effort directed at an outside source of injury or illness. The physical effort may involve lifting, pulling, pushing, turning, wielding, holding, carrying, or throwing the source of injury/illness.

Repetitive motion: Repetitive motion applies when an injury or illness resulted from bodily motion which imposed stress or strain upon some part of the body due to a task's repetitive nature.

Exposure to harmful substances or environments: This category applies to cases in which the injury or illness resulted from contact with, or exposure to, a condition or substance in the environment.

Includes: contact with electric current, exposure to temperature extremes, exposure to excessive noise, etc.

Transportation accidents: This category covers events involving transportation vehicles, powered industrial vehicles, or powered mobile industrial equipment in which at least one vehicle (or mobile equipment) is in normal operation and the injury/illness was due to collision or other type of traffic accident, loss of control, or a sudden stop, start, or jolting of a vehicle regardless of the location where the event occurred.

Other: This category includes any event or exposure which is not classified or listed under any other division. Please consider the following in this category: Fires and explosions, assaults and violent acts and all other events or exposures not elsewhere categorized.

Written and comprehensive safety and health plan

A written safety and health plan involves the documentation of project-specific safety and health objectives, goals and methods for achieving success. This element should be specific to the project *and* define the safety and health objectives, goals and direction of the firm as a whole.

	PROBABILITY – Average ability of described safety program element to reduce the probability of a particular incident (1=low ability to reduce average probability, 10= high ability to reduce average probability) See chart on page 1 for reference scale									
Hazard	1	2	3	4	5	6	7	8	9	10
Struck by										
Struck against										
Caught in										
Fall to Lower										
Fall to Same										
Overexertion										
Repetitive Motion										
Exposure to Harmful Substances										
Transportation Accidents										
Other										

	SEVERITY – Average ability of described safety program element to reduce the severity of a particular incident (1 = low ability to reduce average severity, 10=high ability to reduce average severity) See chart on page 1 for reference scale									
Hazard	1	2	3	4	5	6	7	8	9	10
Struck by										
Struck against										
Caught in										
Fall to Lower										
Fall to Same										
Overexertion										
Repetitive Motion										
Exposure to Harmful Substances										
Transportation Accidents										
Other										

Upper management support and commitment

Participation and commitment of upper management involves the explicit consideration of worker safety and health as a primary goal of the firm. Upper management must regard worker safety and health as a fundamental goal and demonstrate commitment by participating in regular safety meetings, serving on committees, providing funding for other safety and health program elements. Upper management support and commitment must be demonstrated by actions and funding, not only in writing and rhetoric.

	PROBABILITY – Average ability of described safety program element to reduce the probability of a particular incident (1=low ability to reduce average probability, 10= high ability to reduce average probability) See chart on page 1 for reference scale									
Hazard	1	2	3	4	5	6	7	8	9	10
Struck by										
Struck against										
Caught in										
Fall to Lower										
Fall to Same										
Overexertion										
Repetitive Motion										
Exposure to Harmful Substances										
Transportation Accidents										
Other										

	SEVERITY – Average ability of described safety program element to reduce the severity of a particular incident (1 = low ability to reduce average severity, 10=high ability to reduce average severity) See chart on page 1 for reference scale									
Hazard	1	2	3	4	5	6	7	8	9	10
Struck by										
Struck against										
Caught in										
Fall to Lower										
Fall to Same										
Overexertion										
Repetitive Motion										
Exposure to Harmful Substances										
Transportation Accidents										
Other										

Job hazard analyses and hazard communication

Contractors may begin a job hazard analysis by reviewing the activities associated with a construction process and identifying potential hazardous exposures that may lead to an injury. Other sources such as OSHA logs, violation reports, accident investigation reports, interviews with laborers or simply intuition may be used to identify hazards. A critical component of this safety program element is that once hazards are identified, they are communicated to the workers.

	PROBABILITY – Average ability of described safety program element to reduce the probability of a particular incident (1=low ability to reduce average probability, 10= high ability to reduce average probability) See chart on page 1 for reference scale									
Hazard	1	2	3	4	5	6	7	8	9	10
Struck by										
Struck against										
Caught in										
Fall to Lower										
Fall to Same										
Overexertion										
Repetitive Motion										
Exposure to Harmful Substances										
Transportation Accidents										
Other										

	SEVERITY – Average ability of described safety program element to reduce the severity of a particular incident (1 = low ability to reduce average severity, 10=high ability to reduce average severity) See chart on page 1 for reference scale									
Hazard	1	2	3	4	5	6	7	8	9	10
Struck by										
Struck against										
Caught in										
Fall to Lower										
Fall to Same										
Overexertion										
Repetitive Motion										
Exposure to Harmful Substances										
Transportation Accidents										
Other										

Safety and health orientation and training

The orientation of all new hires may be the most important safety training. Even skilled and experienced workers should be provided with a firm-specific safety and health orientation and training. Such training and orientation informs new hires of company safety goals, policies, programs, resources, etc. This element involves the firm-specific, but not necessarily project-specific, orientation and training of all new hires (or existing employees if a safety and health program is new to the firm).

	PROBABILITY – Average ability of described safety program element to reduce the probability of a particular incident (1=low ability to reduce average probability, 10= high ability to reduce average probability) See chart on page 1 for reference scale									
Hazard	1	2	3	4	5	6	7	8	9	10
Struck by										
Struck against										
Caught in										
Fall to Lower										
Fall to Same										
Overexertion										
Repetitive Motion										
Exposure to Harmful Substances										
Transportation Accidents										
Other										

	SEVERITY – Average ability of described safety program element to reduce the severity of a particular incident (1 = low ability to reduce average severity, 10=high ability to reduce average severity) See chart on page 1 for reference scale									
Hazard	1	2	3	4	5	6	7	8	9	10
Struck by										
Struck against										
Caught in										
Fall to Lower										
Fall to Same										
Overexertion										
Repetitive Motion										
Exposure to Harmful Substances										
Transportation Accidents										
Other										

Frequent worksite inspections

Worksite inspections may be performed by a contractor's safety manager, safety committee, representative of the contractor's insurance provider or by an OSHA consultant. The purpose of a safety and health inspection is to identify uncontrolled hazardous exposures to workers, violations of safety standards or OSHA regulations or the unsafe behavior of workers. Inspections must occur on a regular basis.

	PROBABILITY – Average ability of described safety program element to reduce the probability of a particular incident (1=low ability to reduce average probability, 10= high ability to reduce average probability) See chart on page 1 for reference scale									
Hazard	1	2	3	4	5	6	7	8	9	10
Struck by										
Struck against										
Caught in										
Fall to Lower										
Fall to Same										
Overexertion										
Repetitive Motion										
Exposure to Harmful Substances										
Transportation Accidents										
Other										

	SEVERITY – Average ability of described safety program element to reduce the severity of a particular incident (1 = low ability to reduce average severity, 10=high ability to reduce average severity) See chart on page 1 for reference scale									
Hazard	1	2	3	4	5	6	7	8	9	10
Struck by										
Struck against										
Caught in										
Fall to Lower										
Fall to Same										
Overexertion										
Repetitive Motion										
Exposure to Harmful Substances										
Transportation Accidents										
Other										

Emergency response planning

This safety program element involves the creation of plan in the case of a serious incident such as a fatality or an incident involving multiple serious injuries. Planning for emergencies can define the difference between an accident and a catastrophic event. Such a plan may be required by the Owner or insurance carrier.

	PROBABILITY – Average ability of described safety program element to reduce the probability of a particular incident (1=low ability to reduce average probability, 10= high ability to reduce average probability) See chart on page 1 for reference scale									
Hazard	1	2	3	4	5	6	7	8	9	10
Struck by										
Struck against										
Caught in										
Fall to Lower										
Fall to Same										
Overexertion										
Repetitive Motion										
Exposure to Harmful Substances										
Transportation Accidents										
Other										

	SEVERITY – Average ability of described safety program element to reduce the severity of a particular incident (1 = low ability to reduce average severity, 10=high ability to reduce average severity) See chart on page 1 for reference scale									
Hazard	1	2	3	4	5	6	7	8	9	10
Struck by										
Struck against										
Caught in										
Fall to Lower										
Fall to Same										
Overexertion										
Repetitive Motion										
Exposure to Harmful Substances										
Transportation Accidents										
Other										

Record keeping and accident analyses

This safety program element involves documenting and reporting the specifics of all accidents including information such as time, location, work-site conditions or cause. The element also includes the analyses of accident data to reveal trends, points of weakness in the firm's safety program, or poor execution of program elements.

	PROBABILITY – Average ability of described safety program element to reduce the probability of a particular incident (1=low ability to reduce average probability, 10= high ability to reduce average probability) See chart on page 1 for reference scale									
Hazard	1	2	3	4	5	6	7	8	9	10
Struck by										
Struck against										
Caught in										
Fall to Lower										
Fall to Same										
Overexertion										
Repetitive Motion										
Exposure to Harmful Substances										
Transportation Accidents										
Other										

	SEVERITY – Average ability of described safety program element to reduce the severity of a particular incident (1 = low ability to reduce average severity, 10=high ability to reduce average severity) See chart on page 1 for reference scale									
Hazard	1	2	3	4	5	6	7	8	9	10
Struck by										
Struck against										
Caught in										
Fall to Lower										
Fall to Same										
Overexertion										
Repetitive Motion										
Exposure to Harmful Substances										
Transportation Accidents										
Other										

Project-specific training and regular safety meetings

This element involves the establishment and communication of project-specific safety goals, plans and policies before the start of the project. Safety training may include reviewing project-specific or task-specific hazard communication, methods of safe work behavior, company policies, safety and health goals, etc. This element also involves the regular safety meetings such as toolbox talks to reinforce and refresh safety and health training.

	PROBABILITY – Average ability of described safety program element to reduce the probability of a particular incident (1=low ability to reduce average probability, 10= high ability to reduce average probability) See chart on page 1 for reference scale									
Hazard	1	2	3	4	5	6	7	8	9	10
Struck by										
Struck against										
Caught in										
Fall to Lower										
Fall to Same										
Overexertion										
Repetitive Motion										
Exposure to Harmful Substances										
Transportation Accidents										
Other										

	SEVERITY – Average ability of described safety program element to reduce the severity of a particular incident (1 = low ability to reduce average severity, 10=high ability to reduce average severity) See chart on page 1 for reference scale									
Hazard	1	2	3	4	5	6	7	8	9	10
Struck by										
Struck against										
Caught in										
Fall to Lower										
Fall to Same										
Overexertion										
Repetitive Motion										
Exposure to Harmful Substances										
Transportation Accidents										
Other										

Safety and health committees

A committee made up of supervisors, laborers, representatives of key subcontractors, owner representatives, OSHA consultants, etc. may be formed with the sole purpose of addressing safety and health on the worksite. Such a committee must hold regular (e.g. weekly or bi-weekly) meetings to address safety and health by performing inspections, discussing job hazard analyses or directing safety meetings and training.

	PROBABILITY – Average ability of described safety program element to reduce the probability of a particular incident (1=low ability to reduce average probability, 10= high ability to reduce average probability) See chart on page 1 for reference scale									
Hazard	1	2	3	4	5	6	7	8	9	10
Struck by										
Struck against										
Caught in										
Fall to Lower										
Fall to Same										
Overexertion										
Repetitive Motion										
Exposure to Harmful Substances										
Transportation Accidents										
Other										

	SEVERITY – Average ability of described safety program element to reduce the severity of a particular incident (1 = low ability to reduce average severity, 10=high ability to reduce average severity) See chart on page 1 for reference scale									
Hazard	1	2	3	4	5	6	7	8	9	10
Struck by										
Struck against										
Caught in										
Fall to Lower										
Fall to Same										
Overexertion										
Repetitive Motion										
Exposure to Harmful Substances										
Transportation Accidents										
Other										

Substance abuse programs

This safety program element targets the identification and prevention of substance abuse. Testing is a crucial component of this safety program element. Methods of testing and consequences of failure may differ from one firm to another. However, repeated violations are typically grounds for dismissal of the employee. Testing may occur on a regular or random basis and always for employees involved with an incident that involves a medical case or lost work-time injury or fatality.

	PROBABILITY – Average ability of described safety program element to reduce the probability of a particular incident (1=low ability to reduce average probability, 10= high ability to reduce average probability) See chart on page 1 for reference scale									
Hazard	1	2	3	4	5	6	7	8	9	10
Struck by										
Struck against										
Caught in										
Fall to Lower										
Fall to Same										
Overexertion										
Repetitive Motion										
Exposure to Harmful Substances										
Transportation Accidents										
Other										

	SEVERITY – Average ability of described safety program element to reduce the severity of a particular incident (1 = low ability to reduce average severity, 10=high ability to reduce average severity) See chart on page 1 for reference scale									
Hazard	1	2	3	4	5	6	7	8	9	10
Struck by										
Struck against										
Caught in										
Fall to Lower										
Fall to Same										
Overexertion										
Repetitive Motion										
Exposure to Harmful Substances										
Transportation Accidents										
Other										

Safety manager on site

Simply, this safety program element involves the employment of a safety and health professional (i.e. an individual with construction safety and health experience and/or education). This individual's primary responsibility is to perform and direct safety and health program elements (e.g. accident investigation, inspections, orientation) and to serve as a safety and health resource for employees.

	PROBABILITY – Average ability of described safety program element to reduce the probability of a particular incident (1=low ability to reduce average probability, 10= high ability to reduce average probability) See chart on page 1 for reference scale									
Hazard	1	2	3	4	5	6	7	8	9	10
Struck by										
Struck against										
Caught in										
Fall to Lower										
Fall to Same										
Overexertion										
Repetitive Motion										
Exposure to Harmful Substances										
Transportation Accidents										
Other										

	SEVERITY – Average ability of described safety program element to reduce the severity of a particular incident (1 = low ability to reduce average severity, 10=high ability to reduce average severity) See chart on page 1 for reference scale									
Hazard	1	2	3	4	5	6	7	8	9	10
Struck by										
Struck against										
Caught in										
Fall to Lower										
Fall to Same										
Overexertion										
Repetitive Motion										
Exposure to Harmful Substances										
Transportation Accidents										
Other										

Subcontractor selection and management

This element involves the consideration of safety and health performance during the selection of subcontractors. That is, only subcontractors with demonstrated ability to work safely should be considered during the bidding or negotiating process. Once a contract is awarded, the subcontractor must be required to comply with the minimum requirements of the general contractor's safety and health program.

	PROBABILITY – Average ability of described safety program element to reduce the probability of a particular incident (1=low ability to reduce average probability, 10= high ability to reduce average probability) See chart on page 1 for reference scale									
Hazard	1	2	3	4	5	6	7	8	9	10
Struck by										
Struck against										
Caught in										
Fall to Lower										
Fall to Same										
Overexertion										
Repetitive Motion										
Exposure to Harmful Substances										
Transportation Accidents										
Other										

	SEVERITY – Average ability of described safety program element to reduce the severity of a particular incident (1 = low ability to reduce average severity, 10=high ability to reduce average severity) See chart on page 1 for reference scale									
Hazard	1	2	3	4	5	6	7	8	9	10
Struck by										
Struck against										
Caught in										
Fall to Lower										
Fall to Same										
Overexertion										
Repetitive Motion										
Exposure to Harmful Substances										
Transportation Accidents										
Other										

Employee involvement and evaluation in safety management and planning

Employee involvement and evaluation is a means of including all employees in the formulation and execution of other safety program elements. Involvement in safety and health activities may include activities such as performing job hazard analyses, participating in toolbox talks or performing inspections. Evaluation of employees' safety performance involves considering safety metrics during regular employee performance evaluations. This may include the consideration of incident frequency, inspection results and consideration of near misses.

	PROBABILITY – Average ability of described safety program element to reduce the probability of a particular incident (1=low ability to reduce average probability, 10= high ability to reduce average probability) See chart on page 1 for reference scale									
Hazard	1	2	3	4	5	6	7	8	9	10
Struck by										
Struck against										
Caught in										
Fall to Lower										
Fall to Same										
Overexertion										
Repetitive Motion										
Exposure to Harmful Substances										
Transportation Accidents										
Other										

	SEVERITY – Average ability of described safety program element to reduce the severity of a particular incident (1 = low ability to reduce average severity, 10=high ability to reduce average severity) See chart on page 1 for reference scale									
Hazard	1	2	3	4	5	6	7	8	9	10
Struck by										
Struck against										
Caught in										
Fall to Lower										
Fall to Same										
Overexertion										
Repetitive Motion										
Exposure to Harmful Substances										
Transportation Accidents										
Other										

Appendix G – Round 2 Delphi survey of capacity panel (partial)

DELPHI SURVEY - ROUND 2

Thank you for completing the Round 1 Delphi survey. We recognize that the survey required a significant time investment to complete thoughtfully. We appreciate your time and effort. This Round 2 survey continues the Delphi process for this study. The purpose of Round 2 is to provide you with the opportunity to change your response, if desired, given the median group response for each category.

This Round 2 survey is intended to be completed in approximately 10-15 minutes as you are only being asked to review your previous responses given the collective group median. When you have finished answering all of the questions, please email your response, in Word format, to: hallowem@onid.orst.edu.

INSTRUCTIONS

For each hazard category you will see 2 values: your response from the Round 1 survey (indicated with a highlighted box), and the group median from the Round 1 survey indicated with two vertical lines (||). Please take one of the following three actions for each category:

5. **Accept the group median response by leaving the field completely unchanged.**
6. **Maintain your original response by placing an 'X' in the highlighted field*.**
7. **Indicate a new response by placing an 'X' in the appropriate field*.**

*** If your response is more than two units above or below the group median please provide a reason for your outlying response in the field provided.**

The Round 1 survey provided you with the definitions of eleven construction safety incident types. If at any time you would like to review these accident categories you may find them at the following link: www.engr.orst.edu/~hallowem/Incidents.html.

We **URGE** you to review and consider the following probability and severity scales when considering your previous responses and the group median responses. We have reason to believe that some respondents did not fully consider the scales during the first round thereby resulting in an overestimate of the ability of safety program elements to mitigate risk. Please review the following scale and consider this scale in your responses. Detailed directions for using the scales may be found at: www.engr.orst.edu/~hallowem/DelphiScale.html

Substance abuse programs

This safety program element targets the identification and prevention of substance abuse. Testing is a crucial component of this safety program element. Methods of testing and consequences of failure may differ from one firm to another. However, repeated violations are typically grounds for dismissal of the employee. Testing may occur on a regular or random basis and always for employees involved with an incident that involves a medical case or lost work-time injury or fatality.

	PROBABILITY – Average ability of described safety program element to reduce the probability of a particular incident (1=low ability to reduce average probability, 10= high ability to reduce average probability) See reference scale									
Hazard	1	2	3	4	5	6	7	8	9	10
Struck against										
Fall to Lower										
Fall to Same										
Struck by										
Transportation Accidents										
Overexertion										
Repetitive Motion										
Caught in										
Exposure to Harmful Substances										
Other										

	SEVERITY – Average ability of described safety program element to reduce the severity of a particular incident (1 = low ability to reduce average severity, 10=high ability to reduce average severity) See reference scale									
Hazard	1	2	3	4	5	6	7	8	9	10
Struck against										
Fall to Lower										
Fall to Same										
Struck by										
Transportation Accidents										
Overexertion										
Repetitive Motion										
Caught in										
Exposure to Harmful Substances										
Other										

Reason(s) for outlying response(s):

[Redacted area]

Appendix H – Round 3 Delphi survey of capacity panel (partial)

DELPHI SURVEY – ROUND 3

Thank you for completing the Round 2 Delphi survey. We appreciate your time and effort. This Round 3 survey concludes the Delphi process for this study. The purpose of Round 3 is to provide you with a final opportunity to change your response, if desired, given the median group response AND reasons for outlying responses for each category.

This Round 3 survey is intended to be completed in approximately 15 minutes as you are only being asked to review your previous responses, group medians and reasons for outlying responses. When you have finished answering all of the questions, please email your response, in Word format, to: hallowem@onid.orst.edu .

INSTRUCTIONS

The instructions for this survey are nearly identical to that of the Round 2 survey. The only difference between this survey and the Round 2 survey is the reasons provided at the end of each page. All panelists were asked to provide reasons for responses that were more than 2 units from the median in Round 1. Please review the reasons provided by other expert panelists and consider them in your final response.

For each hazard category you will be provided with 3 pieces of information: your response from Round 2, indicated by a highlighted box, the group median from Round 2, indicated by two vertical lines (||) and several reasons for outlying responses. Please take one of the following three actions for each category:

1. **Accept the group median response by leaving the field completely unchanged.**
2. **Maintain your original response by placing an 'X' in the highlighted field.**
3. **Indicate a new response by placing an 'X' in the appropriate field.**

The Round 1 survey provided you with the definitions of eleven construction safety incident types. If at any time you would like to review these accident categories you may find them at the following link: www.engr.orst.edu/~hallowem/Incidents.html . Also, Round 1 and Round 2 provided you with a description of each safety program element. If at any time you would like to review these descriptions you may find them at the following link: www.engr.orst.edu/~hallowem/Elements.html .

We **URGE** you to review and consider the following probability and severity scales when considering your previous responses and the group median responses. Detailed directions for using the scales may be found at: www.engr.orst.edu/~hallowem/DelphiScale.html

Substance abuse programs

	PROBABILITY – Average ability of described safety program element to reduce the probability of a particular incident (1=low ability to reduce average probability, 10= high ability to reduce average probability) See reference scale									
Hazard	1	2	3	4	5	6	7	8	9	10
Struck against										
Fall to Lower										
Fall to Same										
Struck by										
Transportation Accidents										
Overexertion										
Repetitive Motion										
Caught in										
Exposure to Harmful Substances										
Other										

	SEVERITY – Average ability of described safety program element to reduce the severity of a particular incident (1 = low ability to reduce average severity, 10=high ability to reduce average severity) See reference scale									
Hazard	1	2	3	4	5	6	7	8	9	10
Struck against										
Fall to Lower										
Fall to Same										
Struck by										
Transportation Accidents										
Overexertion										
Repetitive Motion										
Caught in										
Exposure to Harmful Substances										
Other										

Reason(s) for outlying response(s):

Hazard	Recommendation	Justification
General	Increase probability and severity reduction scores	THE PRESENCE AND USE OF HEAVY AND LIGHT EQUIPMENT ADDS MORE HAZARDS TO AN ALREADY INHERENTLY DANGEROUS WORK ENVIRONMENT. PUBLICIZED DRUG POLICY AND RANDOM TESTING WILL REDUCE HIRING OF ADDICTS AND USE OF DRUGS.

Appendix I: Delphi Panel Round 1 Survey (Validation)

DELPHI SURVEY – ROUND 1

Thank you for completing the introductory Delphi survey. You have been qualified as an expert to participate in this study.

This Round 1 survey is intended to be completed in approximately 15 minutes. Subsequent surveys will require less time to complete. When you have finished answering all of the questions, please email your response, in Word format, to hallowem@onid.orst.edu. After all Delphi participants have completed the Round 1 survey, the results will be reported to you in the form of simple statistics (e.g. median response and range). You will then be given the opportunity to change your response.

PART I: INSTRUCTIONS

For part I, below are 13 activities that characterize the process of constructing concrete formwork. Please read these activities carefully. Based on the list of activities you will be asked to rate the effectiveness of common safety program elements. That is, you will be asked to rate the ability of common safety program elements to mitigate risks posed by the activities required to construct concrete formwork. Once you have rated the various safety program elements you will be asked to identify which elements would be required to mitigate the risk (i.e. the level of safety protection that is sufficient for mitigating risks associated with constructing formwork).

Please answer all of the questions to the best of your ability. Fields that require a response have been highlighted in yellow. The activities required to form concrete are as follows:

1. Form lubrication and preparation

Spraying form oil; spraying curing compound; setting and wetting curing blankets and setting expansion materials.

2. Nail/screw/drill form components or other materials

Nailing or screwing form components or materials may involve the use of a hammer (typically larger than 20 oz.), nail gun, electric screwdriver, impact wrench, staple gun or other basic equipment. The worker may be required to repeat this activity for an extended period of time at certain stages of the formwork process. When gang forms are used special forming hardware may be used. This activity is often performed at height, below grade or on rough or uneven surfaces.

3. Transport materials and equipment without motorized assistance

Transporting equipment and materials may include carrying items of varying weights such as 2x4's, plywood, form panels, ties, cat heads, adjustable pipe braces, etc. from one

location to another. Workers may use a wheelbarrow, bucket with handles or may carry materials by hand. This activity is often performed at height, below grade or on rough or uneven surfaces.

4. Cut materials using circular or table saw

During most formwork operations materials such as 2x4's, plywood or aluminum must be cut to size. Typically, equipment such as a circulating saw, reciprocating or table saw is used to cut materials. Other equipment may be used in some cases. This activity required the worker to operate such equipment and guide materials during cutting/ripping. This activity is often performed at height, below grade or on rough or uneven surfaces.

5. Inspect forms and construction planning

During construction workers and crew leaders often take time to inspect their work and plan for subsequent operations. Formwork must be inspected by a competent person prior to placing concrete. This activity is often performed at height, below grade or on rough or uneven surfaces.

6. Hold materials or components in place (static lift)

The process of forming concrete may require workers to temporarily support a portion of the concrete form while other workers connect materials or components. This activity involves a static lift and may be accompanied by lifting/lowering. This activity may occur when work teams connect panels to stakes/columns, install bracing, level or plumb forms, etc. Typically, the worker holding the materials or components must wait for other workers to complete tasks before relief. This activity is often performed at height, below grade or on rough or uneven surfaces.

7. Excavation

In some situations the concrete forming process may require excavation. Excavation involves the use of appropriate equipment such as a backhoe, bulldozer, shovels, etc.

8. Accept/load/connect materials or forms from crane

When a crane is used to transport materials or form components workers must accept the materials from the crane and/or load the crane with excess materials or waste. Workers must direct the crane operator as the material is lifted/lowered and may be required to physically accept the load. This activity is most likely to occur when formwork operations occur above or below grade and the use of scissor lifts or worker transport is unrealistic. A combination of aerial lifts and cranes may be used in this activity. This activity is often performed at height, below grade or on rough or uneven surfaces.

9. Hammer using sledgehammer or other equipment

This activity involves hammering stakes or other components into the soil or other material. This activity is different from nailing components and materials because heavier tools such as a sledgehammer are used to drive objects. In other words, hammering in this

category refers to an activity that requires fewer strikes of larger force than nailing. This activity is often performed at height, below grade or on rough or uneven surfaces.

10. Ascend or descend ladder

Operations that occur above or below grade typically require workers to ascend or descend ladders in order to reach the work site. Ladders may be wooden, metal or fiberglass and may vary in length substantially from one site to the next. Workers may be carry materials or equipment as they ascend or descend ladders. In many cases, workers may simply climb up the formwork supports. This activity is often performed at height, below grade or on rough or uneven surfaces.

11. Plumb and/or level forms using body weight, pry bar or other equipment

Leveling and plumbing forms is a common activity for nearly all formwork operations and involves using body weight, pry bars or other equipment to shift and adjust the formwork. This activity may be executed by a single individual or multiple individuals. A screw jack may be used for this activity and some workers may be surveying or using hand levels, lasers or plumb bobs to ensure proper placement. This activity is often performed at height, below grade or on rough or uneven surfaces.

12. Lift or lower materials, form components or equipment

Perhaps one of the most common activities for any construction process, lifting and lowering involves unassisted vertical transport of construction materials, formwork components or equipment. The process of forming concrete may require that workers lift materials from foot-level to a higher grade or from foot-level to a lower grade. In many cases workers will pass materials, equipments or components to co-workers located at the higher or lower grades without the assistance of pulleys, cranes or other mechanical devices. This activity is often performed at height, below grade or on rough or uneven surfaces.

13. Transport materials using construction vehicle or other motorized assistance

Materials may be transported by vehicles such as trucks, skid steers, forklifts, cranes or scissor lifts when the equipment is readily available or when the site is relatively large and formwork sites, mills and material/equipment storage is spread. Motorized transport is typically used when it is time-prohibitive or otherwise unrealistic for workers to transport materials by hand. This activity primarily involves operating transportation equipment through the construction site. This activity may be performed at height, below grade or on rough or uneven surfaces.

SAFETY PROGRAM ELEMENTS

Based on the formwork activities above, please rate the effectiveness of the following safety program elements to mitigate the safety risks associated with the activities using a scale of 1 to 10 where 1 represents an ineffective safety program element and 10 represents a safety program element that is absolutely critical. Please distinguish among the safety program elements if you believe there is a difference in their ability to mitigate

the risks associated with the formwork activities described above. A description of each of the safety program elements can be found at the following link: www.engr.orst.edu/~hallowem/elements.html

Safety Program Element	Effectiveness Rating (1-10)
Employee involvement and evaluation in safety management and planning	
Record keeping and accident analyses	
Written and comprehensive safety and health plan	
Emergency response planning	
Subcontractor selection and management	
Safety and health orientation and training	
Safety manager on site	
Frequent worksite inspections	
Project-specific training and regular safety meetings	
Substance abuse programs	
Safety and health committees	
Job hazard analyses and hazard communication	
Upper management support and commitment	

Please indicate which of the following safety program elements are necessary to mitigate the risk associated with the formwork activities listed above. Please place an 'X' in the yellow box corresponding only to the elements that are critical. In other words, please indicate the minimum level of safety protection necessary for workers engaged in the above 13 activities.

Safety Program Element	Critical Elements
Employee involvement and evaluation in safety management and planning	
Record keeping and accident analyses	
Written and comprehensive safety and health plan	
Emergency response planning	
Subcontractor selection and management	
Safety and health orientation and training	
Safety manager on site	
Frequent worksite inspections	
Project-specific training and regular safety meetings	
Substance abuse programs	
Safety and health committees	
Job hazard analyses and hazard communication	
Upper management support and commitment	

Appendix J – Risk perception survey

Site: _____
Time Period: _____
(Note: the time period must be the same for all forms)
Contractor ID: _____

For the severity levels below, please indicate the amount of time that you would expect between incidents of the given severity types provided that the **CONDITIONS AND NUMBER OF WORKERS ON THE CREW WERE THE SAME AS THE TIME PERIOD LISTED**. For example, if you were to continue working on this same project (same activities, project size, location, crew, etc.) how long would it take, on average, for an injury where someone had to seek minor first aid to occur? Please complete this with formwork in mind.

Severity	Description	Expected duration between incidents (i.e. 1 incident per every _____)
Near miss	Incident that does not result in harm to a worker	
Negligible	Incident that results in extremely minor (mostly unnoticeable) injury	
Temporary discomfort	Incident that resulted in temporary discomfort (one workday or less) but does not prevent the worker from functioning normally	
Persistent discomfort	Incident that resulted in persistent discomfort (more than 1 workday) but does not prevent the worker from functioning normally	
Temporary pain	Incident that resulted in temporary pain (one workday or less) but does not prevent the worker from functioning normally	
Persistent Pain	Incident that resulted in persistent pain (more than 1 workday) but does not prevent the worker from functioning normally	
Minor first aid	Incident that required minor first aid treatment. The worker may not finish the workday after the incident but returns to work w/in 1 day.	
Major first aid	Incident that required major medical treatment (worker returned to regular work w/in 1 day)	
Lost work-time	Incident that resulted in lost work time (worker could not return to regular work w/in 1 day)	
Medical Case	Incident that resulted in significant medical treatment and resulted in lost work time (worker could not return to regular work w/in 1 day)	

Permanent Disablement	Incident that results in an injury that causes permanent disablement	
Fatality	Incident that results in the death of a worker	

Appendix K – Incident data form

Site: _____
Time Period: _____
(Note: the time period must be the same for all forms)
Contractor ID: _____

Severity	Number of incidents	# of workers affected	Brief incident description(s)
Near miss			
Incident that resulted in negligible injury			
Incident that resulted in temporary discomfort			
Incident that resulted in persistent discomfort			
Incident that resulted in temporary pain			
Incident that resulted in persistent pain			
Incident that required minor medical treatment (worker returned to work w/in 1 day)			
Incident that required major medical treatment (worker returned to regular work w/in 1 day)			
Incident that resulted in lost work time (worker could not return to regular w/in 1 day)			
Incident that resulted in significant medical treatment and resulted in lost work time (worker could not return to regular work w/in 1 day)			
Worker was permanently disabled			
Fatality			

Appendix L – Expected activities form

SUMMARY OF CONSTRUCTION FORMWORK ACTIVITIES

Site: _____
Time Period: _____
(Note: the time period must be the same for all forms)
Contractor ID: _____

Activity	Was this activity performed in the given time period?		Estimated number of worker-hours		<u>OR</u> Est. worker-hours
	Yes	No	# of workers	# of hours (per worker)	
	Transport materials and equipment without motorized assistance	<input type="checkbox"/>	<input type="checkbox"/>		
Transport materials using construction vehicle or other motorized assistance	<input type="checkbox"/>	<input type="checkbox"/>			
Lift or lower materials, form components or equipment	<input type="checkbox"/>	<input type="checkbox"/>			
Hold materials or components in place (static lift)	<input type="checkbox"/>	<input type="checkbox"/>			
Accept/load/connect materials or forms from crane	<input type="checkbox"/>	<input type="checkbox"/>			
Cut materials using circular or table saw	<input type="checkbox"/>	<input type="checkbox"/>			
Nail/screw/drill form components or other materials	<input type="checkbox"/>	<input type="checkbox"/>			
Hammer using sledgehammer or other equipment	<input type="checkbox"/>	<input type="checkbox"/>			
Plumb and/or level forms using body weight, pry bar or other equipment	<input type="checkbox"/>	<input type="checkbox"/>			
Ascend or descend ladder	<input type="checkbox"/>	<input type="checkbox"/>			
Inspect forms and construction planning	<input type="checkbox"/>	<input type="checkbox"/>			
Excavation	<input type="checkbox"/>	<input type="checkbox"/>			
Form lubrication and preparation	<input type="checkbox"/>	<input type="checkbox"/>			

Appendix M – Survey of safety program elements implemented

SUMMARY OF SAFETY PROGRAM ELEMENTS

Site: _____
Time Period: _____

(Note: the time period must be the same for all forms)

Contractor ID: _____

Element	Implementation			Description of scope/intensity of implementation
	Project-wide	Specifically for formwork	Imp. during time period?	
Written and comprehensive safety and health plan	<input type="checkbox"/>	<input type="checkbox"/>	<input type="checkbox"/>	
Upper management support and commitment	<input type="checkbox"/>	<input type="checkbox"/>	<input type="checkbox"/>	
Job hazard analyses and hazard communication	<input type="checkbox"/>	<input type="checkbox"/>	<input type="checkbox"/>	
Safety and health orientation and training	<input type="checkbox"/>	<input type="checkbox"/>	<input type="checkbox"/>	
Frequent worksite inspections	<input type="checkbox"/>	<input type="checkbox"/>	<input type="checkbox"/>	
Emergency response planning	<input type="checkbox"/>	<input type="checkbox"/>	<input type="checkbox"/>	
Record keeping and accident analyses	<input type="checkbox"/>	<input type="checkbox"/>	<input type="checkbox"/>	
Project-specific training and regular safety meetings	<input type="checkbox"/>	<input type="checkbox"/>	<input type="checkbox"/>	
Safety and health committees	<input type="checkbox"/>	<input type="checkbox"/>	<input type="checkbox"/>	
Substance abuse programs	<input type="checkbox"/>	<input type="checkbox"/>	<input type="checkbox"/>	
Safety manager on site	<input type="checkbox"/>	<input type="checkbox"/>	<input type="checkbox"/>	
Subcontractor selection and management	<input type="checkbox"/>	<input type="checkbox"/>	<input type="checkbox"/>	
Employee involvement and evaluation in safety management and planning	<input type="checkbox"/>	<input type="checkbox"/>	<input type="checkbox"/>	

